

A	B	C	D	
1	S78-008	596	177	2/2
2	S78-023	538	596	2/2
3	S78-125	799	387	1/2
4	S78-126	799	387	1/2
5	S78-201	600	387	1/2
6	S78-301	567	387	1/2
7	S78-305	567	385	1/2
8	S78-401	567	60	1/2
9	S78-501	600	33	1/2
10	S78-906	529	348	1/2
11	S78-914	750	594	2/2
12	ZS1-529	350	120	1/2
13	ZS1-530	350	120	1/2
14	ZS1-5522	518	120	1/2

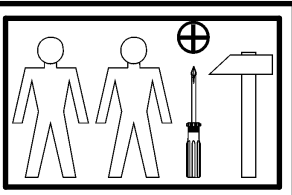

2x a44	2x b33	1x c239/1	1x c239/2	4x φ5x17 mm d1	4x φ5x9 mm e19	4x φ6,3x13 mm e2	6x φ6x13 mm e3	14x φ8x30 mm f1
4x φ6,5x40 mm f25	3x M4x16 mm j83	4x k1	30x l1	4x φ3,5x15 mm p51	10x φ1,5x12mm #16 r1	4x φ12x10,5mm #12 r15	14x r16	2x ø16 s2
1x 350 mm w45\CL	1x 350 mm w45\CR	1x 350 mm w45\DL	1x 350 mm w45\DR	1x n26\1	1x φ3,5x16 mm p38			

1

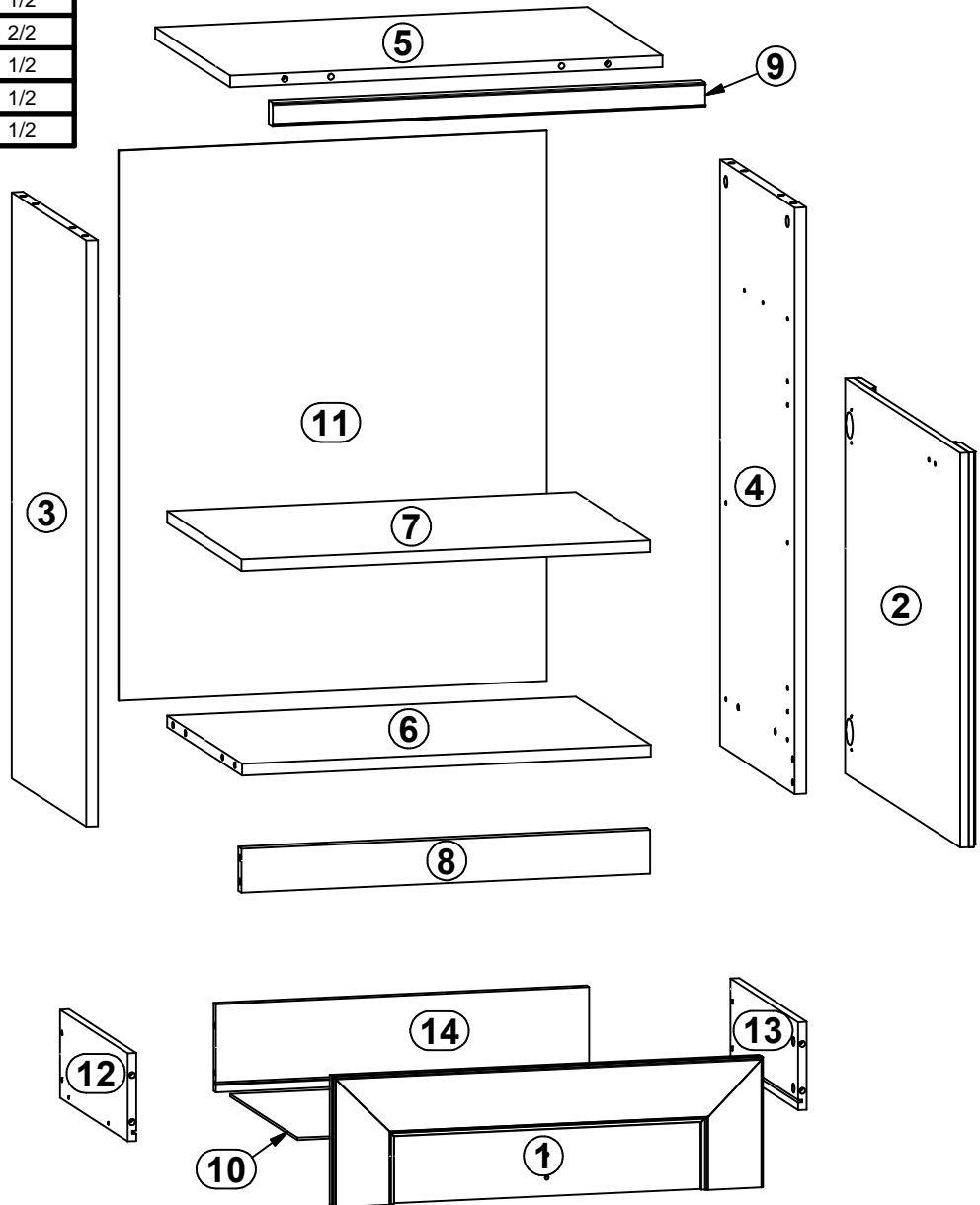
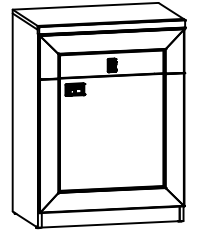
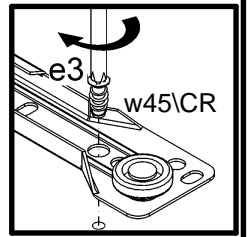
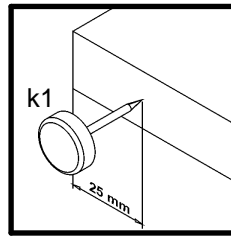
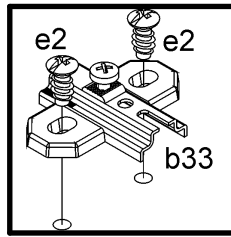
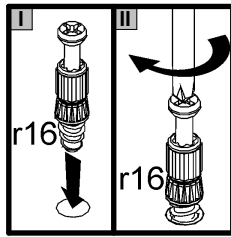
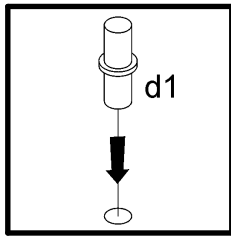
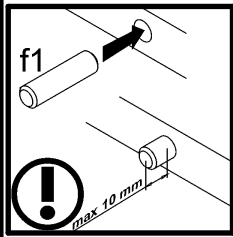
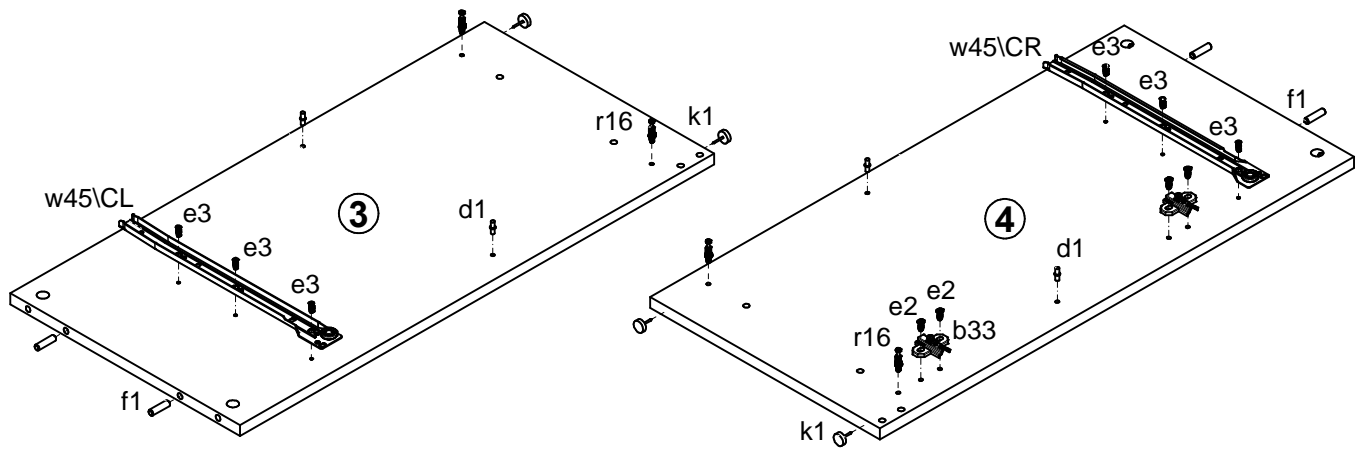

2

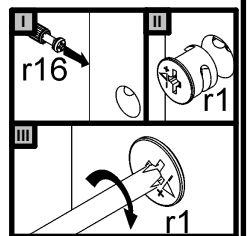
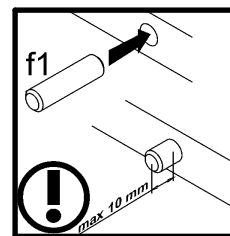
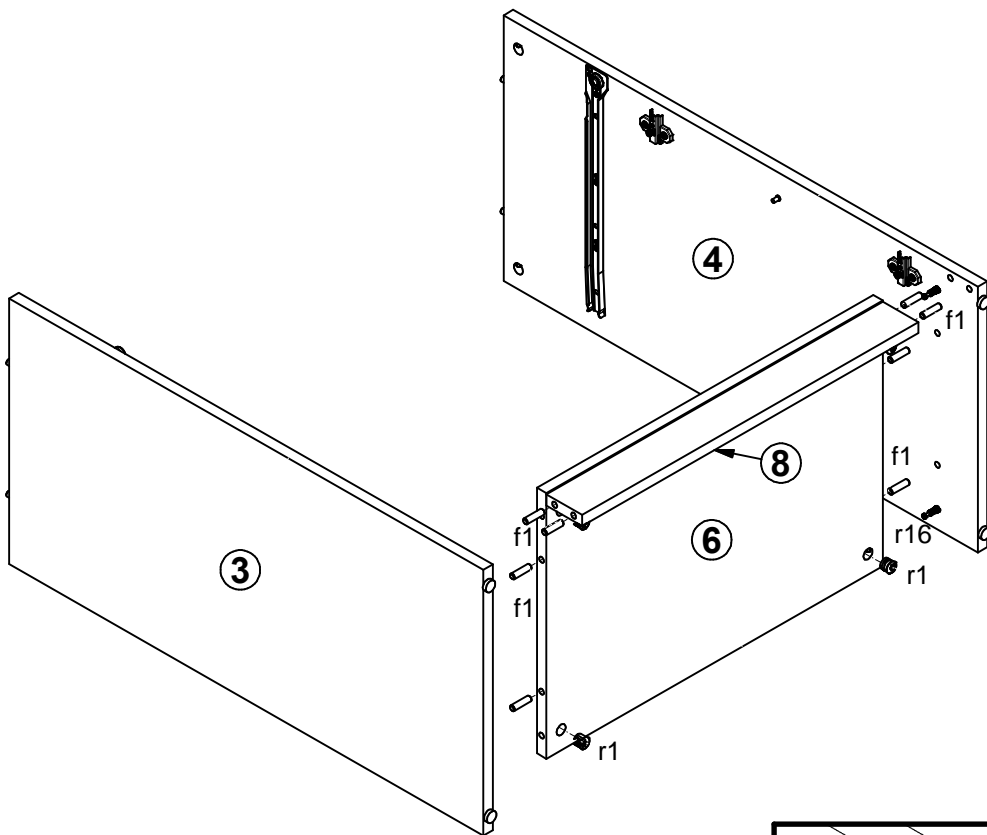

3

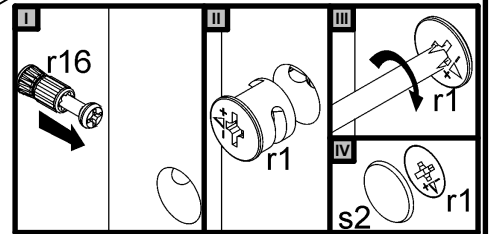
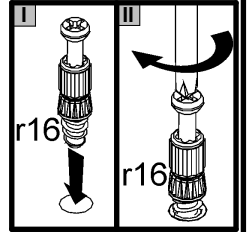
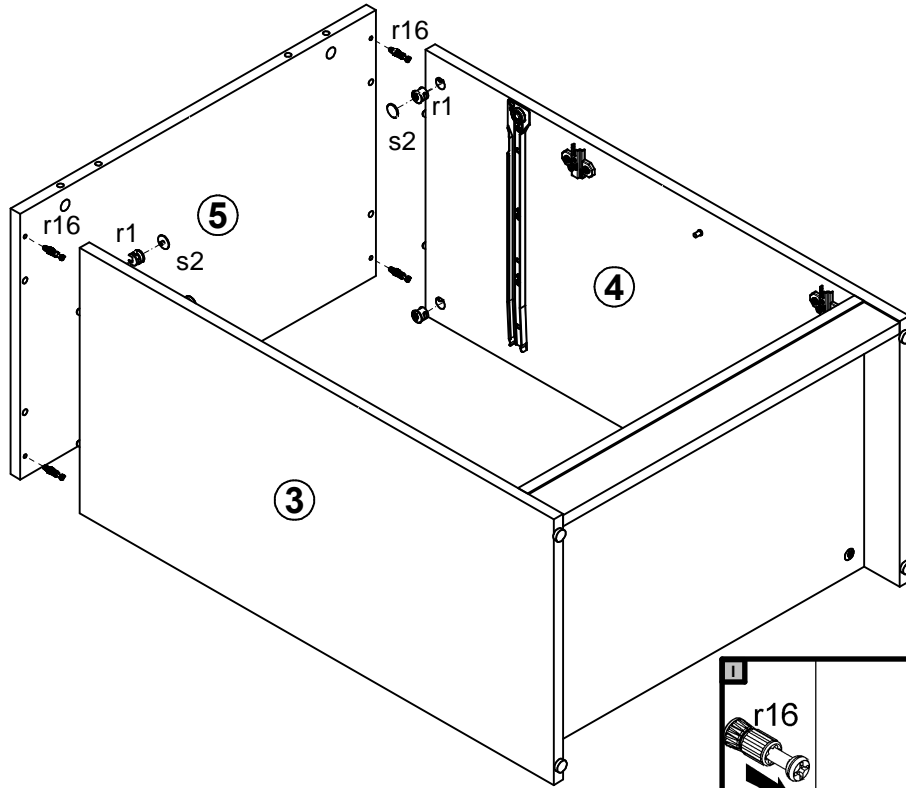

4

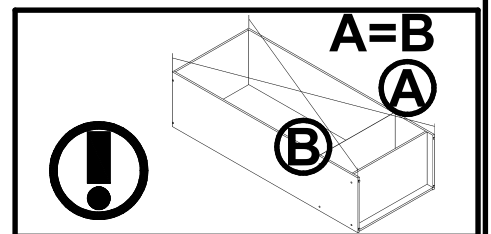
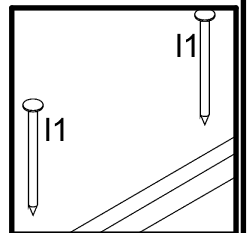
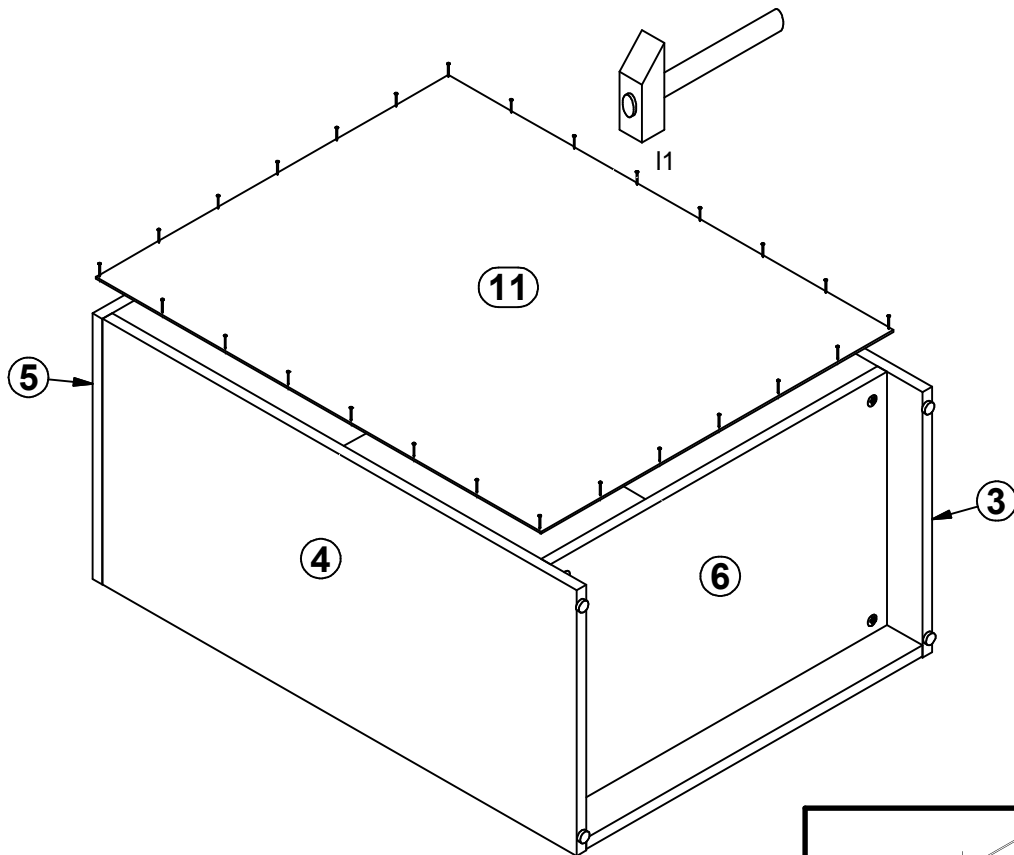

5

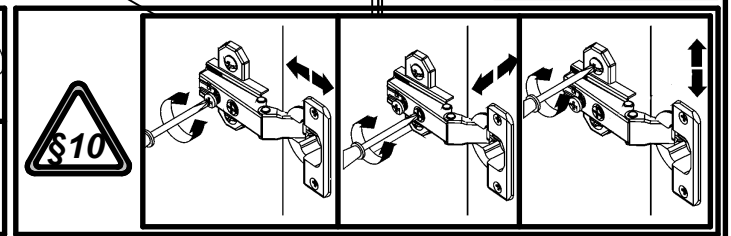
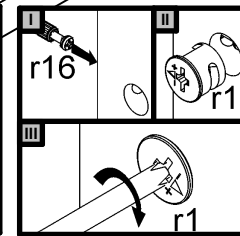
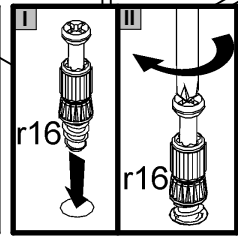
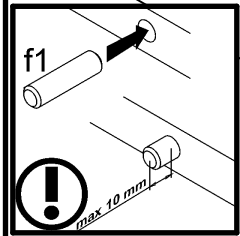
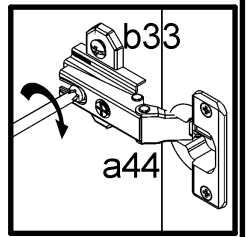
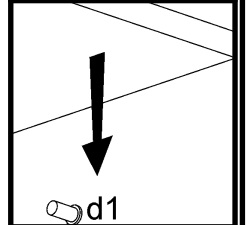
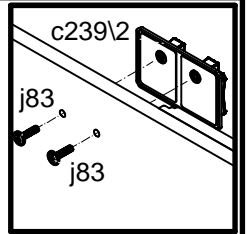
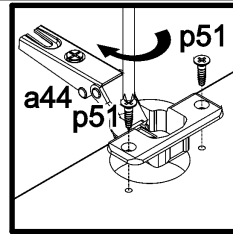
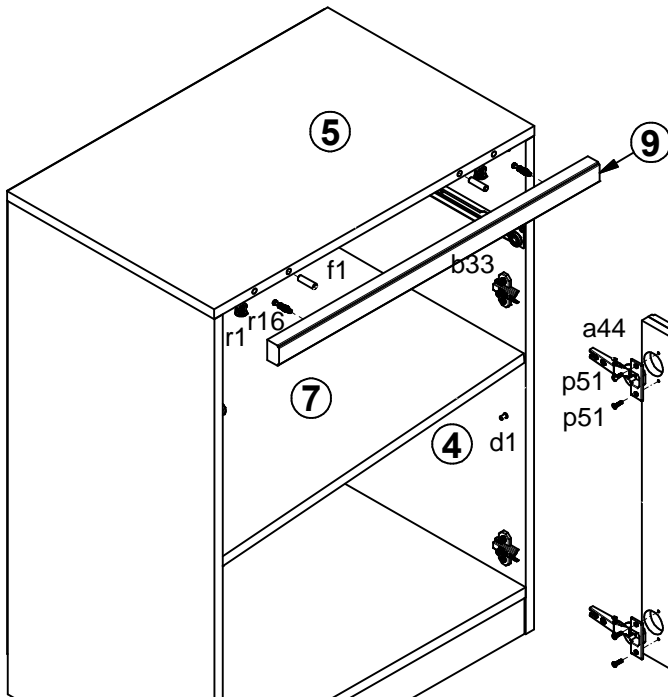

6

