

BIGGER

S78-KOM2S/50

A	B	C	D	
1	S78-017	496	160	2/2
2	S78-018	496	160	2/2
3	S78-121	405	371	1/2
4	S78-122	405	371	1/2
5	S78-204	500	371	1/2
6	S78-320	467	371	1/2
7	S78-407	467	60	1/2
8	S78-537	500	33	1/2
9	S78-909	356	495	1/2
10	S78-910	429	348	1/2
11	ZS1-529	350	120	1/2
12	ZS1-530	350	120	1/2
13	ZS1-6524	418	120	1/2

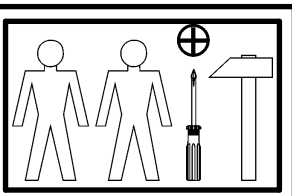
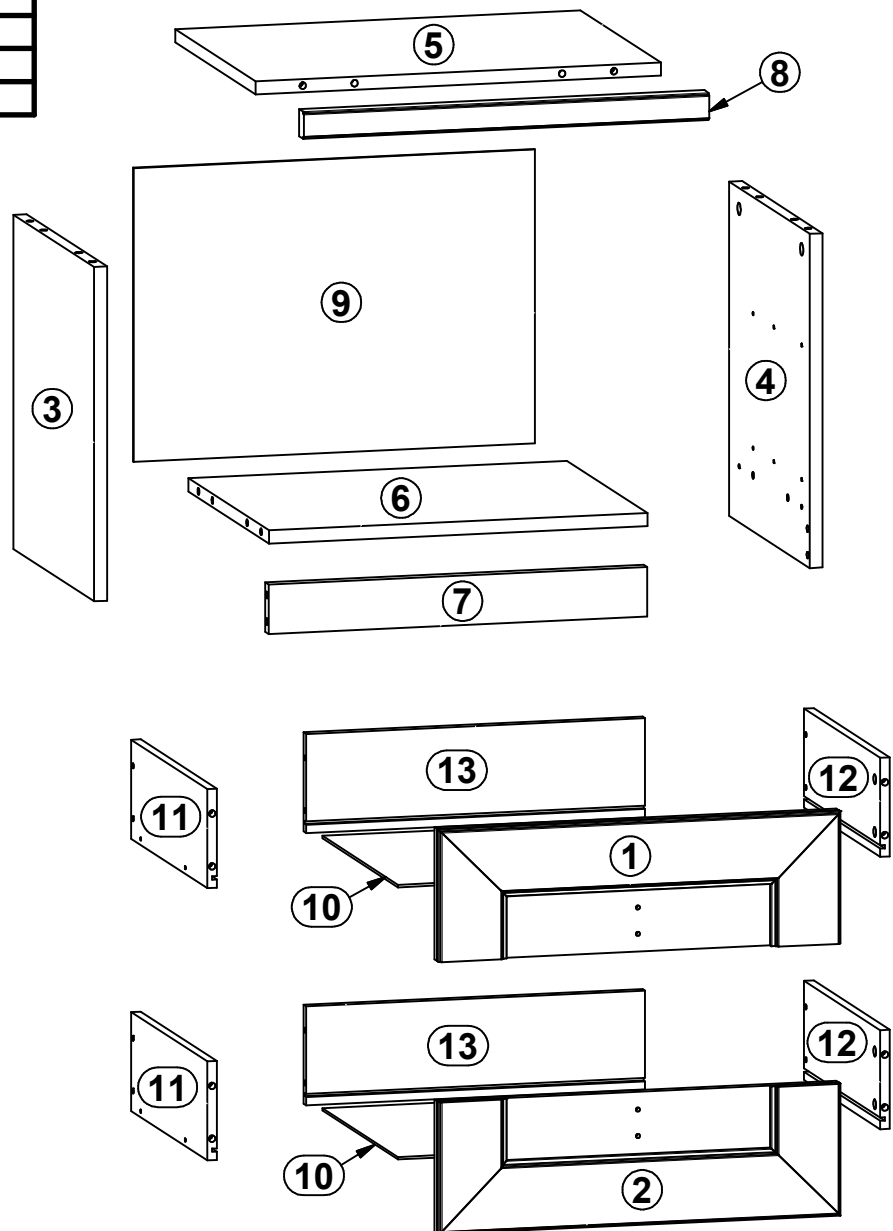
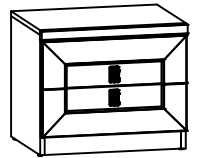

2x c239\1	8x φ5x9 mm e19	12x φ6x13 mm e3	14x φ8x30 mm f1	8x φ6.5x40 mm f25	2x M4x16 mm j83	4x k1	20x l1	10x φ1.5x12mm #16 r1
8x φ12x10.5mm #12 r15	18x r16	2x ø16 s2	2x 350 mm w45\CL	2x 350 mm w45\CR	2x 350 mm w45\DL	2x 350 mm w45\DR		

1

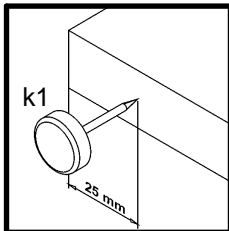
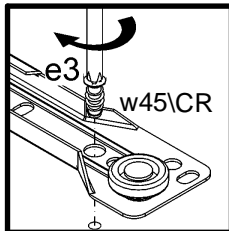
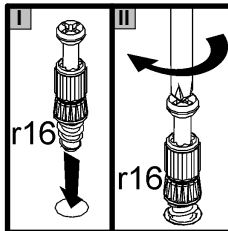
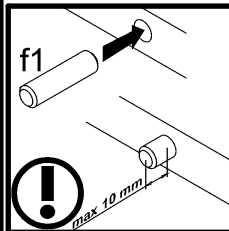
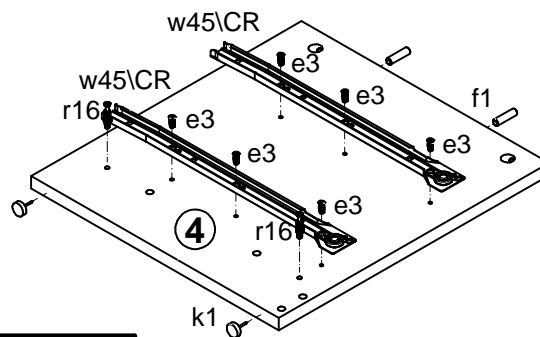
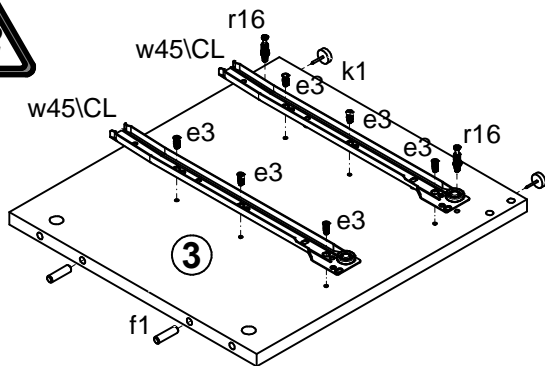

2

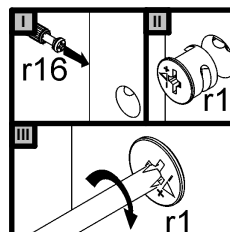
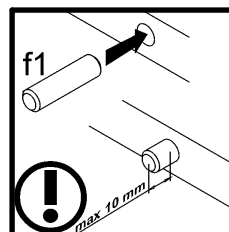
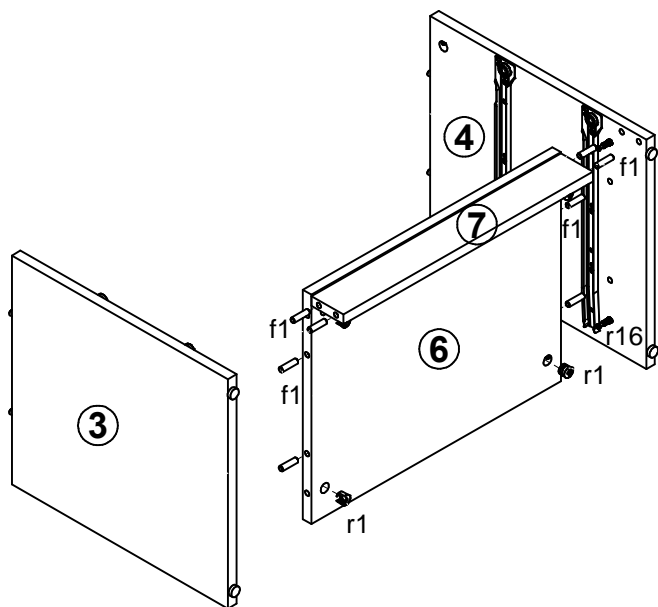

3

