

INSTRUKCJA MONTAŻU FITTING-UP INSTRUCTION AUFBAUANLEITUNG SYSTEM BRW

msu/18/7

Symbol Elementu	WYMIARY	KODY	PACZKA
1	1806x515	SB1-148	Korpus
2	1806x515	SB1-149	Korpus
3	647x499	SB1-304	Korpus
4	680x530	SB1-205	Korpus
5	680x530	SB1-241	Korpus
6	1816x327	SB1-901	Korpus
7	640	Dr-640	Korpus
8	1805x14	Lh-1805	Korpus
9	1800x336	SB1-030	Fronty

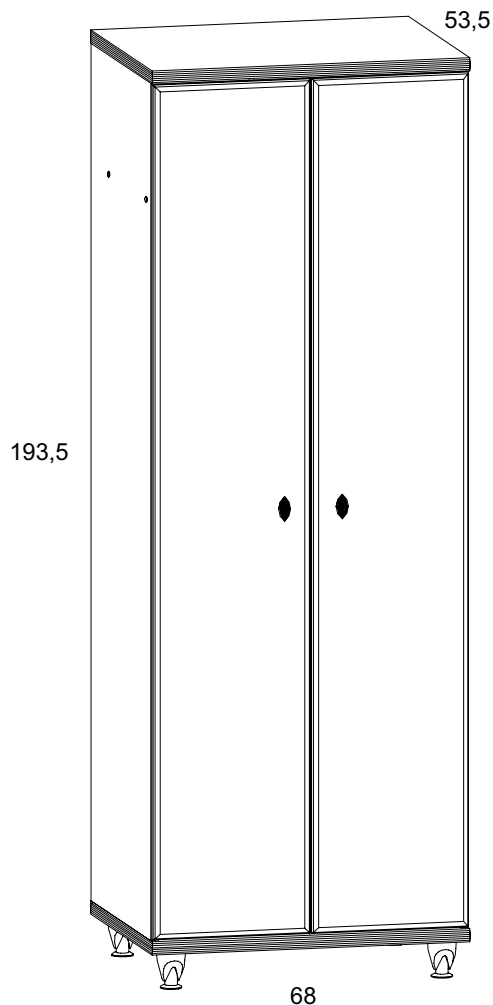

INSTRUKCJA MONTAŻU FITTING-UP INSTRUCTION AUFBAUANLEITUNG

SYSTEM BRW

msu/18/7



Paczki:/Packages:/Paketen:

Korpus /Body /Möbelkorps
Fronty/Fronts/Möbelfronten
Akcesoria/Accessories/Zubehör

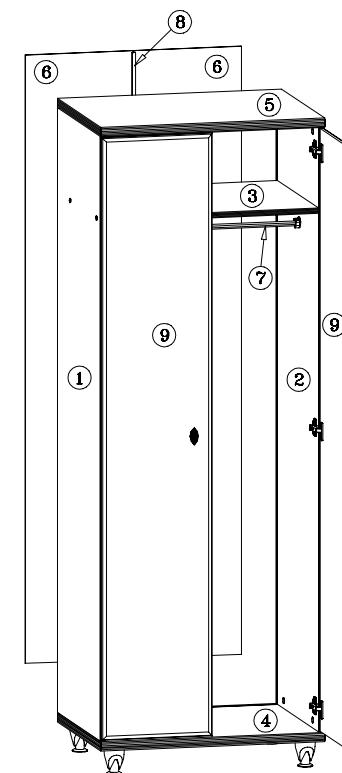

Producent:

BRW spółka z o.o.

UL. WOJSKA POLSKIEGO 3
39-300 MIELEC

193,5x68x53,5 /cm/

INFORMACJA!

Szanowny Kliencie, gdyby w zestawie paczek brakowało jakiegoś elementu, należy zaznaczyć krzyżykiem jego rysunek na instrukcji montażu (zestawienie paczek) i odesłać ją do nas.

INFORMATION!

Dear customer, if there is any element missing, you should mark it with cross in the fitting-up instruction (packages set) and send it back to us.

HINWEISS!

Sehr geehrter Kunde, soll während der Montage ein oder mehrere der dann Möbelteile fehlen bzw. beschädigt sein, soll die in dieser Anleitung angekreuzt und uns zurückgeschickt werden (Paketenzusammenfassung).

Wskazówka na temat pielęgnacji mebla.

Czyścić elementy wilgotną szmatką lub papierowym ręcznikiem.
Nie używać chemicznych środków czystości!

Direction for the furniture cleaning:

Clean elements with the moist wiper or paper towel.
Do not use any detergents!

Pflegehinweis.

Nur mit feuchtem Lappen, bzw Papiertuch Ihre Möbel reinigen. Keine chemischen Waschmittel einsetzen!

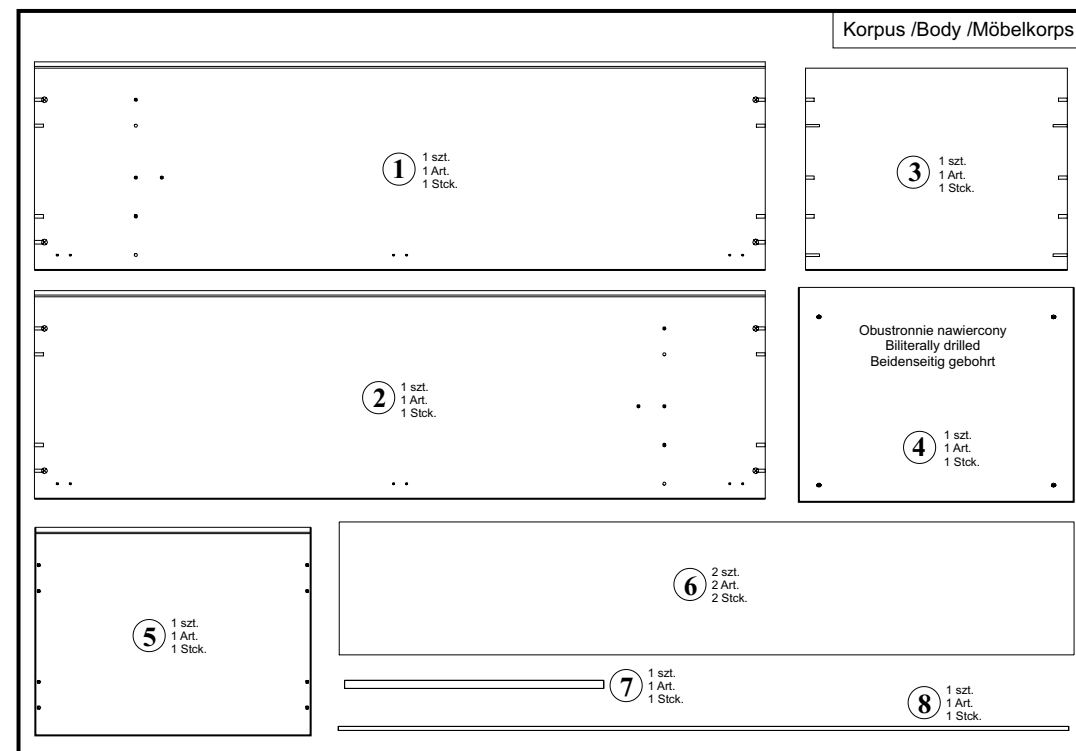

Podczas montażu
postępować
zgodnie z instrukcją.

While assembling
follow
the instruction.

Montage laut
der Aufbauanleitung
durchführen.

Podczas montażu
postępować
zgodnie z instrukcją.

While assembling
follow
the instruction.

Montage laut
der Aufbauanleitung
durchführen.

Fronty/Fronts/Möbelfronten



9 2 szt.
2 Art.
2 Stck.

Akcesoria/Accessories/Zubehör

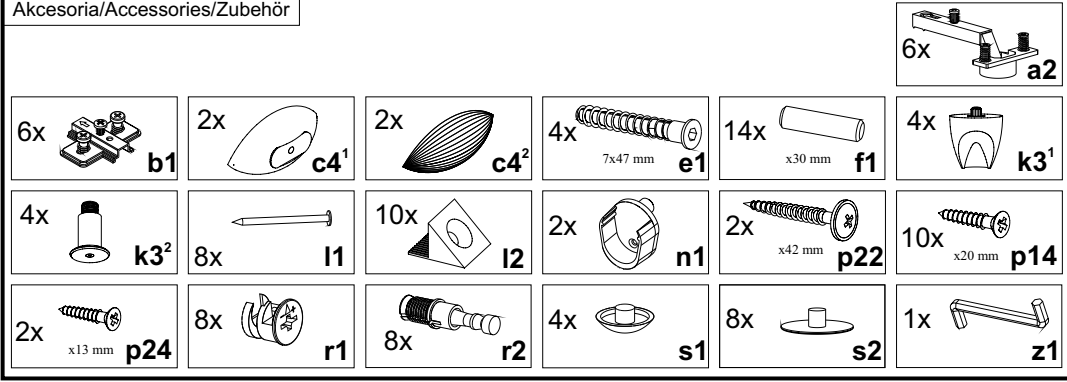

Do montażu potrzebne są:
You need for fitting-up:
Zur Montage werden Sie brauchen:

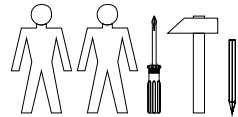

1 msu /18/7

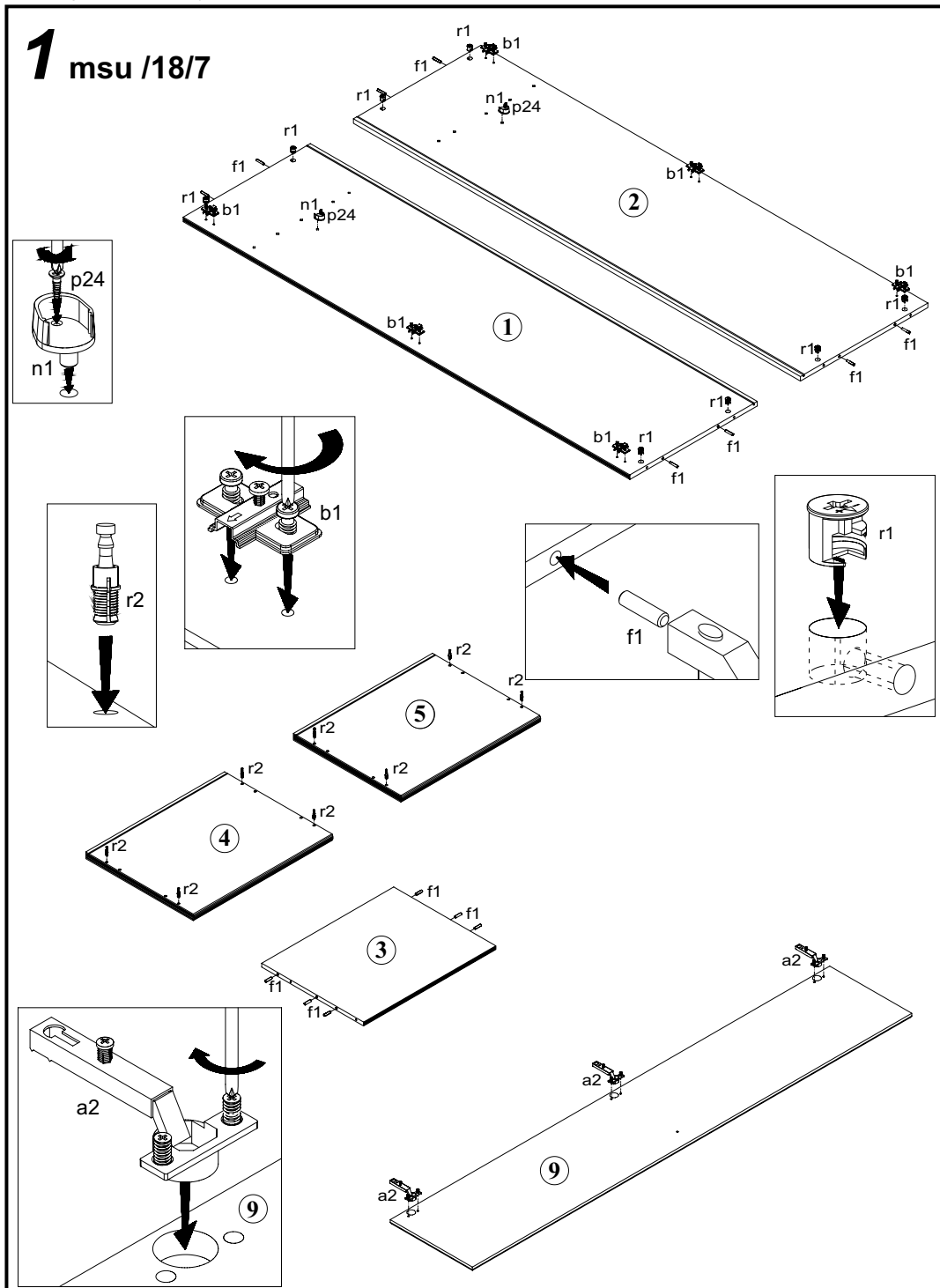

Podczas montażu
postępować
zgodnie z instrukcją.

While assembling
follow
the instruction.

Montage laut
der Aufbauanleitung
durchführen.

Podczas montażu
postępować
zgodnie z instrukcją.

While assembling
follow
the instruction.

Montage laut
der Aufbauanleitung
durchführen.

2 msu /18/7

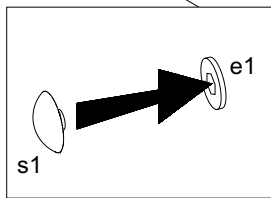
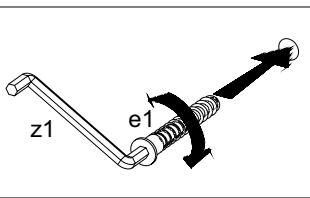
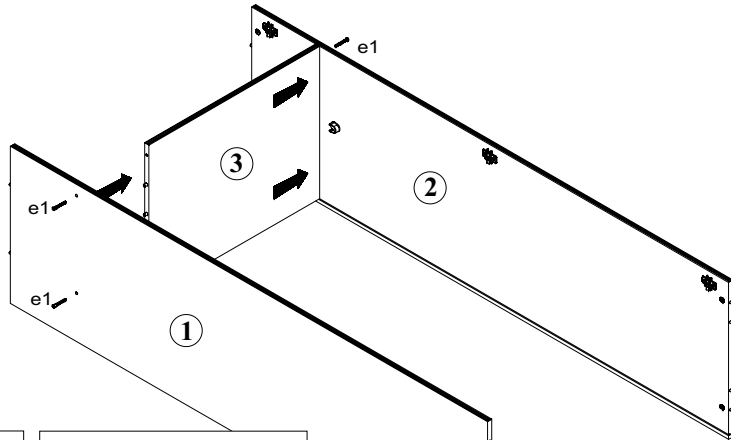

4 msu /18/7

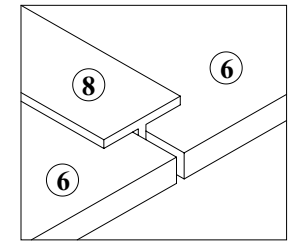
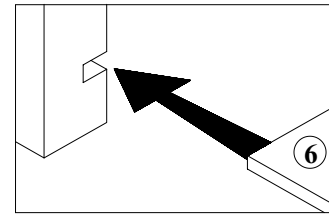
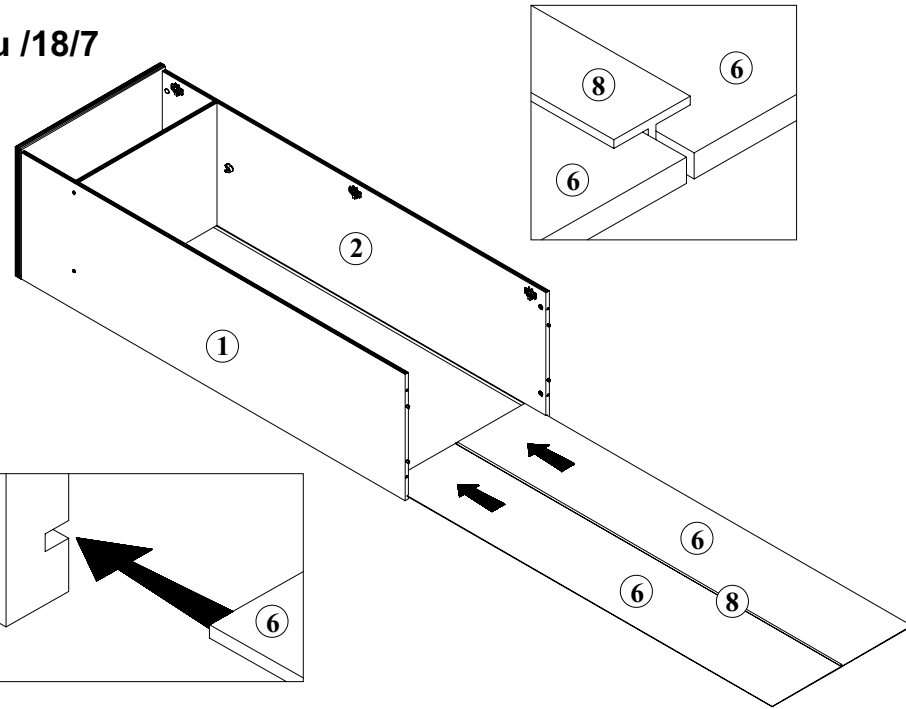

3 msu /18/7

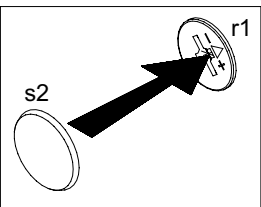
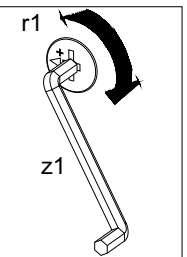
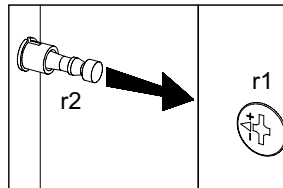
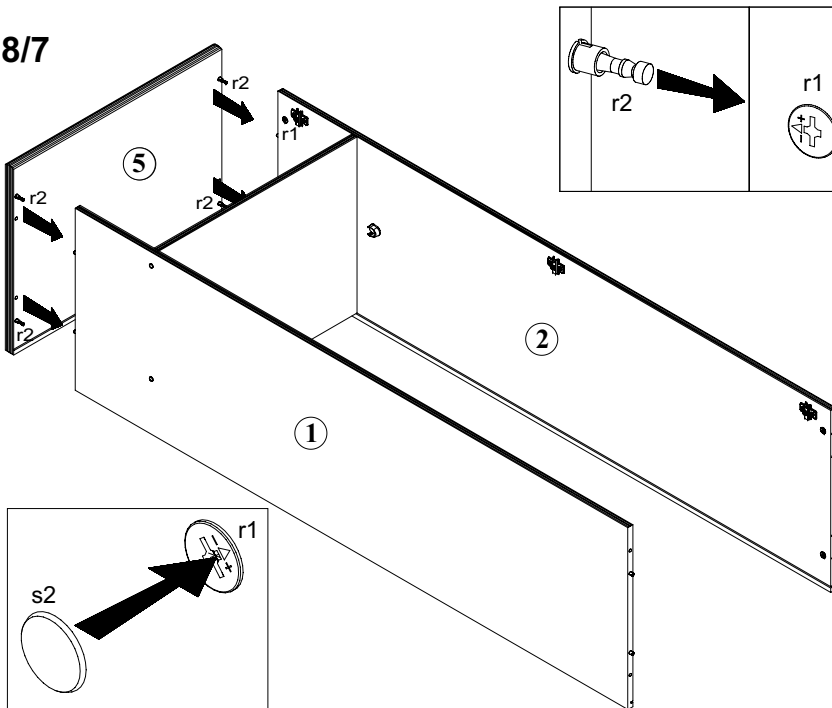

5 msu /18/7

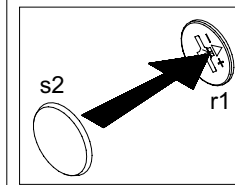
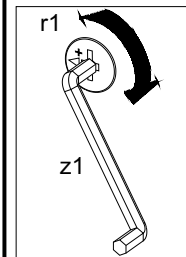
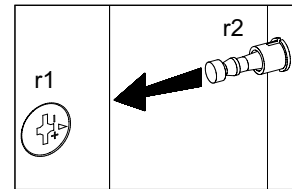
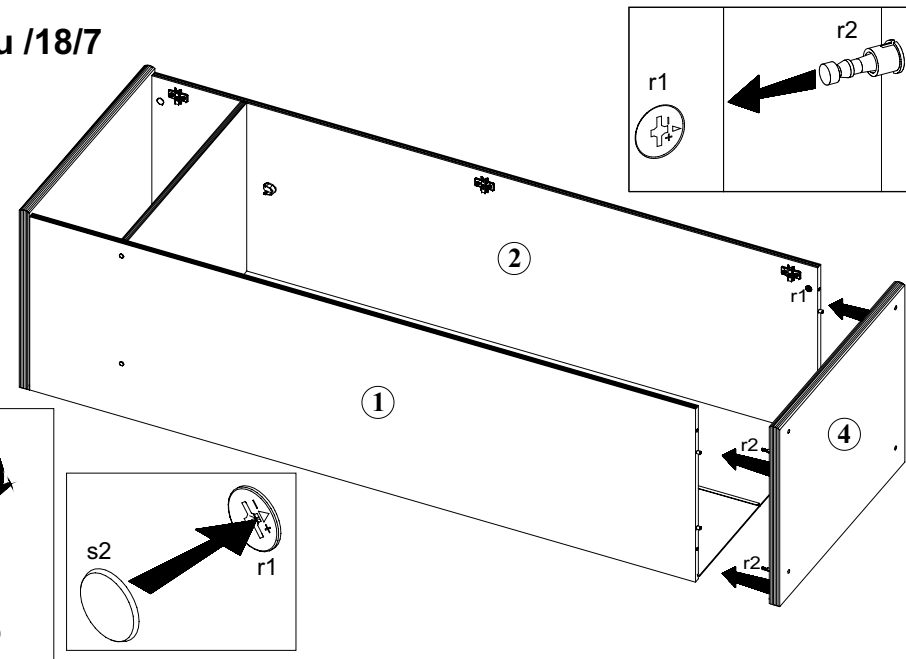

Podczas montażu
postępować
zgodnie z instrukcją.

While assembling
follow
the instruction.

Montage laut
der Aufbauanleitung
durchführen.

Podczas montażu
postępować
zgodnie z instrukcją.

While assembling
follow
the instruction.

Montage laut
der Aufbauanleitung
durchführen.

6 msu /18/7

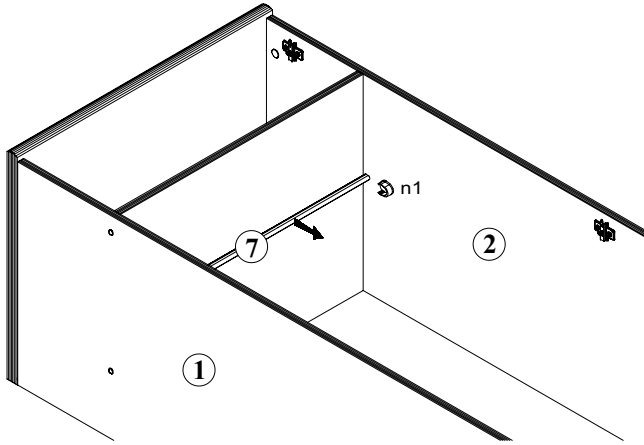
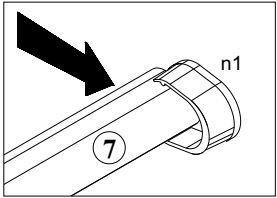

8 msu /18/7

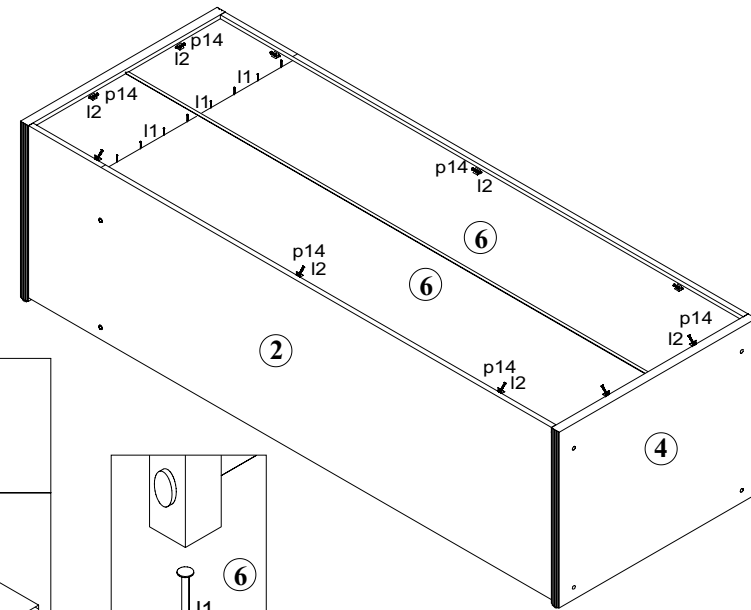
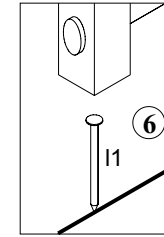
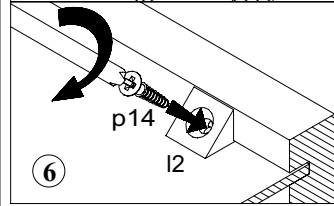
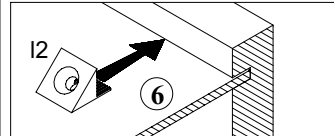
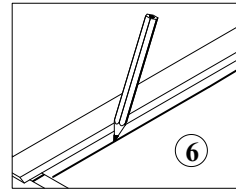

7 msu /18/7

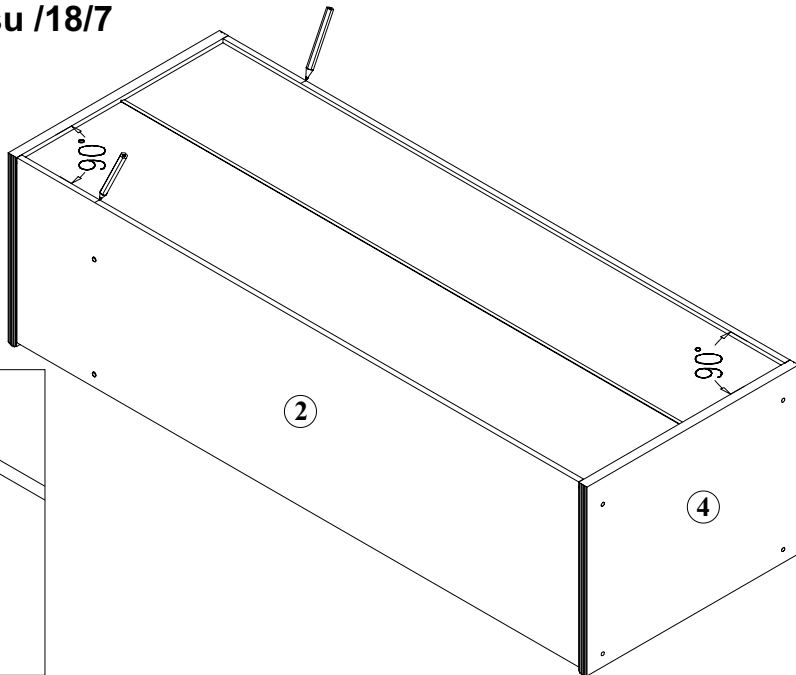
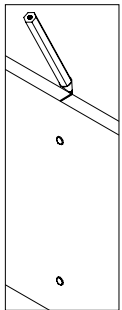

9 msu /18/7

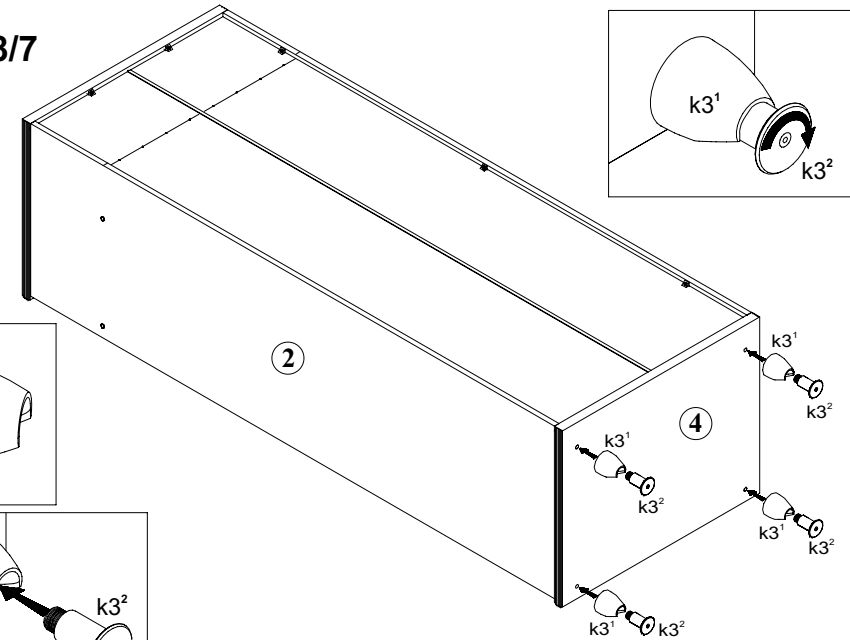
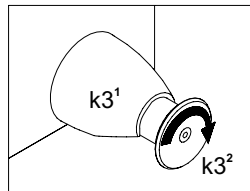
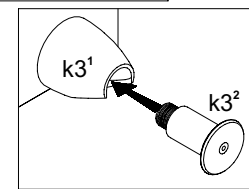
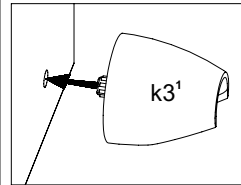

10 msu /18/7

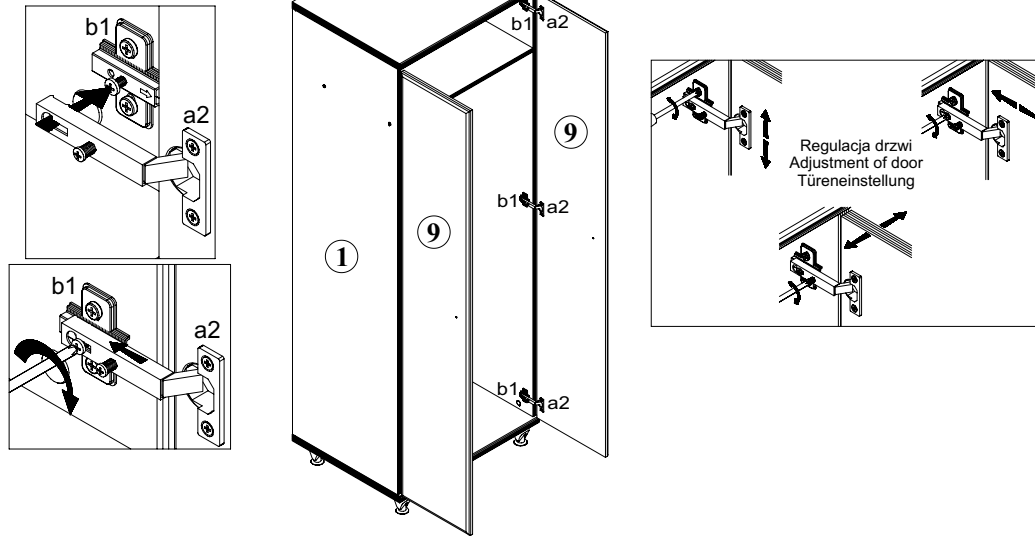

11 msu /18/7

