

INSTRUKCJA MONTAŻU
FITTING-UP INSTRUCTION
AUFBAUANLEITUNG



Producent:
BRW spółka z o.o.
 UL. WOJSKA POLSKIEGO 3
 39-300 MIELEC

SYSTEM BRW

msun/18/7

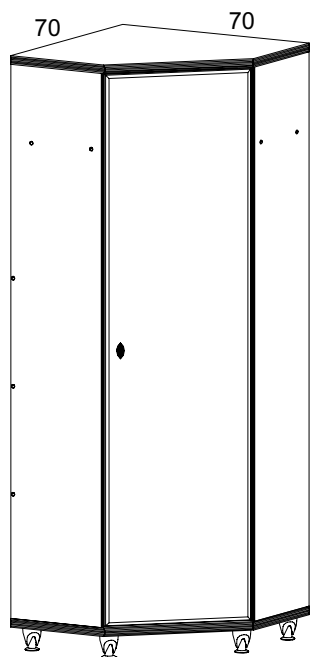

193,5

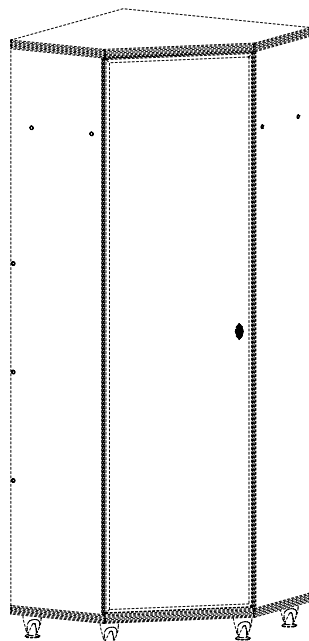

193,5x70x70 /cm/

INFORMACJA!

Szanowny Kliencie, gdyby w zestawie paczek brakowało jakiegoś elementu, należy zaznaczyć krzyżykiem jego rysunek na instrukcji montażu (zestawienie paczek) i odesłać ją do nas.

INFORMATION!

Dear customer, if there is any element missing, you should mark it with cross in the fitting-up instruction (packages set) and send it back to us.

HINWEISS!

Sehr geehrter Kunde, soll während der Montage ein oder mehrere der dann Möbelteile fehlen bzw. beschädigt sein, soll die in dieser Anleitung angekreuzt und uns zurückgeschickt werden (Paketenzusammenfassung).

Wskazówka na temat pielęgnacji mebla.

Czyścić elementy wilgotną szmatką lub papierowym ręcznikiem.
 Nie używać chemicznych środków czystości!

Direction for the furniture cleaning:

Clean elements with the moist wiper or paper towel.
 Do not use any detergents!

Pflegehinweiss.

Nur mit feuchtem Lappen, bzw Papiertuch Ihre Möbel reinigen. Keine chemischen Waschmittel einsetzen!

INSTRUKCJA MONTAŻU
FITTING-UP INSTRUCTION
AUFBAUANLEITUNG

SYSTEM BRW

msun/18/7



Paczki:/Packages:/Paketen:

Korpus /Body /Möbelkorps
 Fronty/Fronts/Möbelfronten
 Akcesoria/Accessories/Zubehör

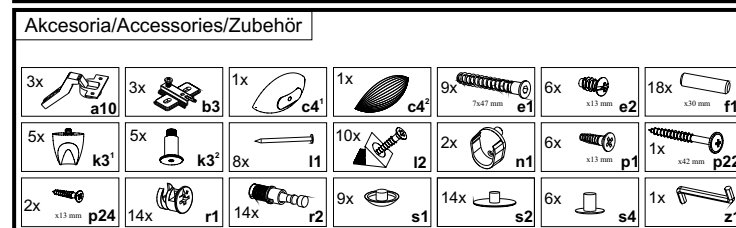
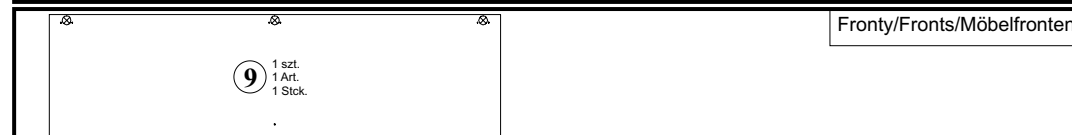
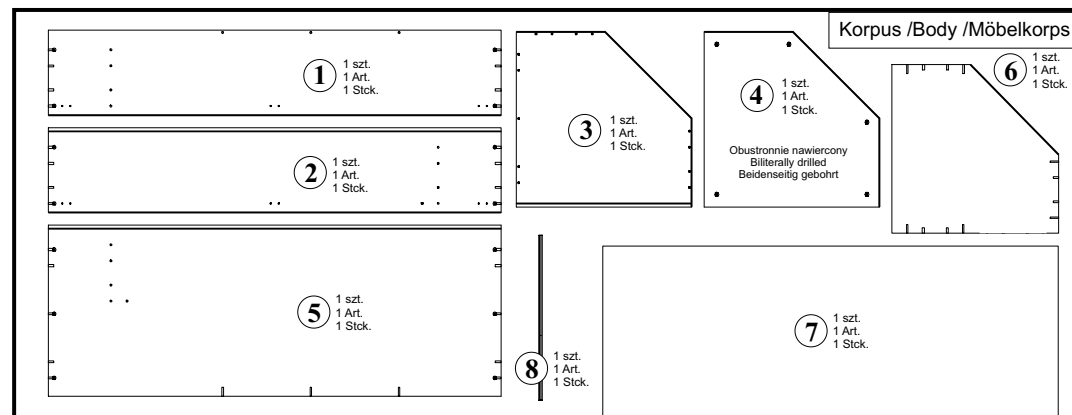
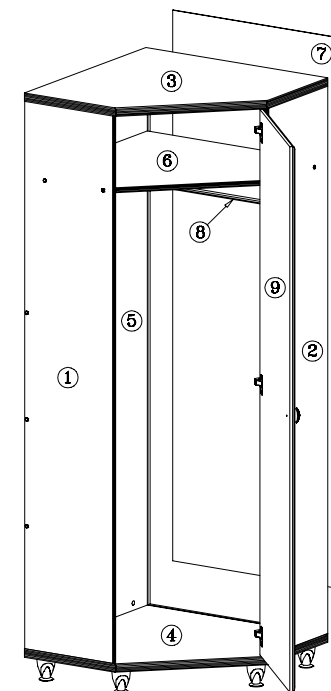

Podczas montażu
postępować
zgodnie z instrukcją.

While assembling
follow
the instruction.

Montage laut
der Aufbauanleitung
durchführen.

Podczas montażu
postępować
zgodnie z instrukcją.

While assembling
follow
the instruction.

Montage laut
der Aufbauanleitung
durchführen.

1 msun /18/7

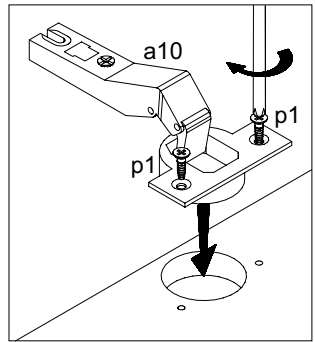
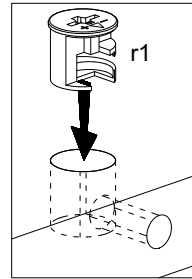
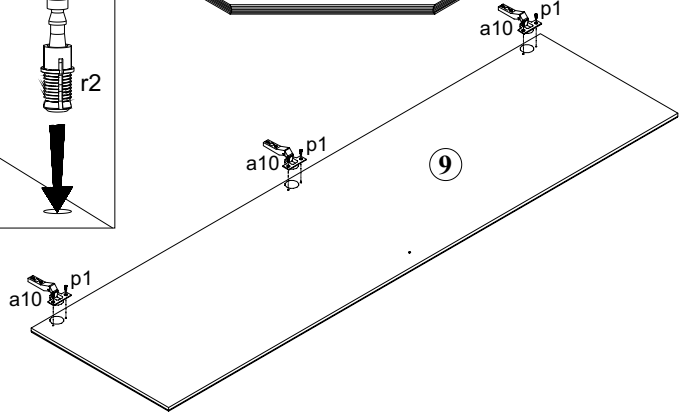
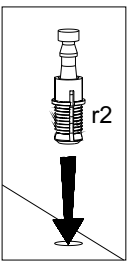
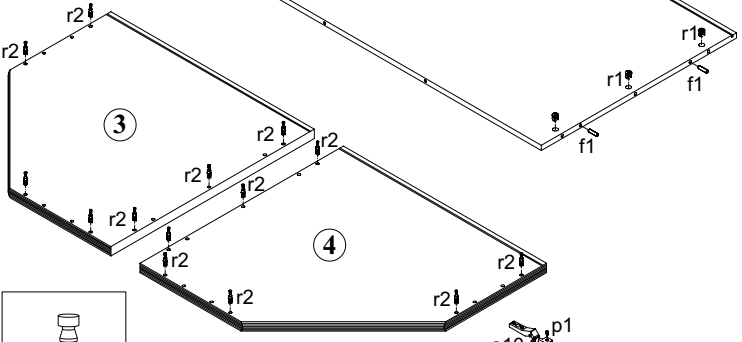
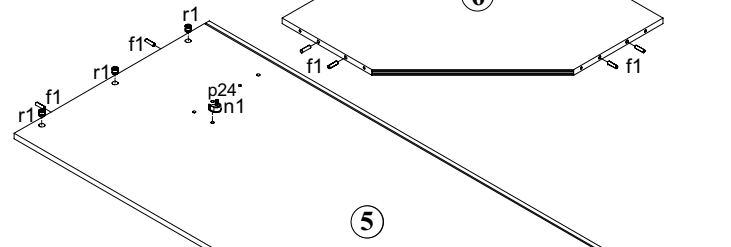
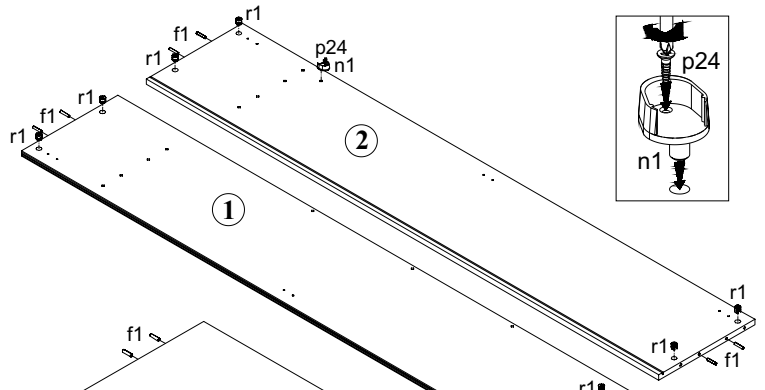
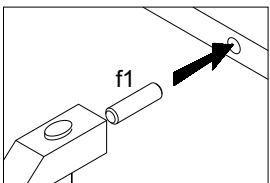

2 msun /18/7

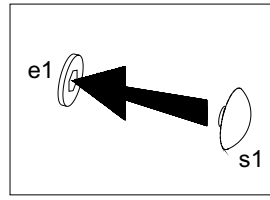
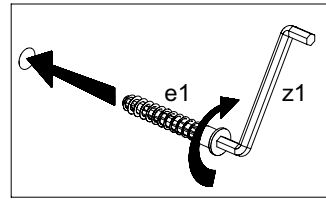
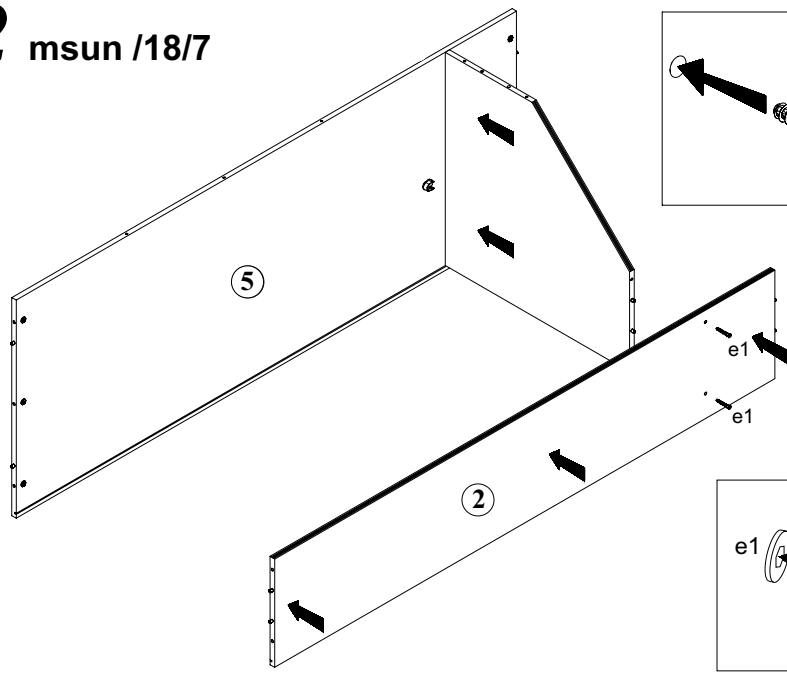

3 msun /18/7

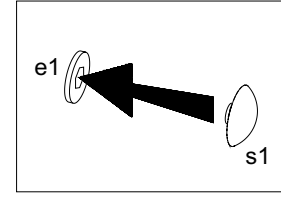
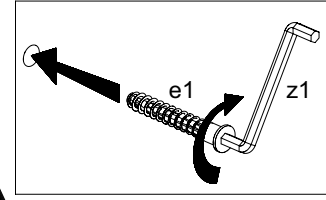
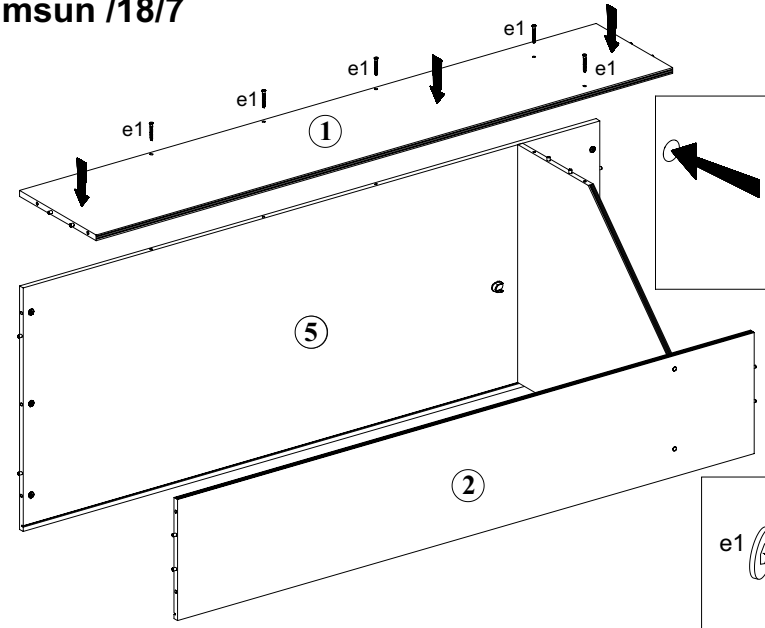

Podczas montażu
postępować
zgodnie z instrukcją.

While assembling
follow
the instruction.

Montage laut
der Aufbauanleitung
durchführen.

Podczas montażu
postępować
zgodnie z instrukcją.

While assembling
follow
the instruction.

Montage laut
der Aufbauanleitung
durchführen.

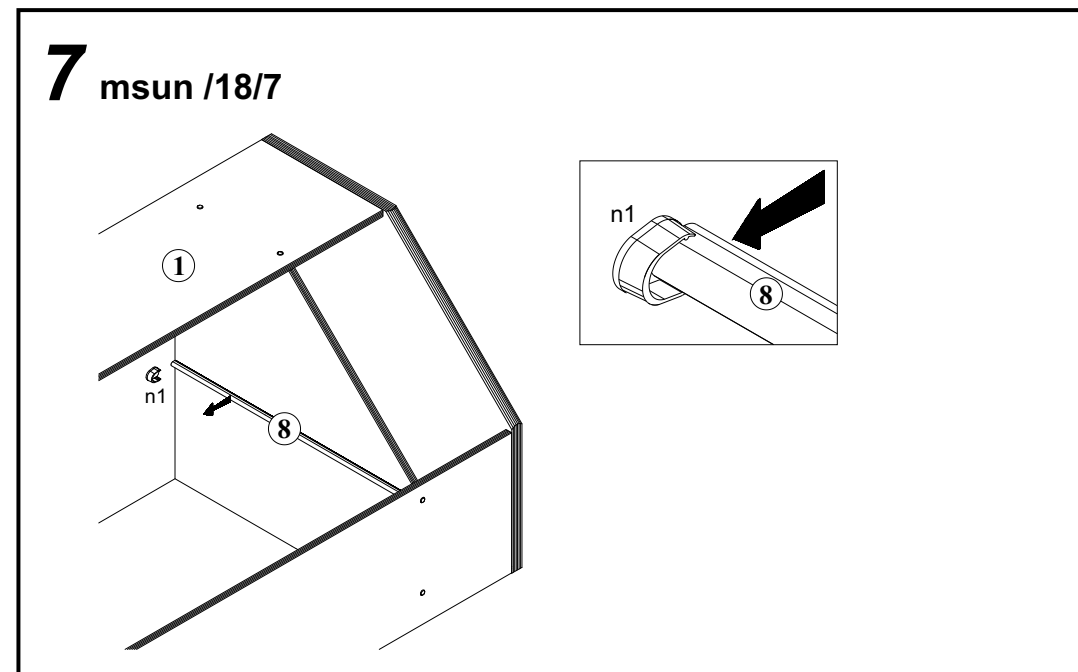
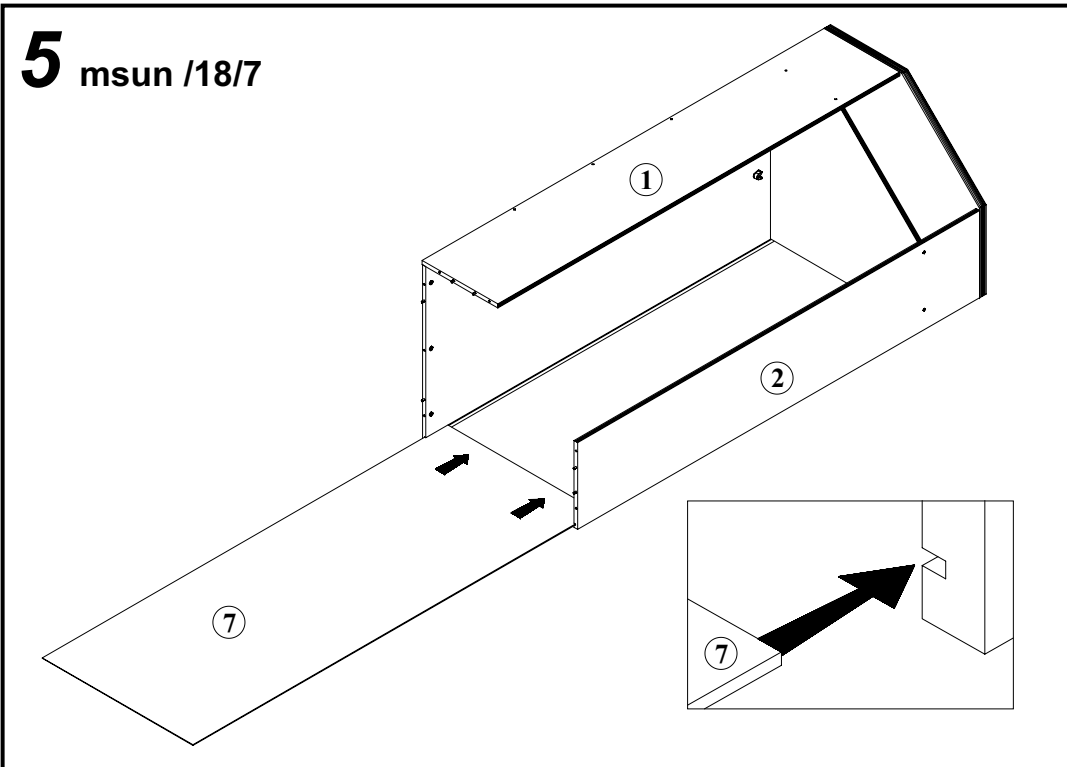
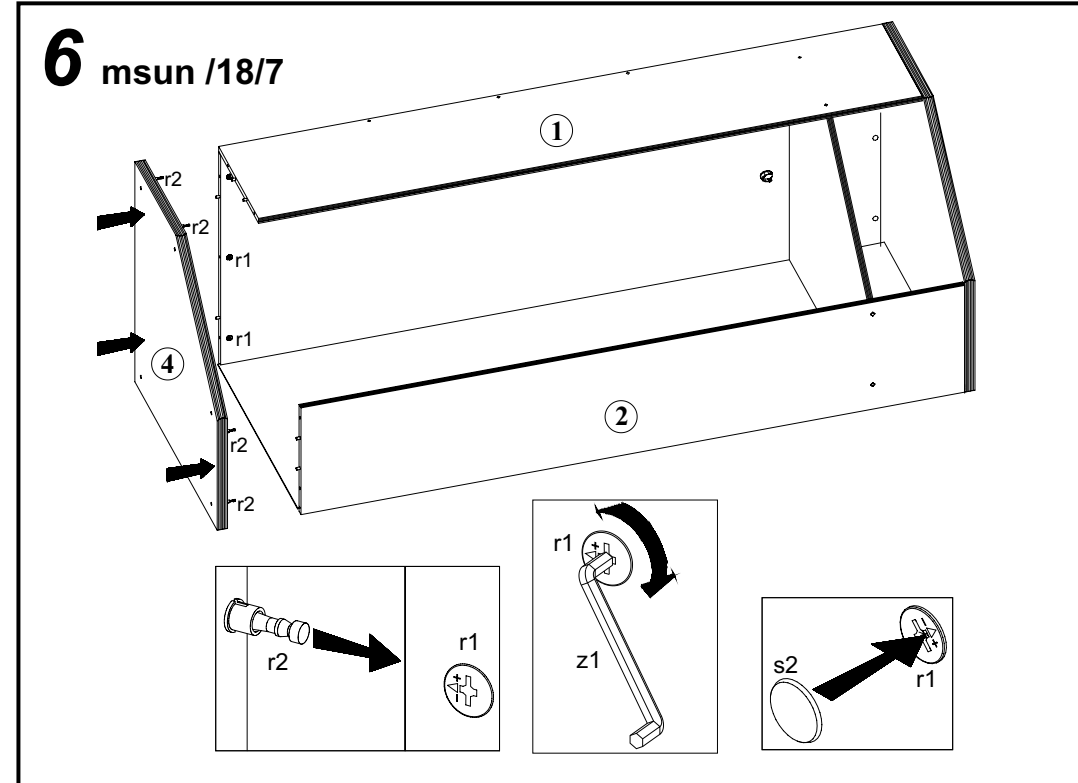
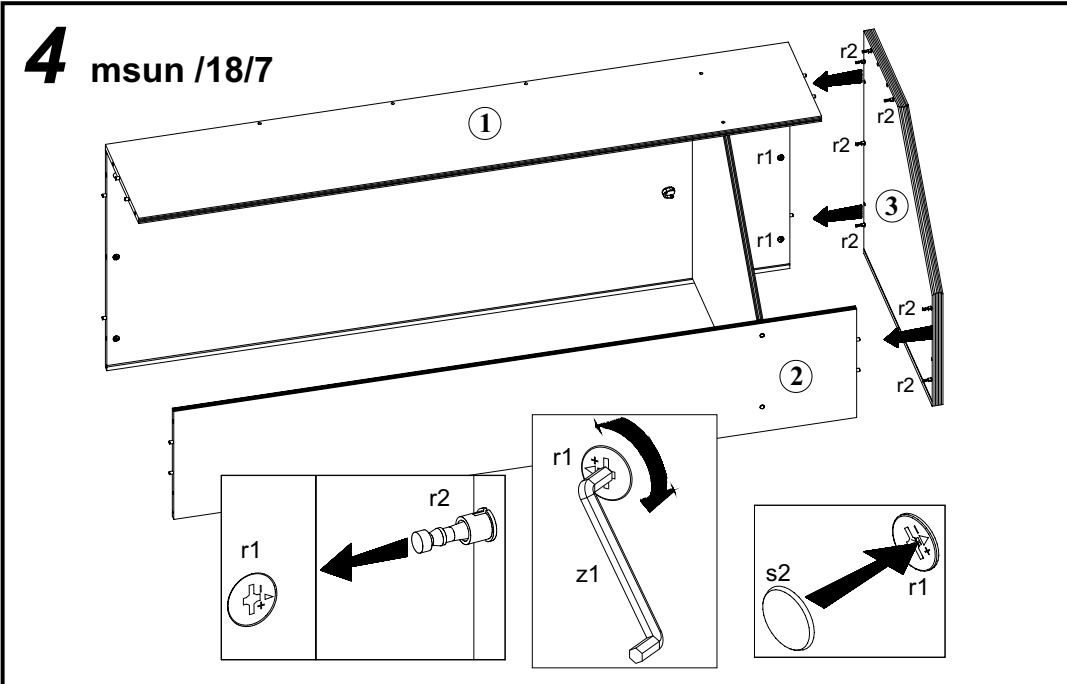

Podczas montażu
postępować
zgodnie z instrukcją.

While assembling
follow
the instruction.

Montage laut
der Aufbauanleitung
durchführen.

Podczas montażu
postępować
zgodnie z instrukcją.

While assembling
follow
the instruction.

Montage laut
der Aufbauanleitung
durchführen.

8 msun /18/7

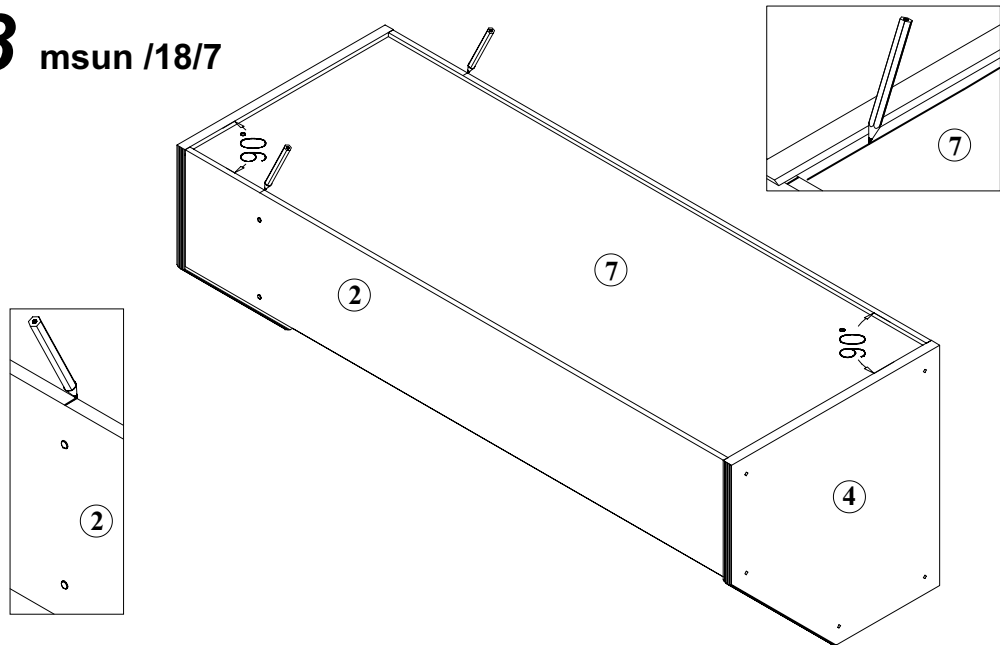

9 msun /18/7

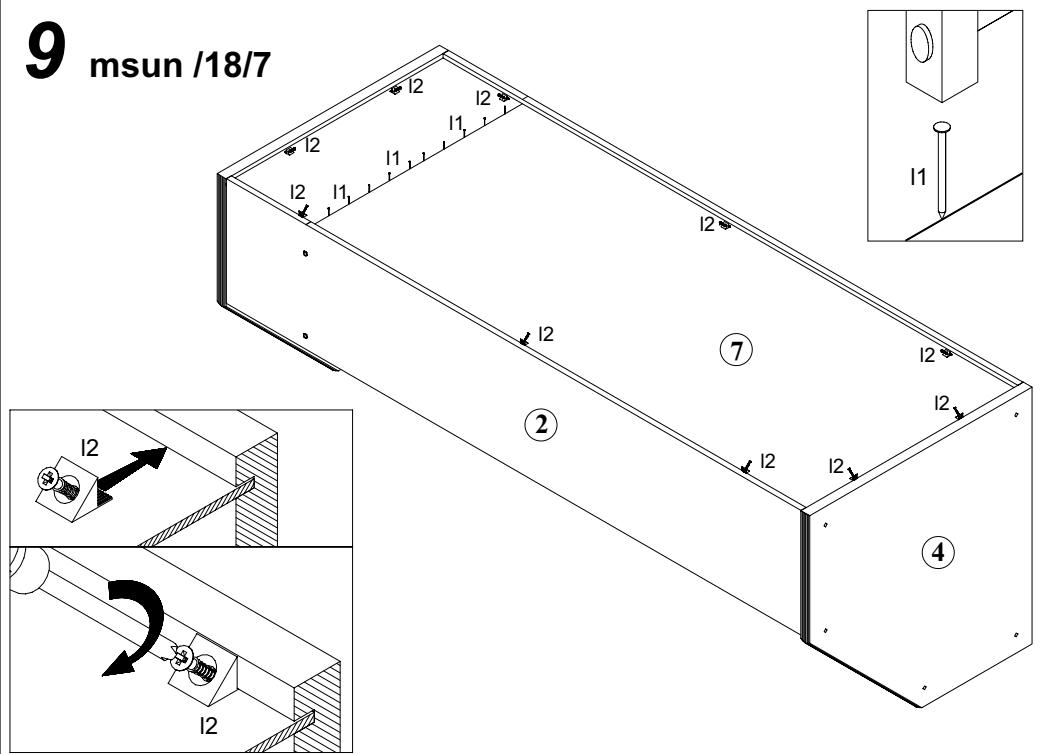

10 msun /18/7

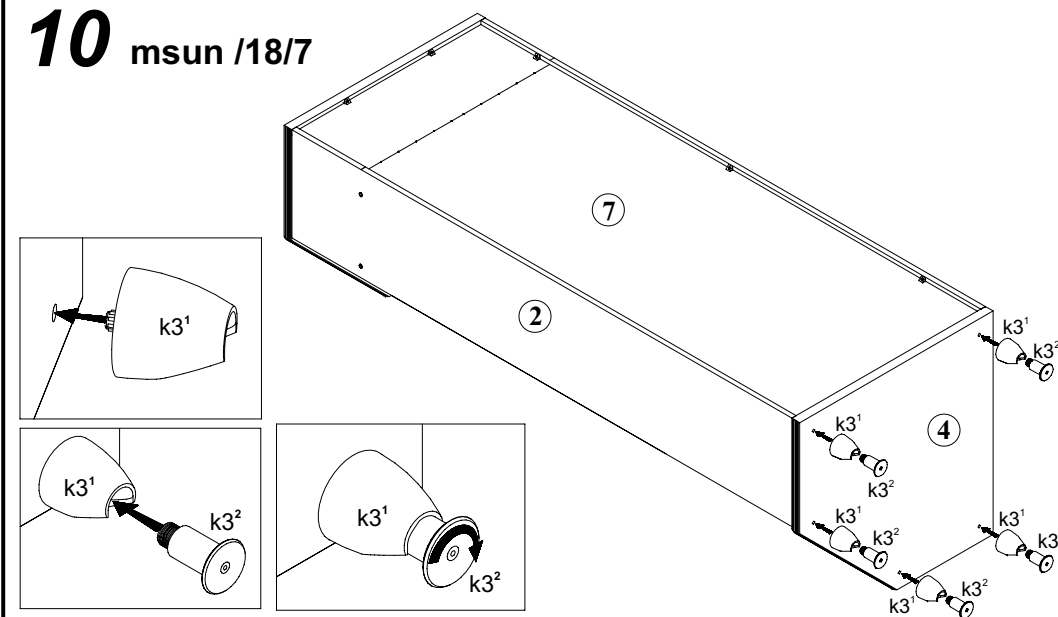

11a msun /18/7

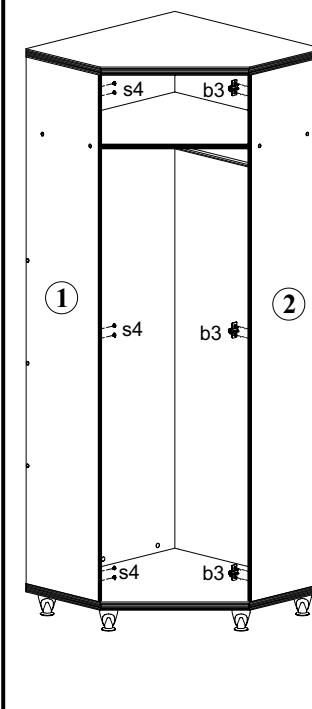

11b msun /18/7

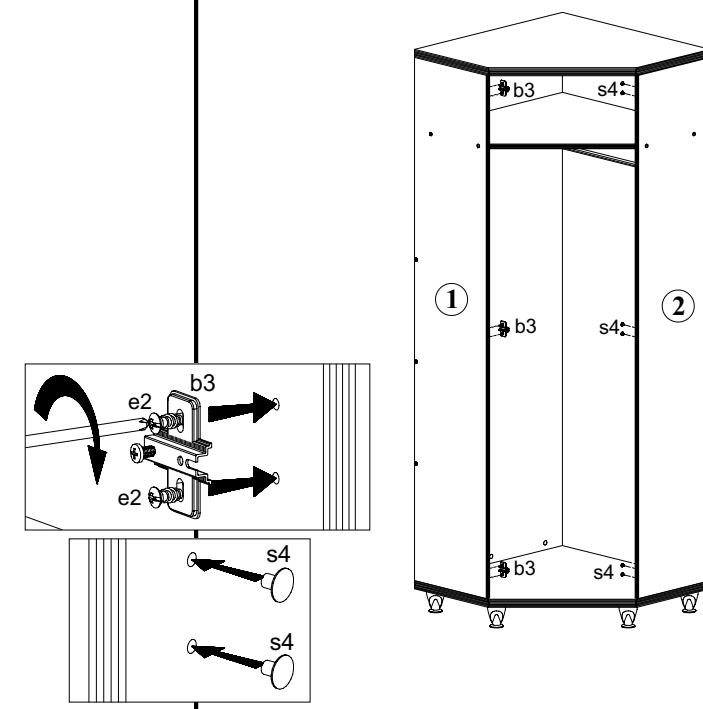

Podczas montażu
postępować
zgodnie z instrukcją.

While assembling
follow
the instruction.

Montage laut
der Aufbauanleitung
durchführen.

12a msun /18/7

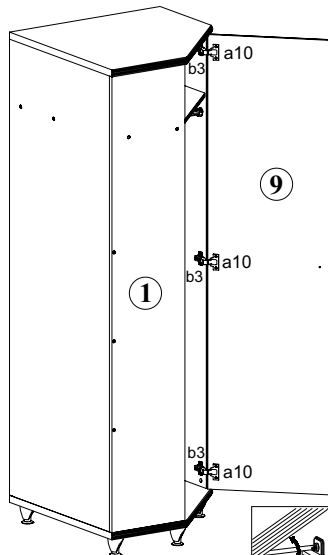

12b msun /18/7

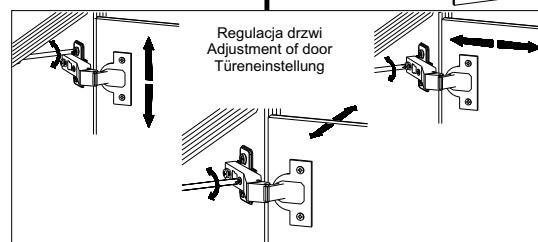
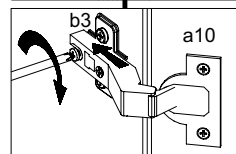
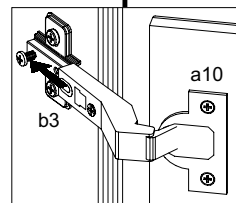
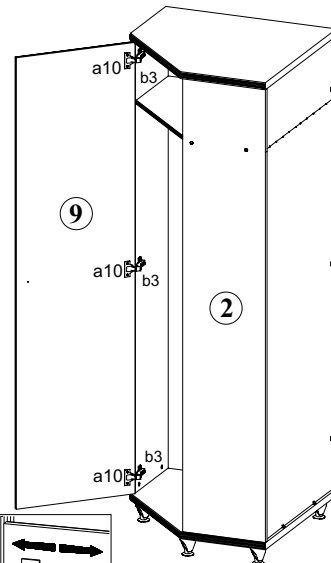

Symbol Elementu	WYMIARY	KODY	PACZKA
1	1806x339	SB1-162	Korpus
2	1806x339	SB1-163	Korpus
3	699x699	SB1-246	Korpus
4	699x699	SB1-245	Korpus
5	1806x682	SB1-413	Korpus
6	666x666	SB1-347	Korpus
7	1816x676	SB1-936	Korpus
8	659	DR-659	Korpus
9	1800x486	SB1-043	Fronty

13 msun /18/7

