

A	B	C	D	A	B	C	D		
1	S305-010	446	196	4/5	14	S305-503	1490	80	3/5
2	S305-011	446	100	4/5	15	S305-510	400	60	1/5
3	S305-012	772	396	5/5	16	S305-511	400	60	1/5
4	S305-013	772	396	5/5	17	S305-520	918	120	3/5
5	S305-112	918	403	1/5	18	S305-521	918	120	3/5
6	S305-113	918	403	1/5	19	S305-906	875	446	1/5
7	S305-114	843	403	1/5	20	S305-907	404	405	1/5
8	S305-115	843	403	1/5	21	S305-908	875	519	1/5
9	S305-205	1489	403	2/5	22	ZS3-5581	382	60	1/5
10	S305-307	1458	403	2/5	23	ZS3-5582	382	140	1/5
11	S305-308	498	402	1/5	24	ZS4-527	400	140	1/5
12	S305-415	431	56	2/5	25	ZS4-528	400	140	1/5
13	S305-416	1458	56	2/5					

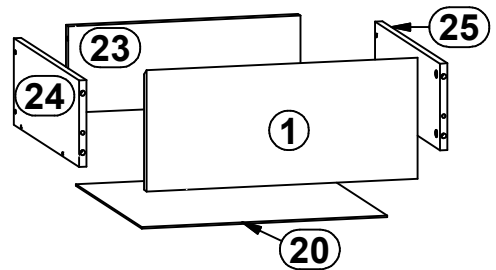

4x a99	4x b43	8x d1 Ø5x17 mm	4x e1 Ø7x50 mm	10x e2 Ø6.3x13 mm	24x e3 Ø6x13 mm	16x e19 Ø5x9 mm	36x f1 Ø8x30 mm	6x f9 Ø6x30 mm
16x f25 Ø6.5x40 mm	4x k1	2x k38\3	2x k38\8	85x l1	24x p38 Ø3.5x16 mm	8x p51 Ø3.5x15 mm	28x r1 Ø15x12 mm #16	16x r15 Ø12x10.5 mm #12
40x r42	2x r51	8x s2 Ø16	4x w5\CL 400 mm	4x w5\CR 400 mm	4x w5\DL 400 mm	4x w5\DR 400 mm	1x z1	1x n26\1
1x p38 Ø3.5x16 mm								

1

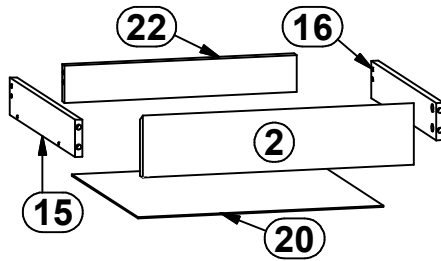
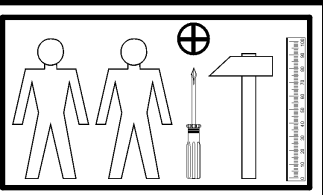
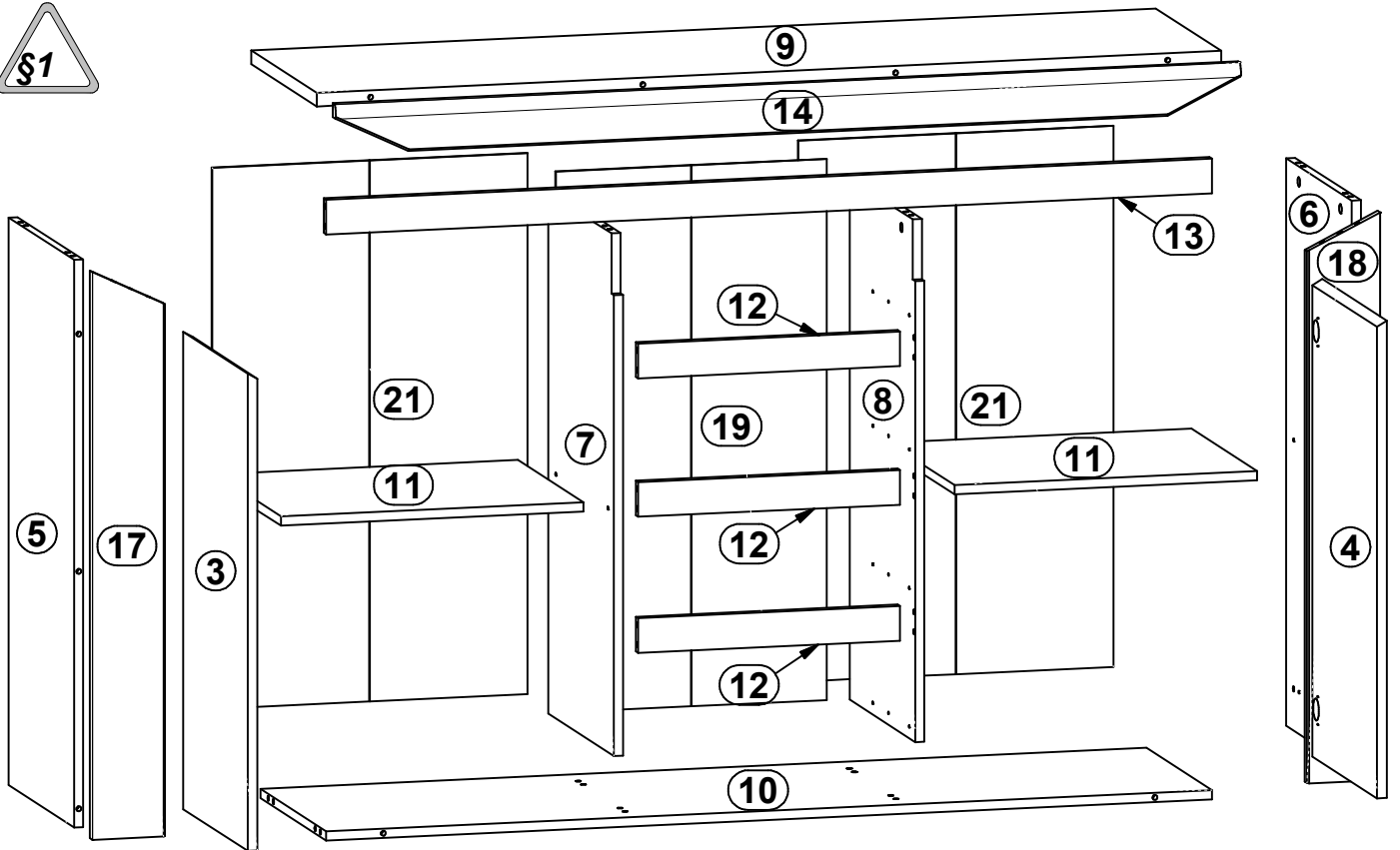
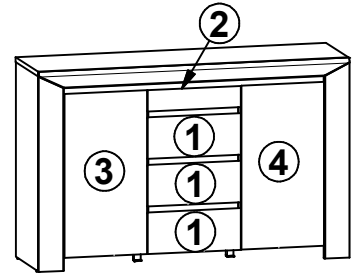
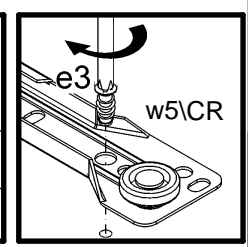
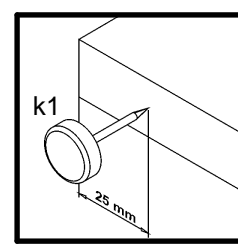
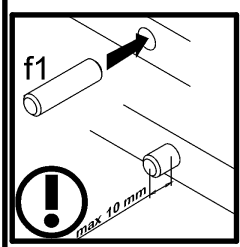
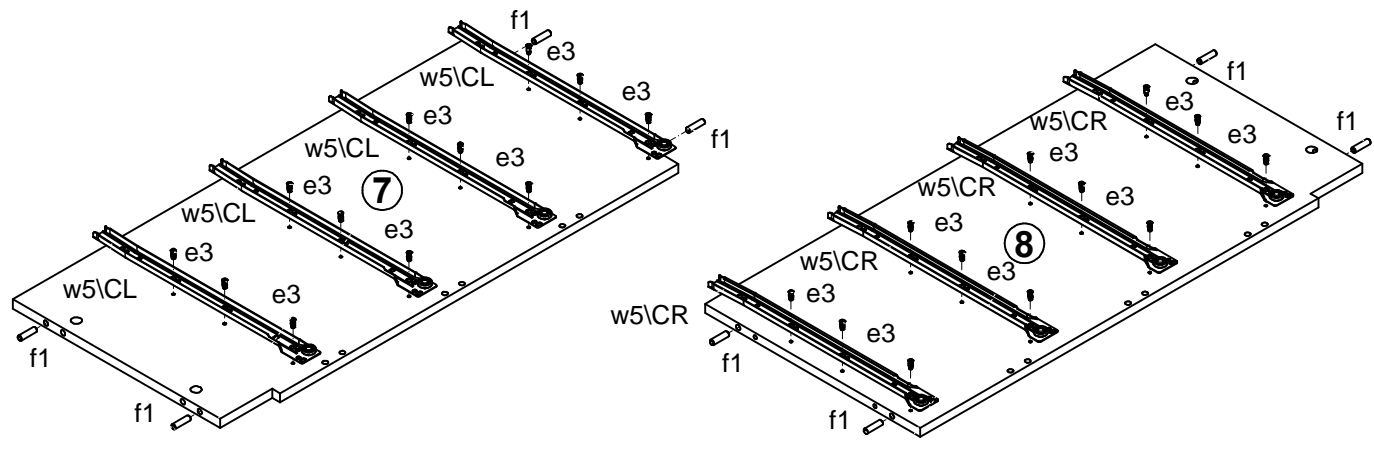
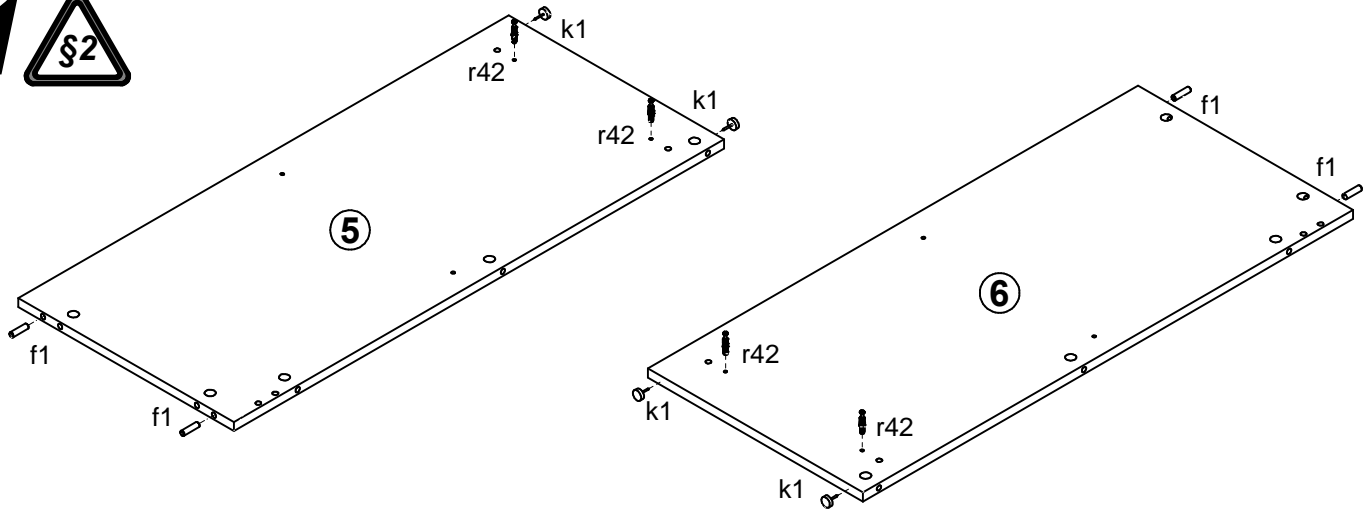

2

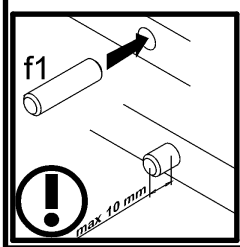
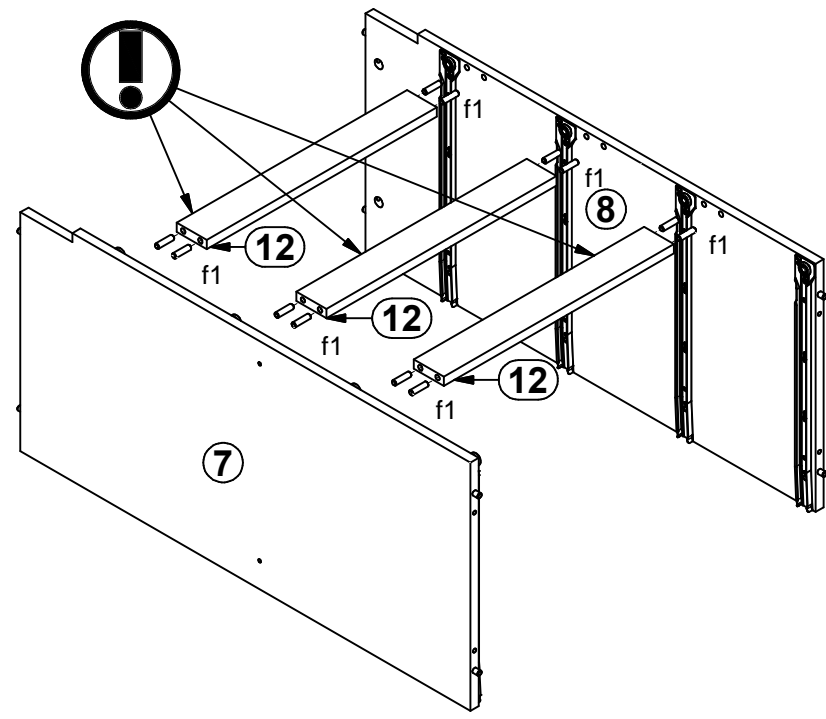

3

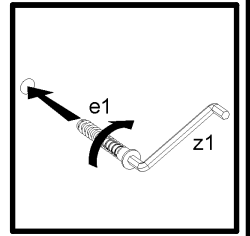
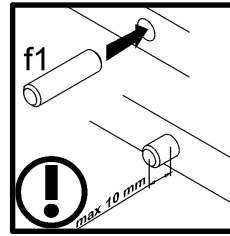
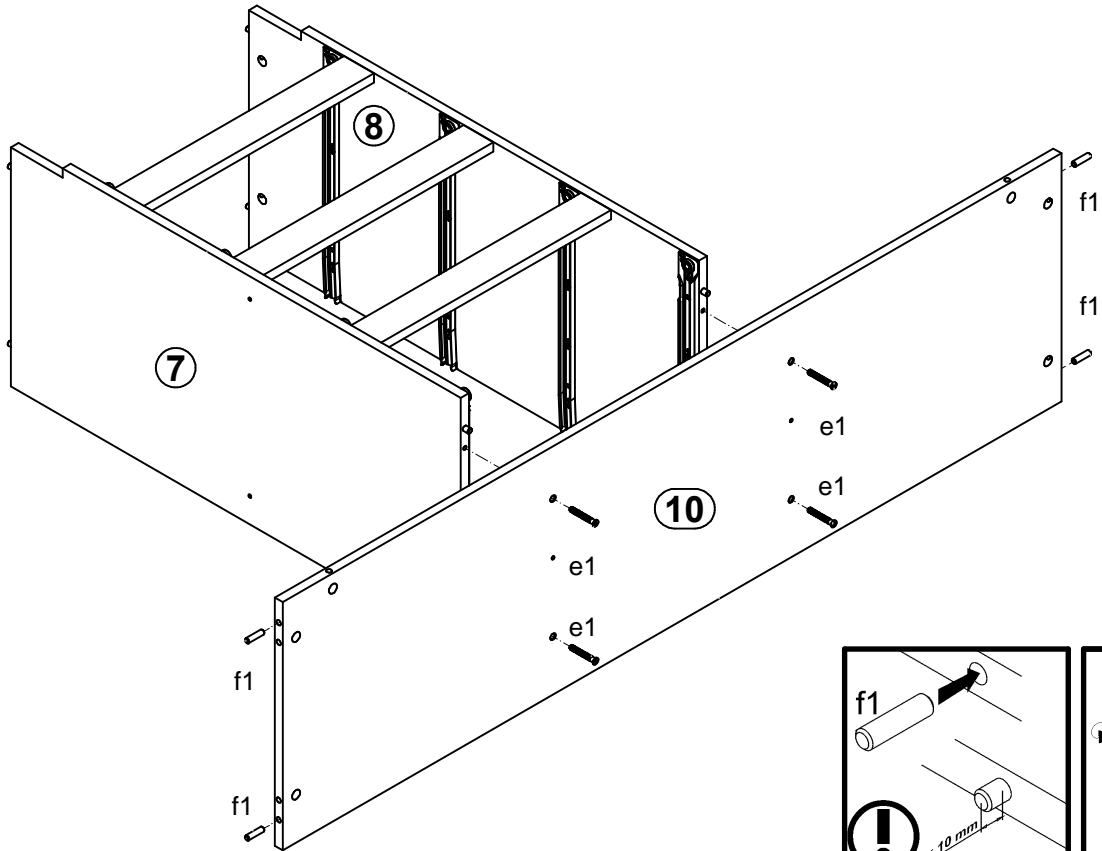

4

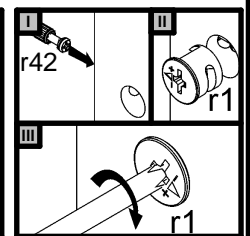
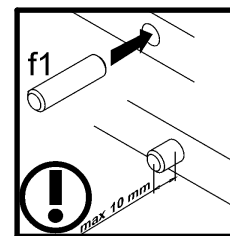
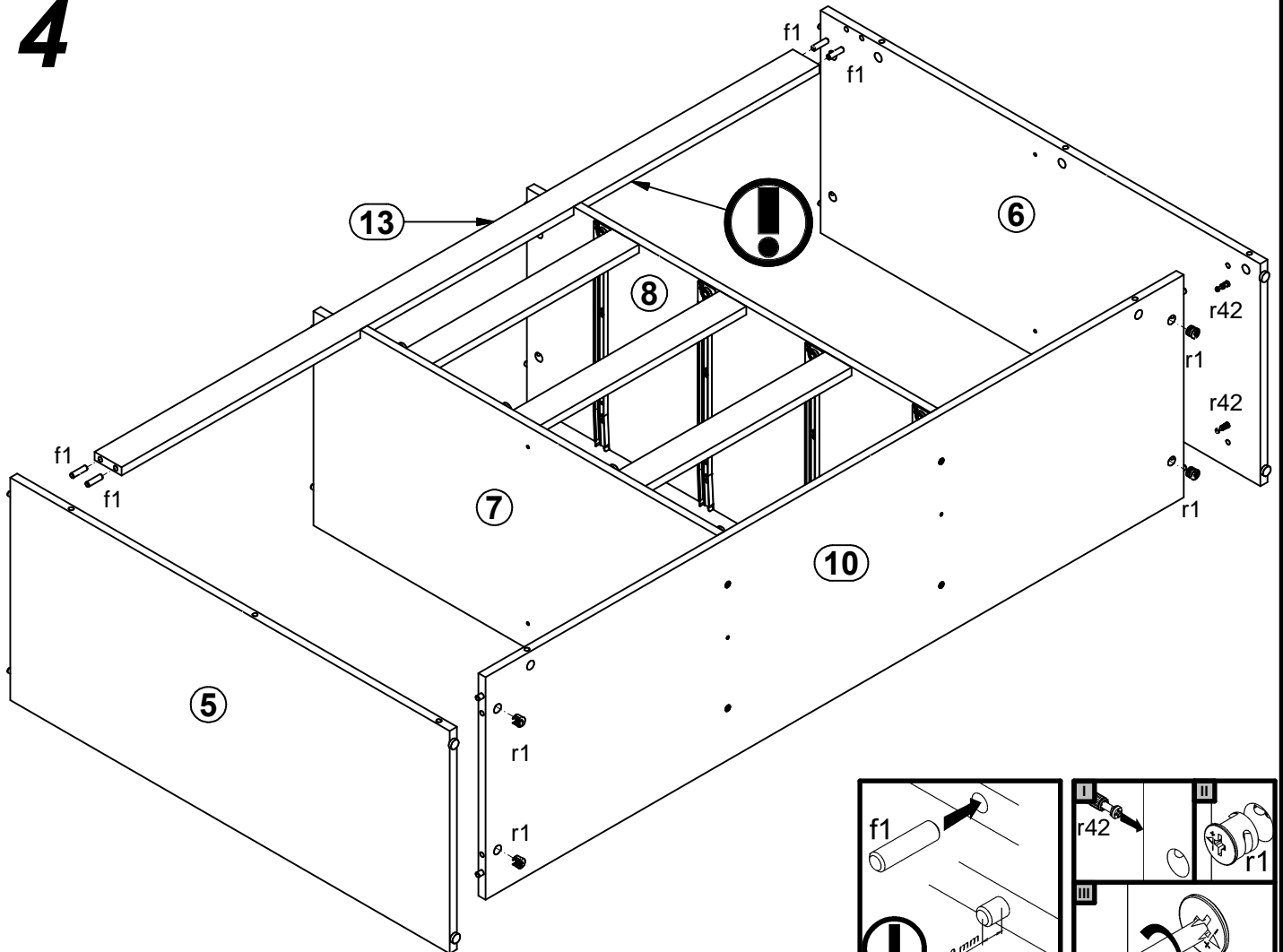

5

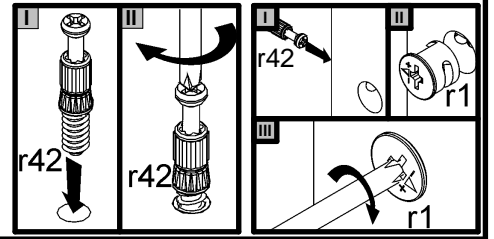
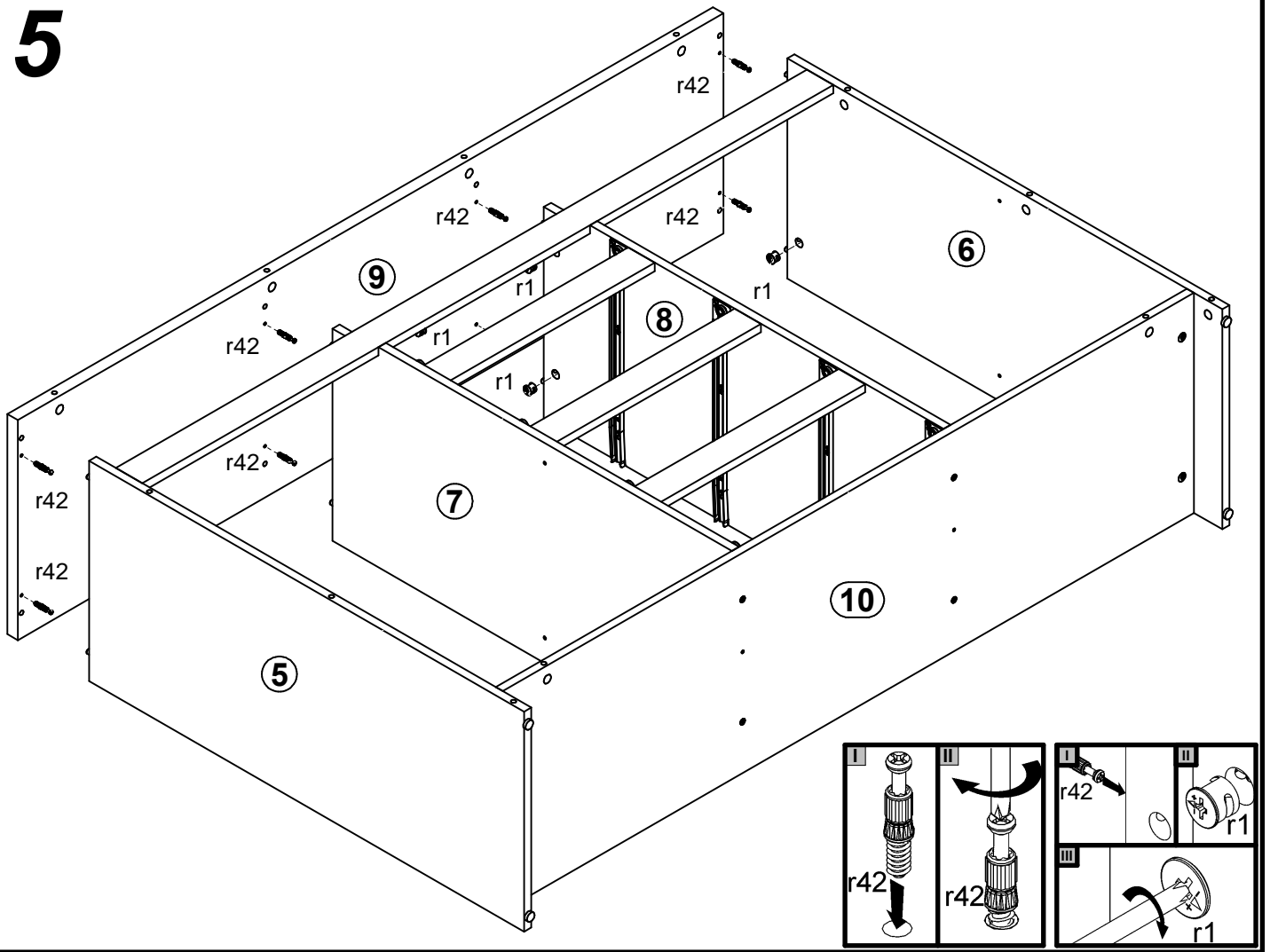

6

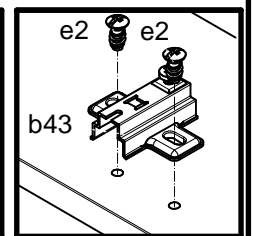
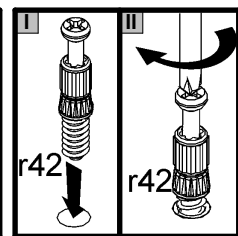
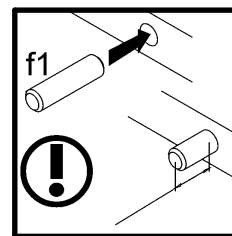
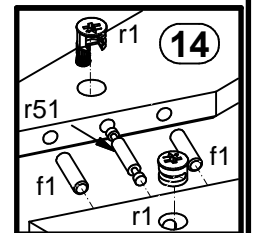
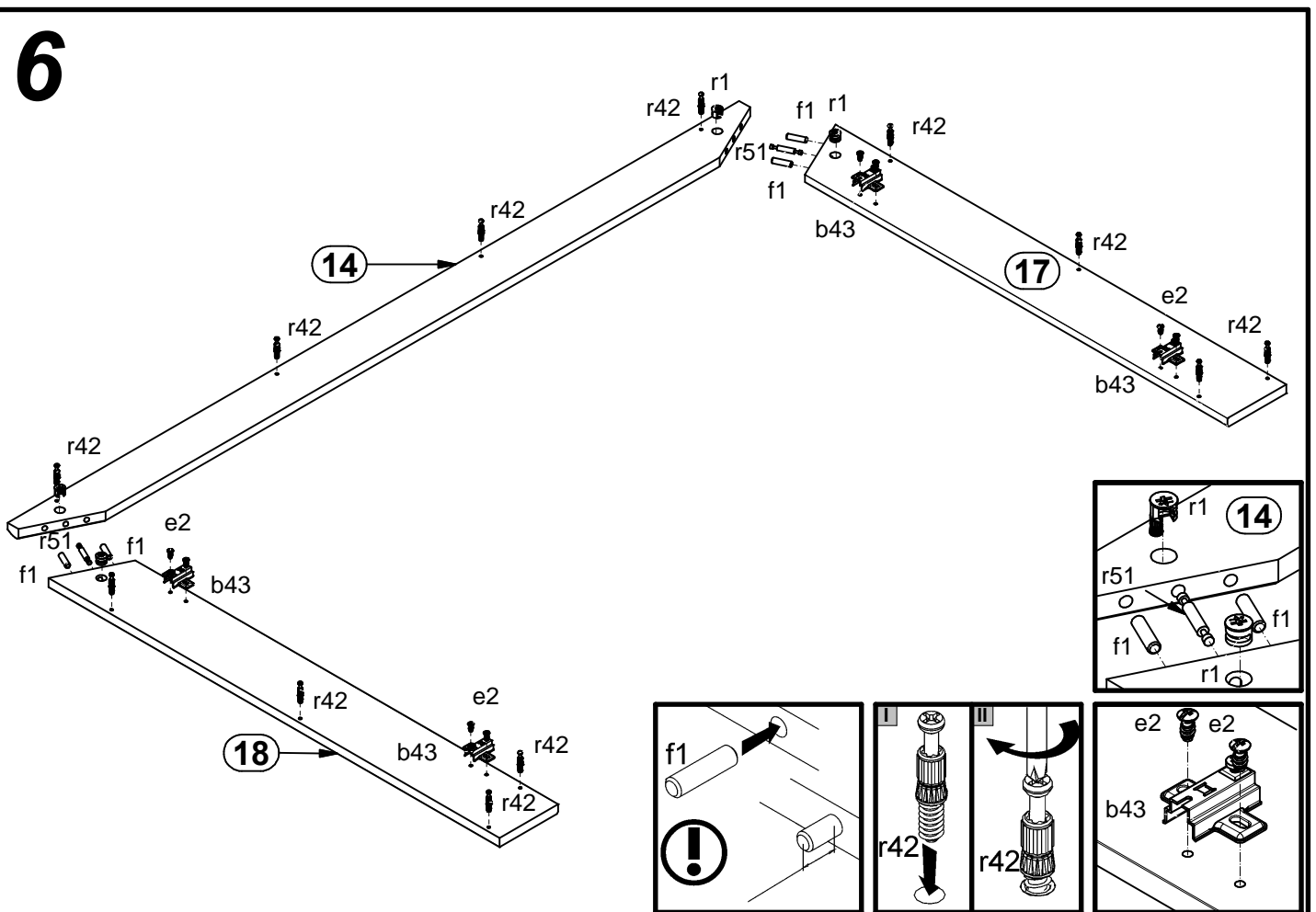

7

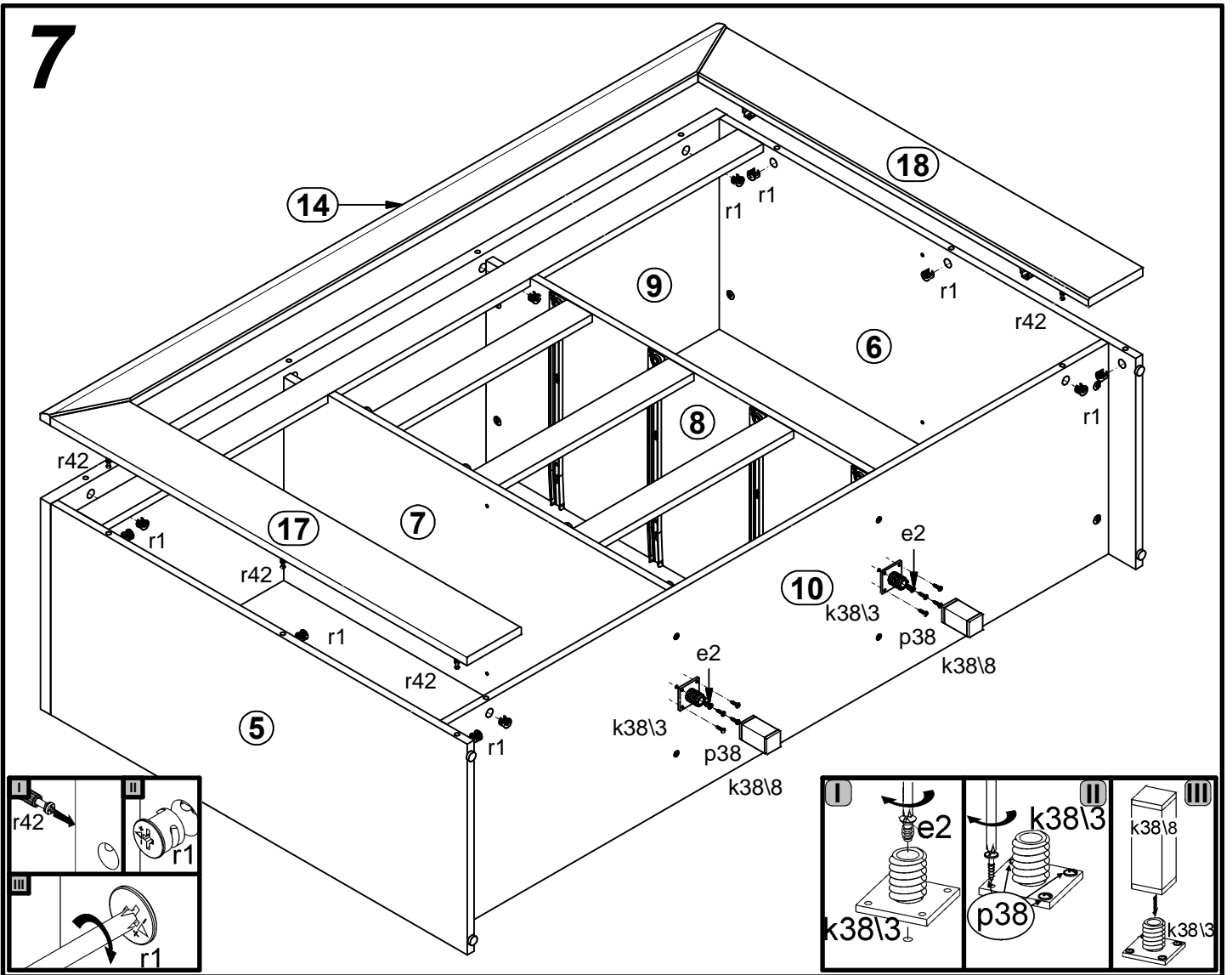

8

