

MATEO

S74-SZF2D/19/9

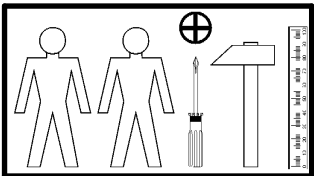
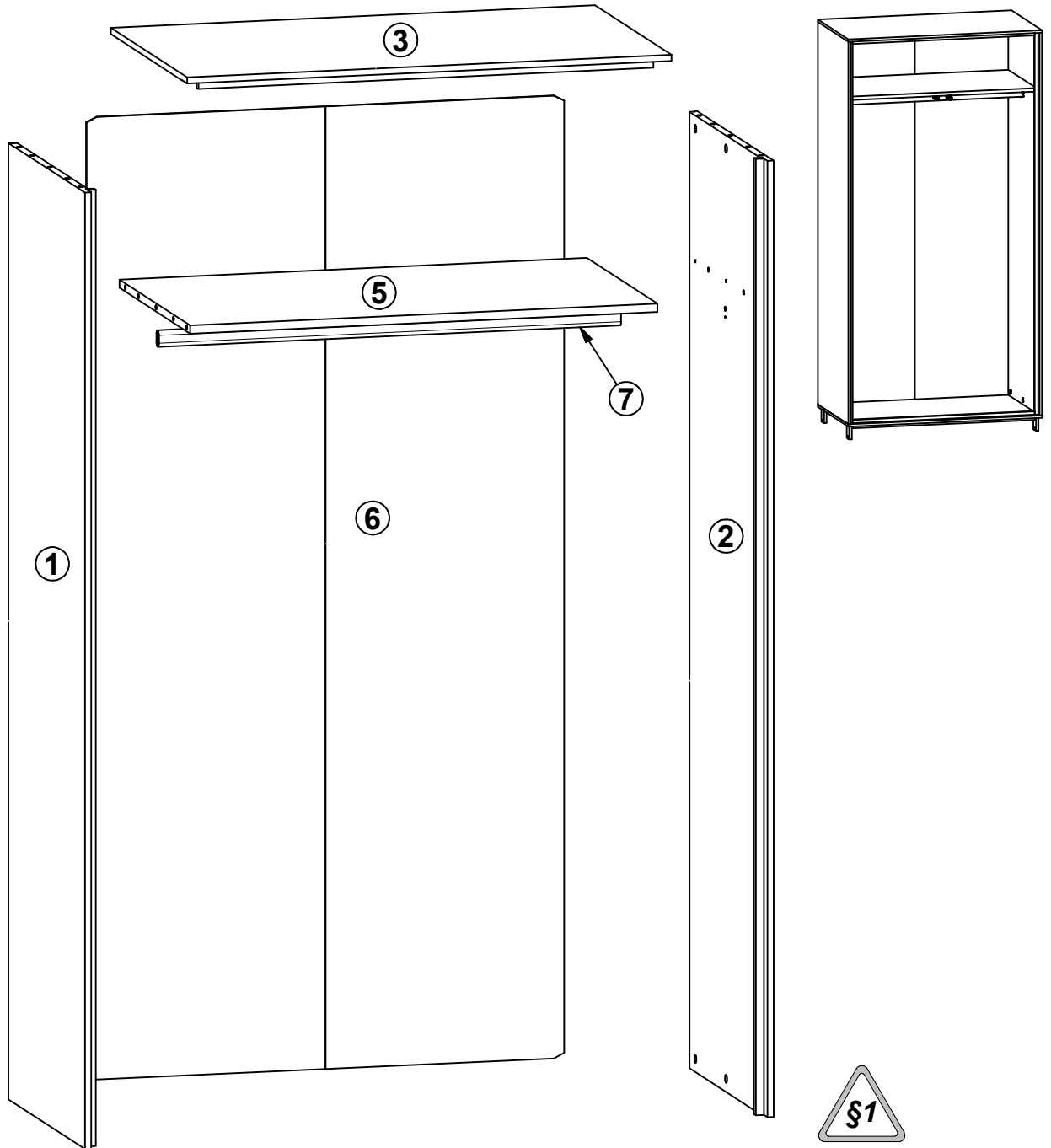

A	B	C	D	
1	S74-108	1833	557	1/3
2	S74-118	1833	557	1/3
3	S74-204	945	558	2/3
4	S74-216	945	558	2/3
5	S74-304	912	515	2/3
6	S74-9906	1845	933	1/3
7	dr-906	906	30	2/3

8x φ5.3x20 mm e17	12x φ8x30 mm f1	2x k65/L	2x k65/P	70x l1	2x n1	2x φ3.5x13 mm p1	6x φ3x12 mm p54	18x φ1.5x12mm #16 r1
18x r16	18x ø16 s2	2x z23/1	2x z23/2	2x z23/3	1x n26/1	1x φ3.5x16 mm p38		

1  §2

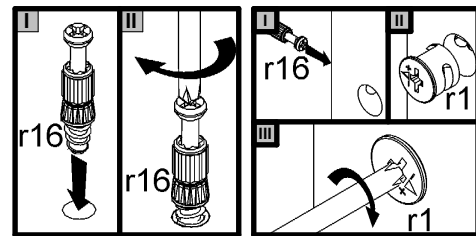
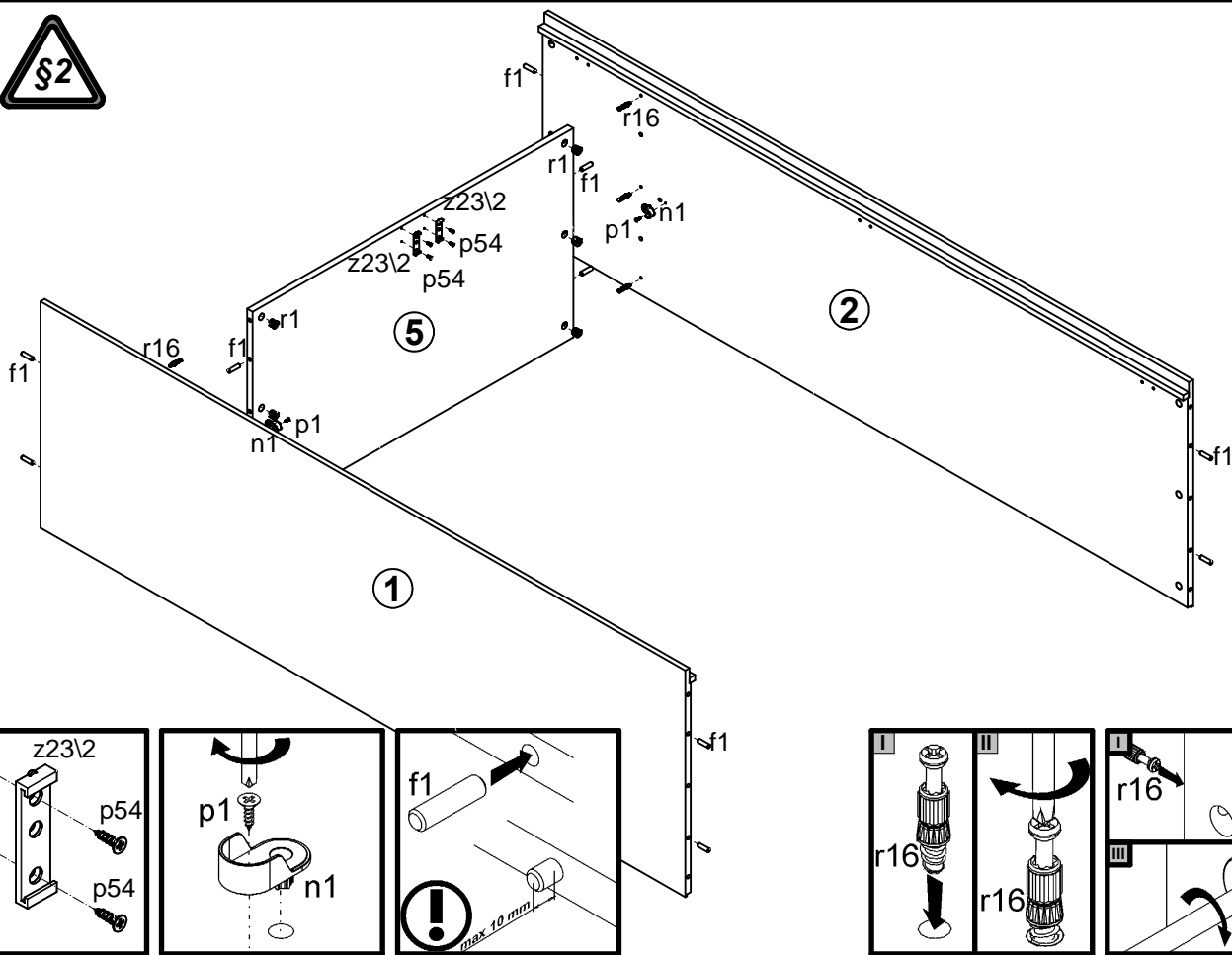

2  §6

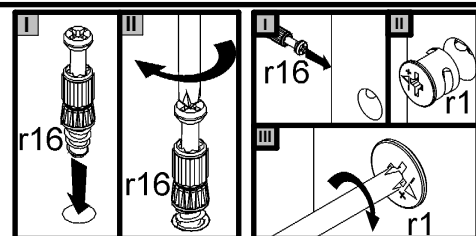
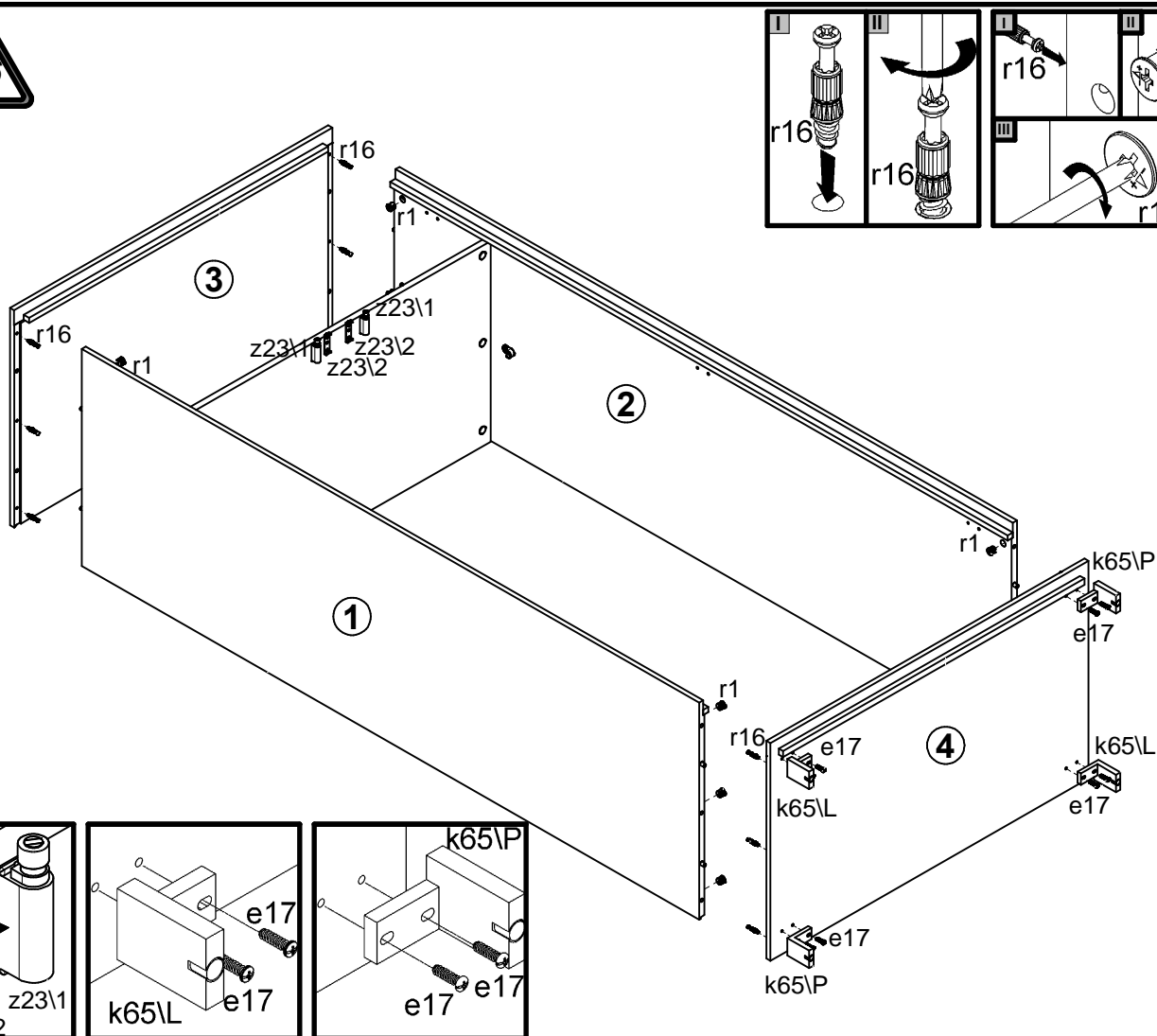

3

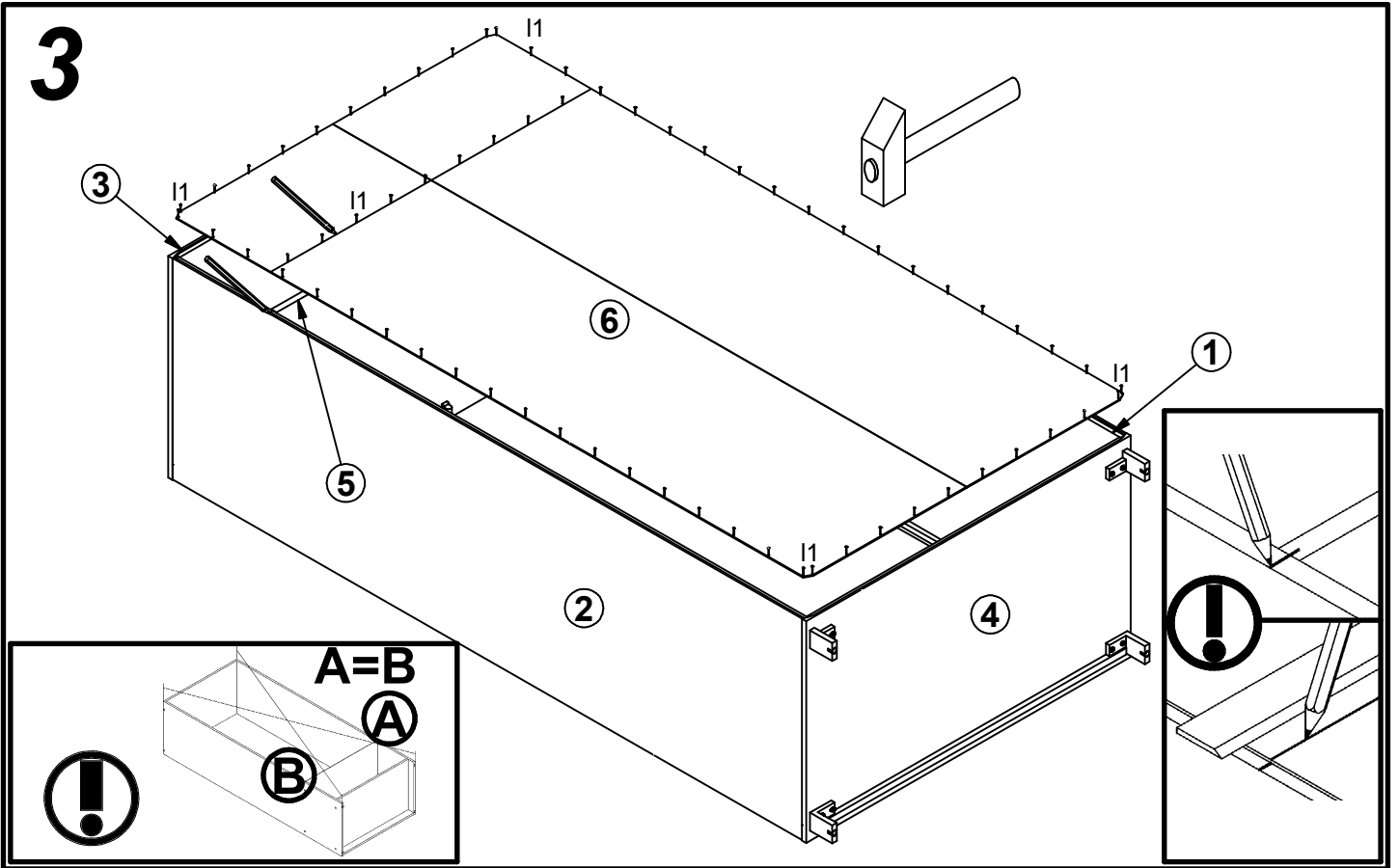

4

