

Podczas montażu
postępować
zgodnie z instrukcją.

While assembling
follow
the instruction.

Montage laut
der Aufbauanleitung
durchführen.

16 kb/19/7

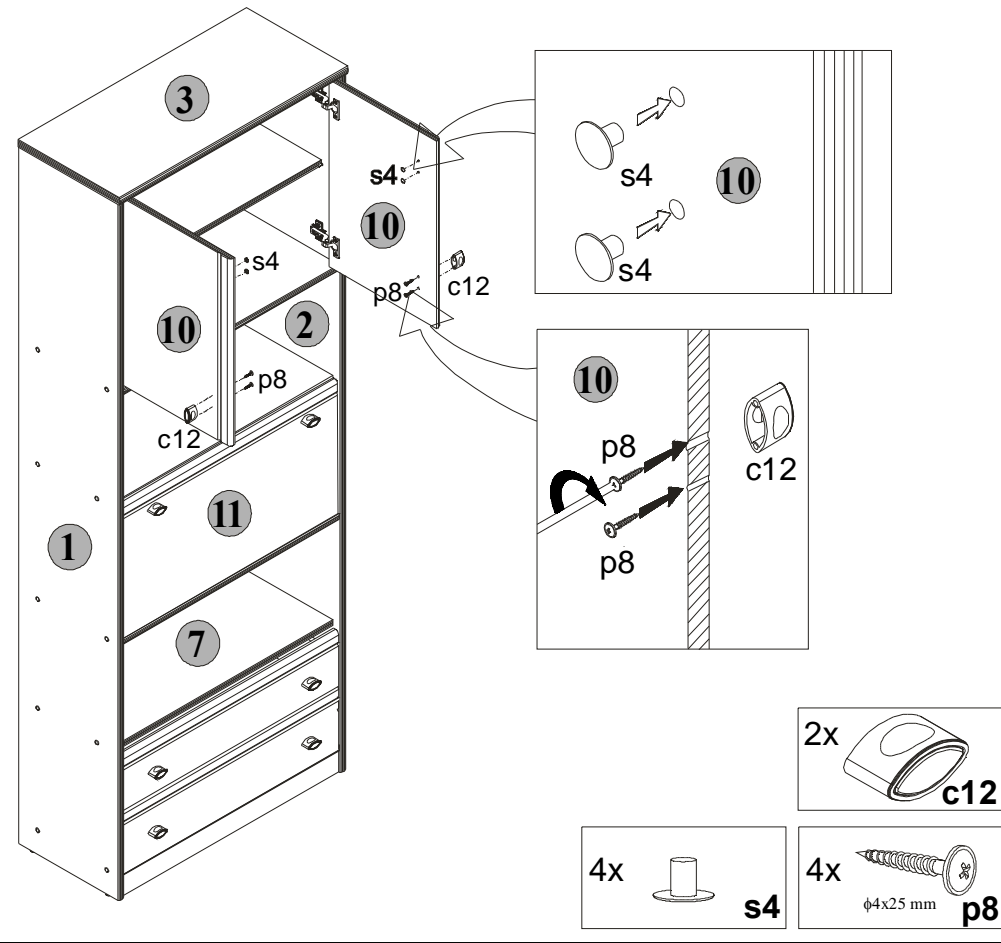

INSTRUKCJA MONTAŻU FITTING-UP INSTRUCTION AUFBAUANLEITUNG



BLACK RED WHITE S.A.
UL. KRZESZOWSKA 63
23-400 BILGORAJ
e-mail: brw@brw.com.pl, http://www.brw.com.pl.

POP SYSTEM

kb/19/7

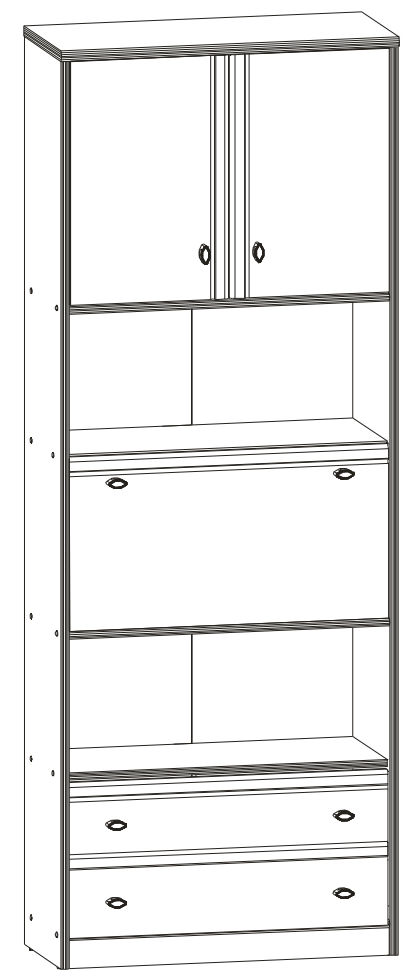

74x33,5x198,5 /cm/

17 kb/19/7

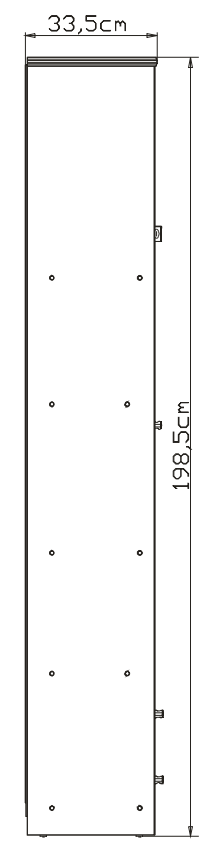
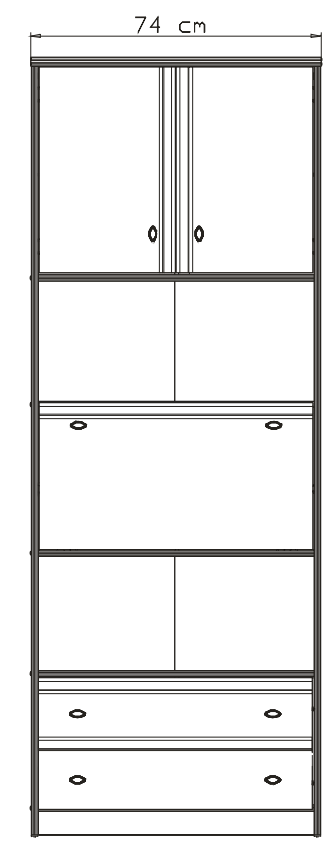
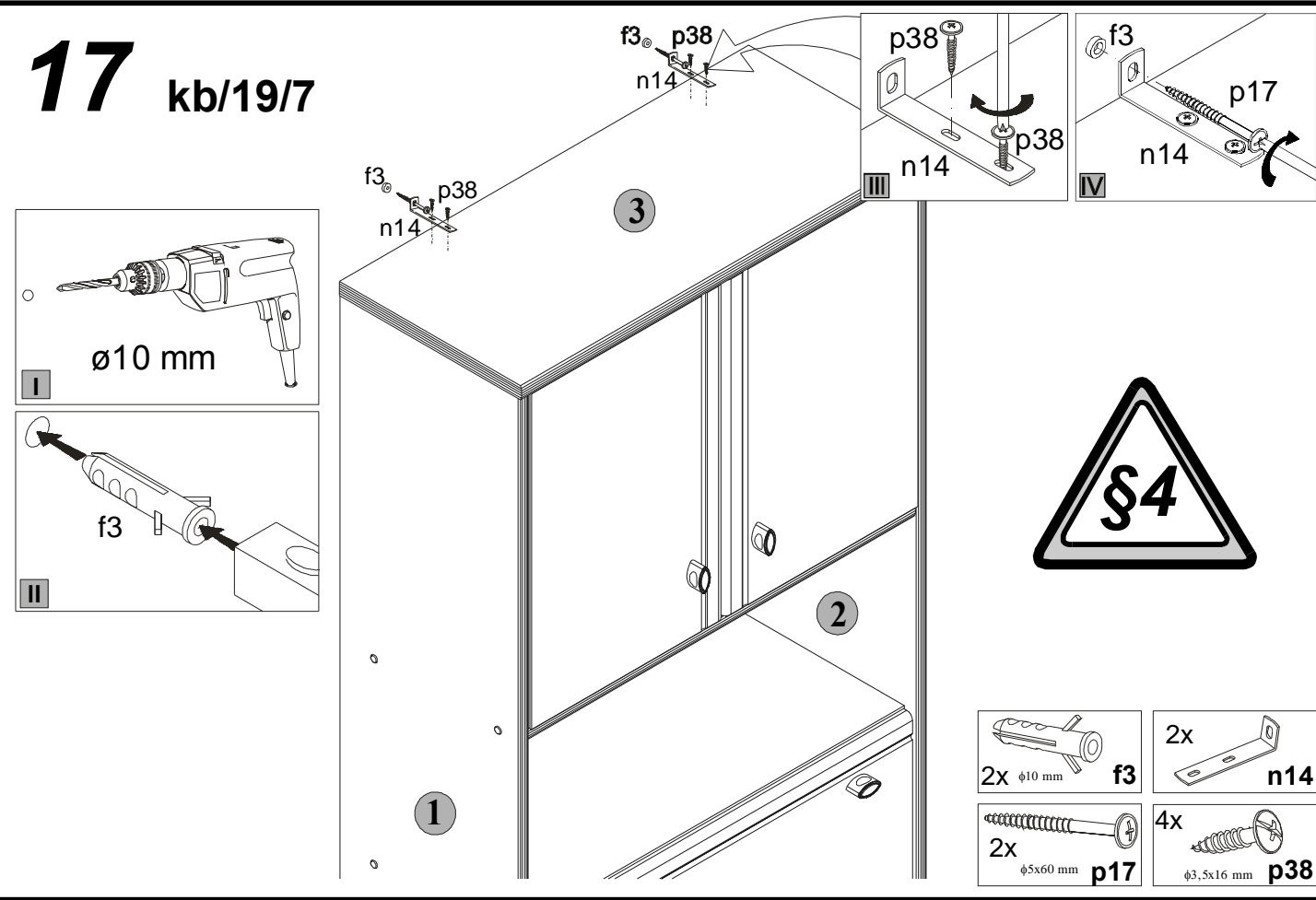

POP SYSTEM

kb/19/7

Symbol elementu Element symbol Elementeszeichen	Wymiary Measurements Ausmaß	Kod Code Kode
1	1958x325	SK1-144
2	1958x325	SK1-145
3	740x330	SK1-207
4	702x321	SK1-306
5	702x321	SK1-387
6	702x300	SK1-388
7	702x300	SK1-331
8	701x290	SK1-323
9	702x60	SK1-402
10	526x348	SK1-022
11	698x375	SK1-033
12	698x185	SK1-002
13	698x150	SK1-003
14	1915x731	SK1-9901
15	681x280	SK1-910
16	1255x120	SK1-504

Paczki:/Packages:/Paketen:

Korpus1 /Body 1/Möbelkorps 1
 Korpus 2/Body 2/Möbelkorps 2
 Fronty /Fronts /Möbelfronten
 Akcesoria/Accessories/Zubehör

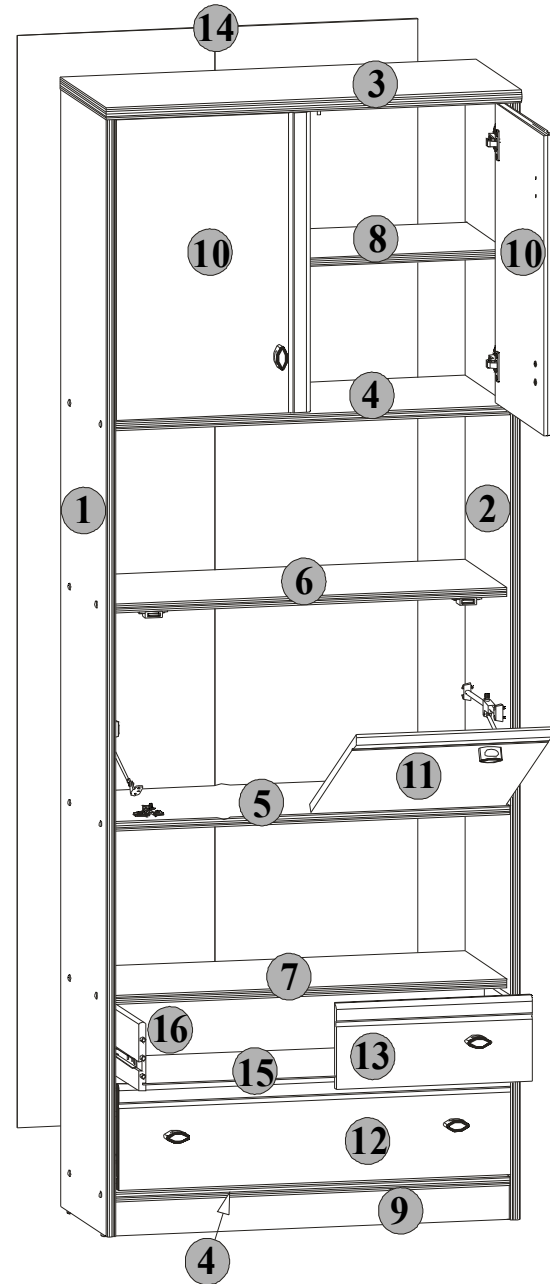

Akcesoria/Accessories/Zubehör

6x a1	6x b1	8x c12	20x e1 φ7x50 mm	2x f3 φ10 mm	4x d1 φ5x17 mm	2x d4 φ6x15 mm
40x f1 φ8x30 mm	4x j2 M4x9 mm	4x k1	50x l1	1x m1 ^L	1x m1 ^P	2x n2
2x n3	2x n14 81x21x15/1.5mm	18x p1 φ3.5x13 mm	4x p5 φ3.5x13 mm	16x p8 φ4x25 mm	4x p15 φ2.5x13 mm	2x p17 φ5x60 mm
2x p25 φ3.5x16 mm	2x p35 φ3.5x10 mm	4x p38 φ3.5x16 mm	8x p50 φ2.9x24 mm	4x r1 φ15 #16	4x r6 φ8/M6x11 mm	4x r16
20x s1	4x s2	4x s4 φ5	2x t2 280 mm	4x w1 185 mm	1x y1 GLUE	1x z1

Podczas montażu
postępować
zgodnie z instrukcją.

While assembling
follow
the instruction.

Montage laut
der Aufbauanleitung
durchführen.

14 kb/19/7

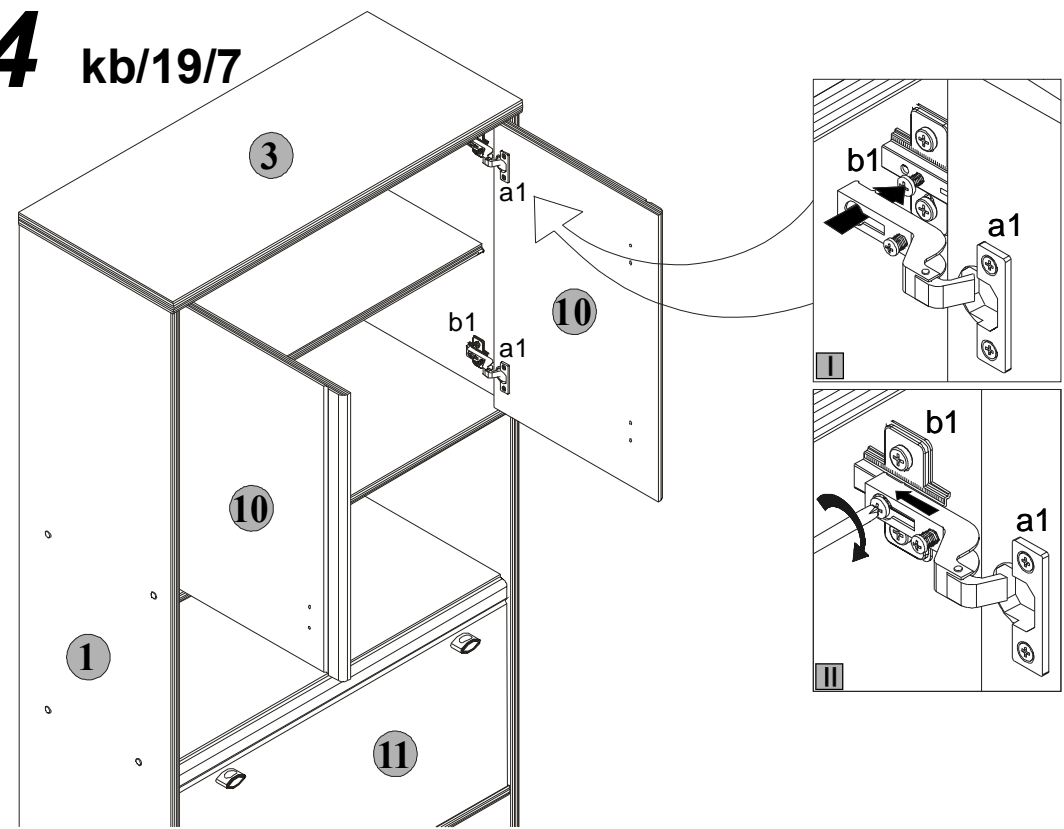

15 kb/19/7

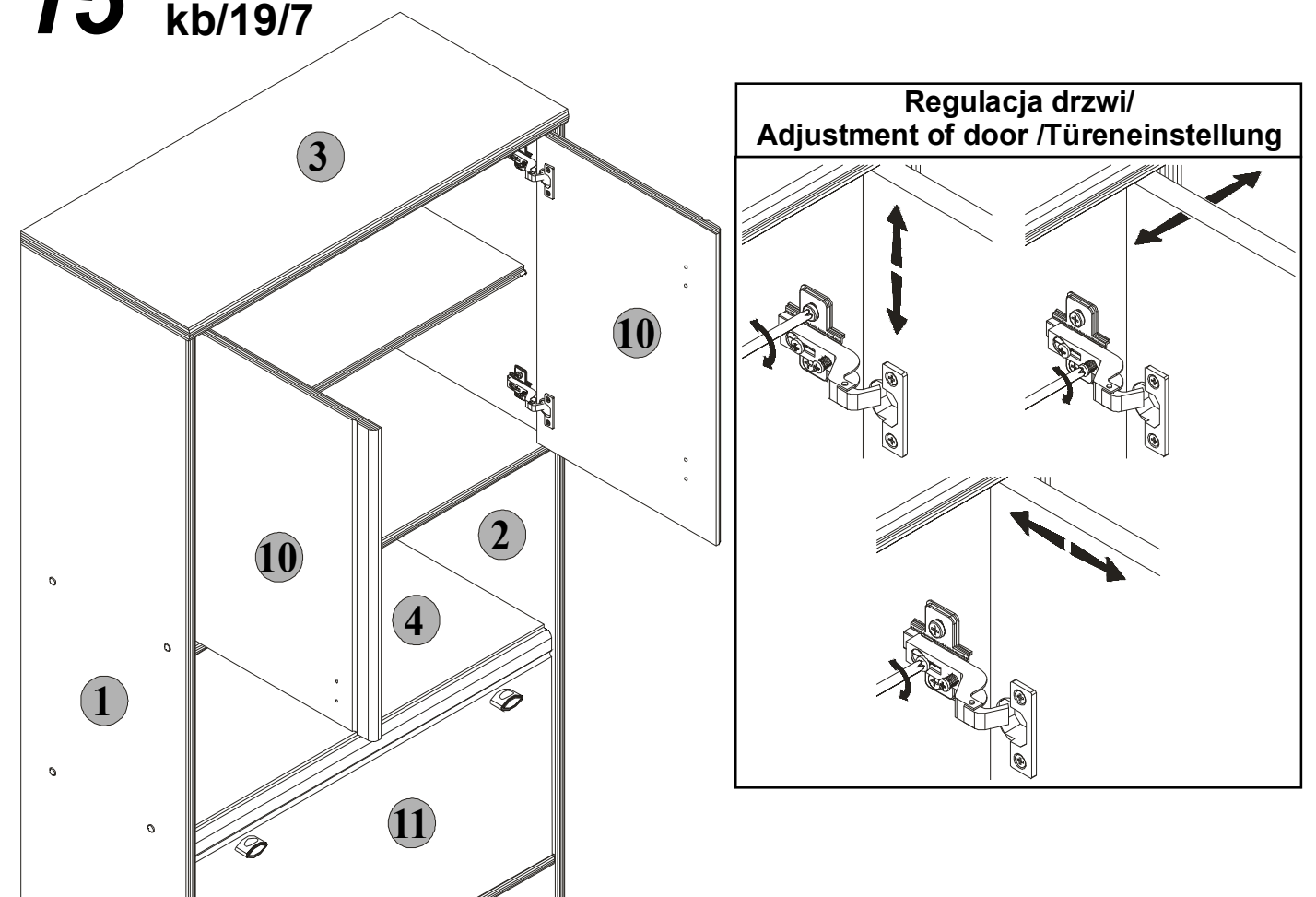

Podczas montażu
postępować
zgodnie z instrukcją.

While assembling
follow
the instruction.

Montage laut
der Aufbauanleitung
durchführen.

12 kb/19/7

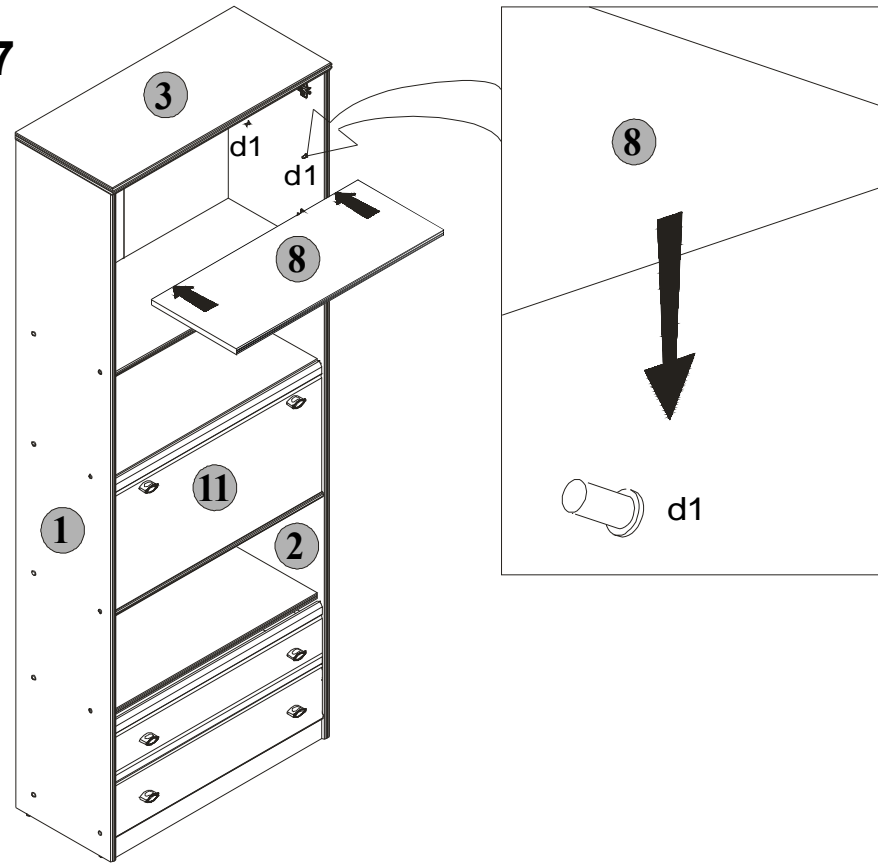

13 kb/19/7



Uwaga! Podczas wykonywania tej czynności należy zwrócić szczególną uwagę, ponieważ zachodzi niebezpieczeństwo skażenia się, jak również uszkodzenia frontu!

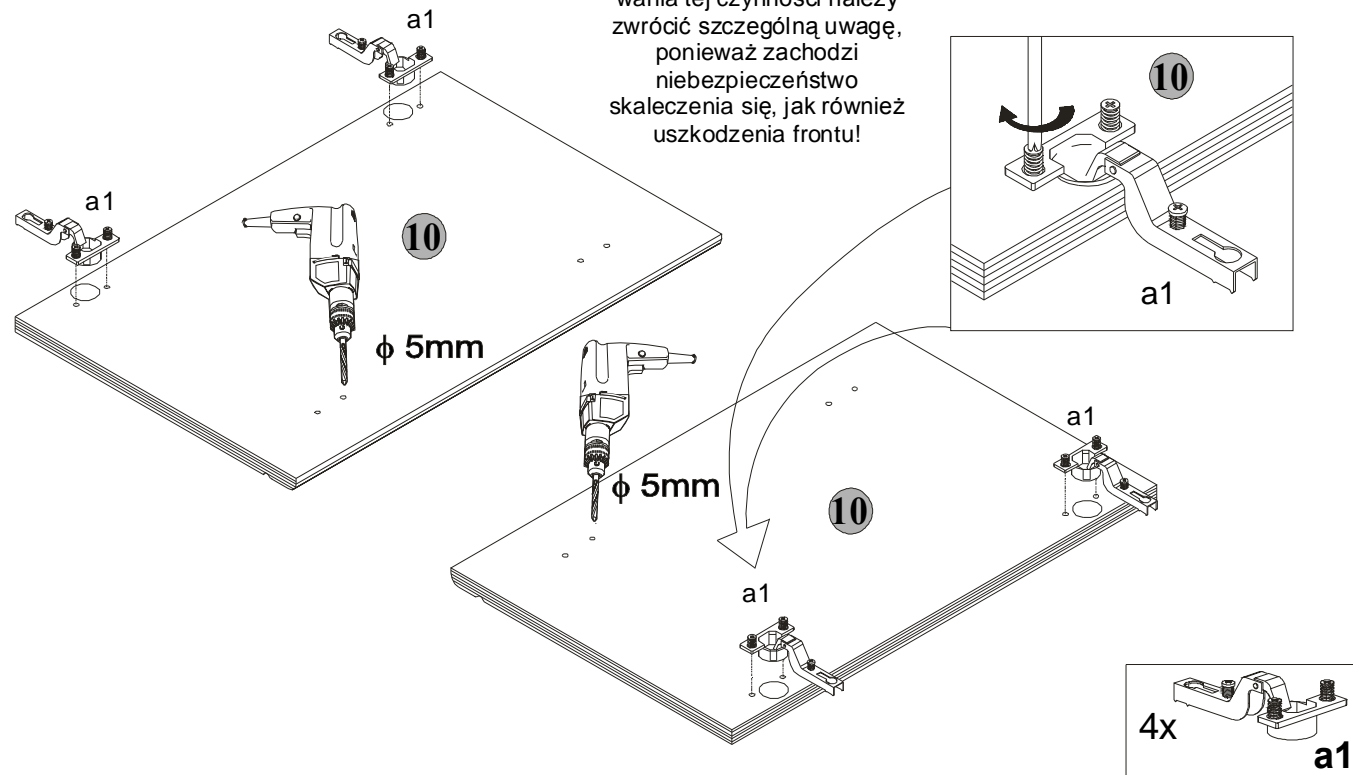

Podczas montażu
postępować
zgodnie z instrukcją.

While assembling
follow
the instruction.

Montage laut
der Aufbauanleitung
durchführen.

Korpus 1/Body 1/Möbelkorps 1

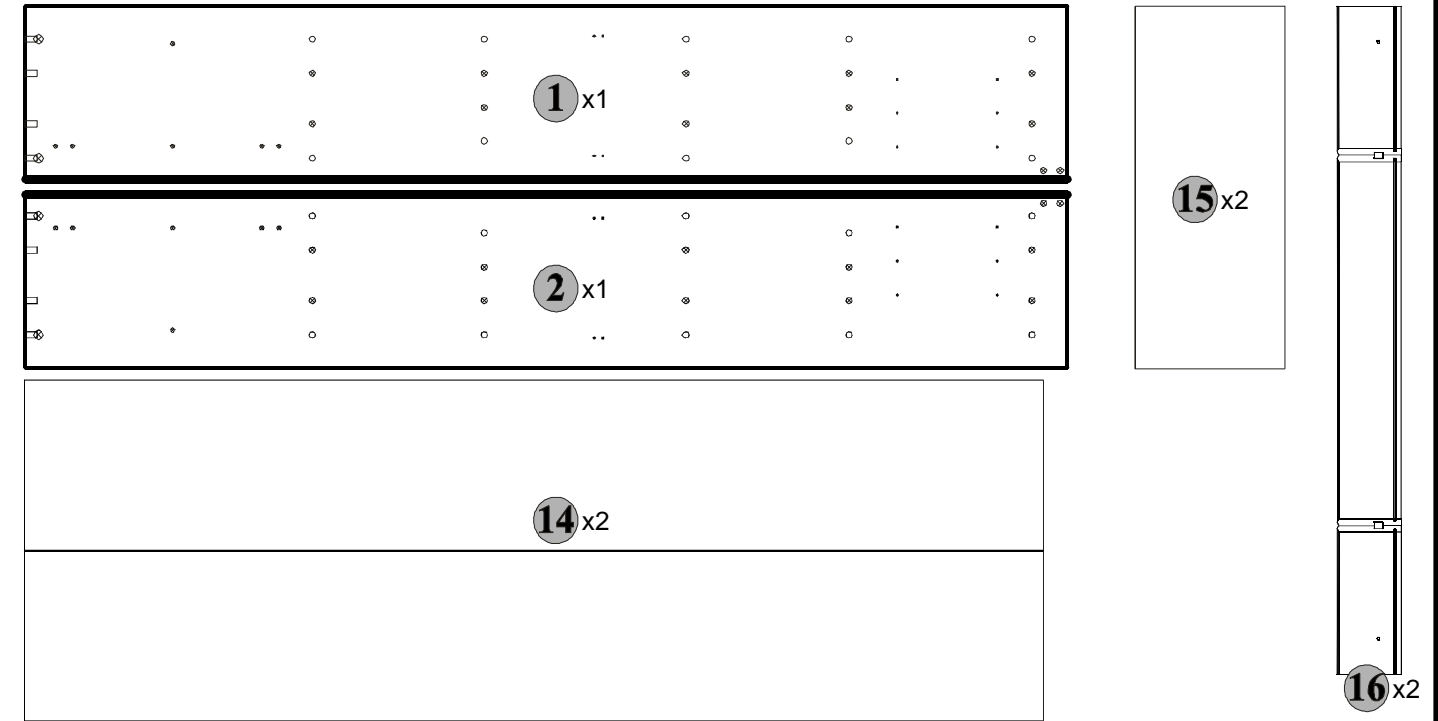

Korpus 2/Body 2/Möbelkorps 2

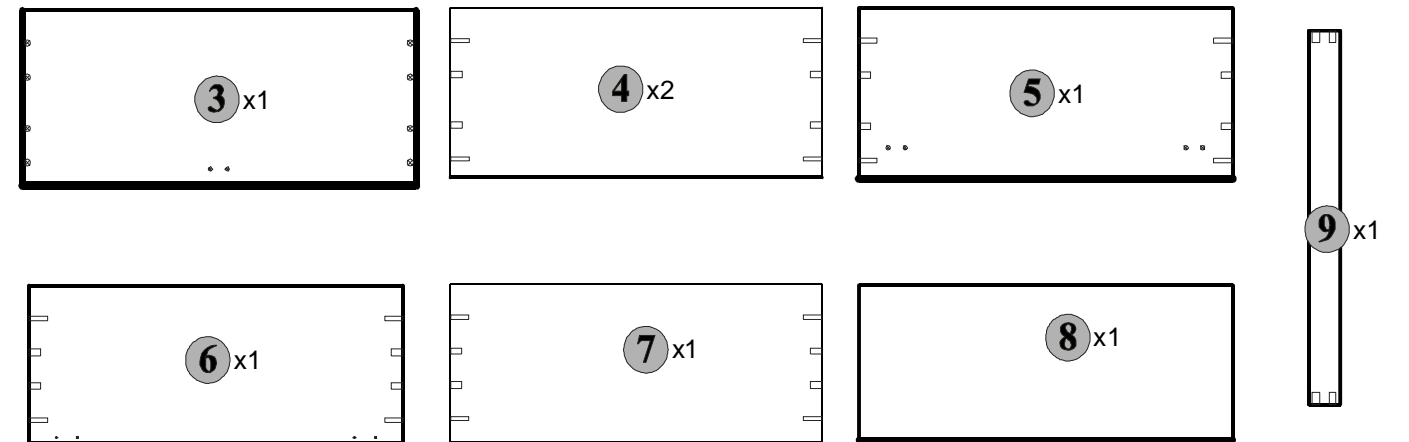

Fronty /Fronts /Möbelfronten

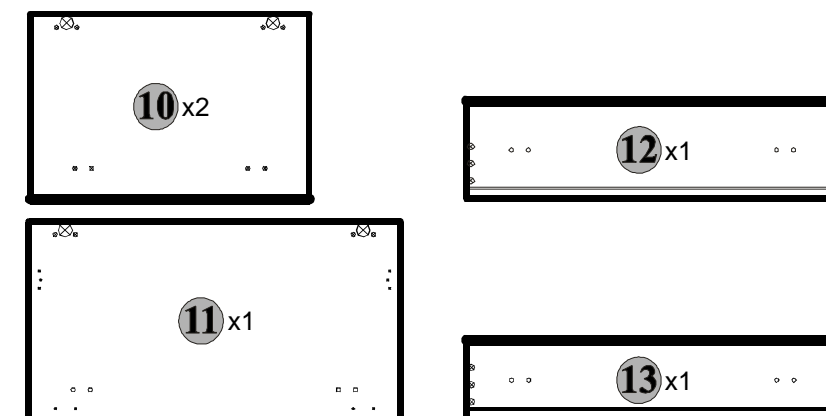

Do montażu potrzebne są:
You need for fitting-up:
Zur Montage werden Sie brauchen:

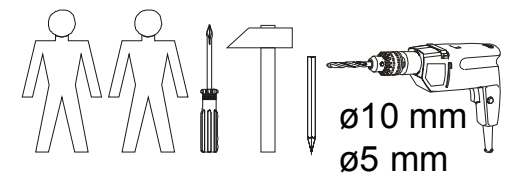

Podczas montażu
postępować
zgodnie z instrukcją.

While assembling
follow
the instruction.

Montage laut
der Aufbauanleitung
durchführen.

Podczas montażu
postępować
zgodnie z instrukcją.

While assembling
follow
the instruction.

Montage laut
der Aufbauanleitung
durchführen.

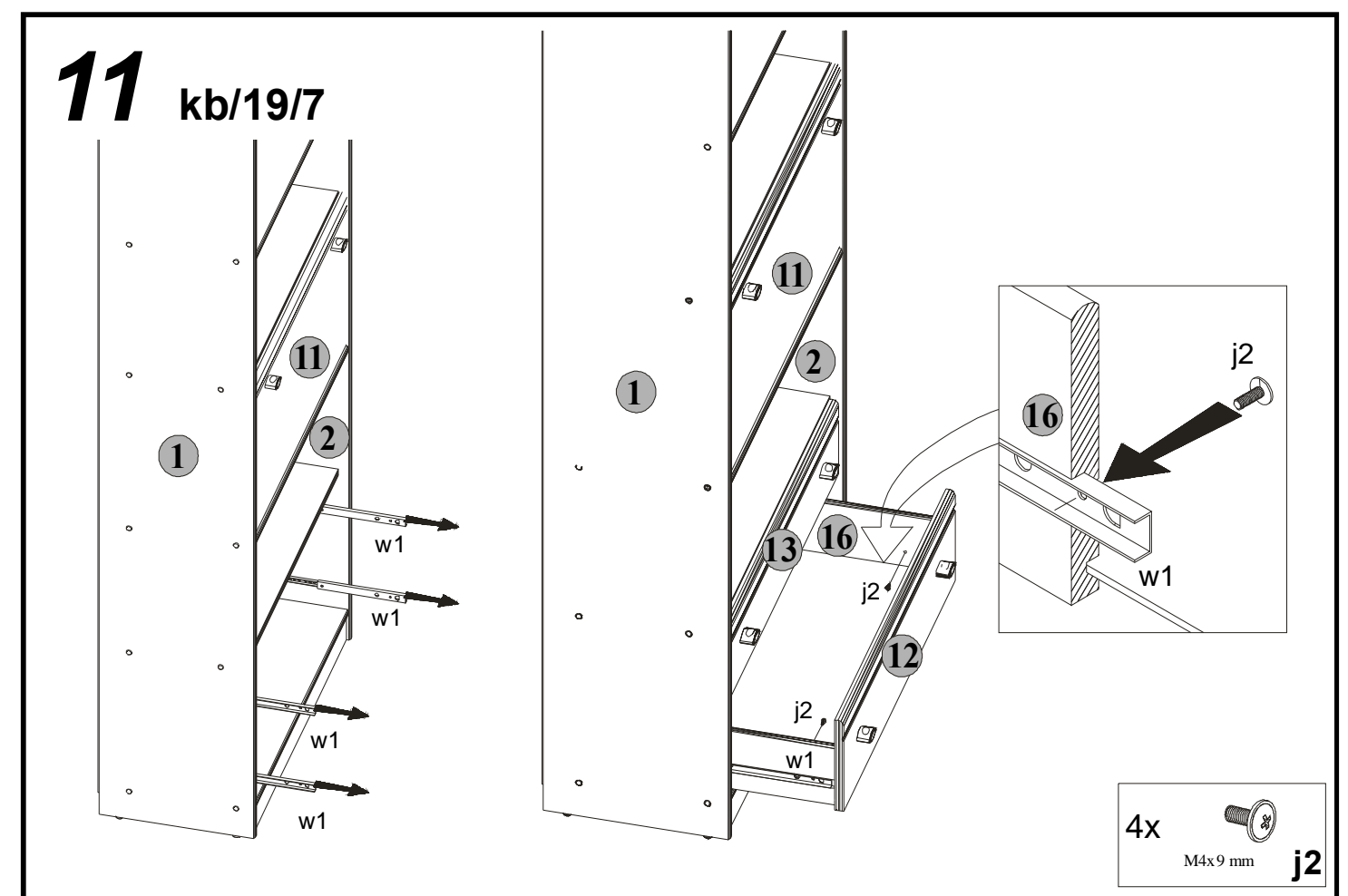
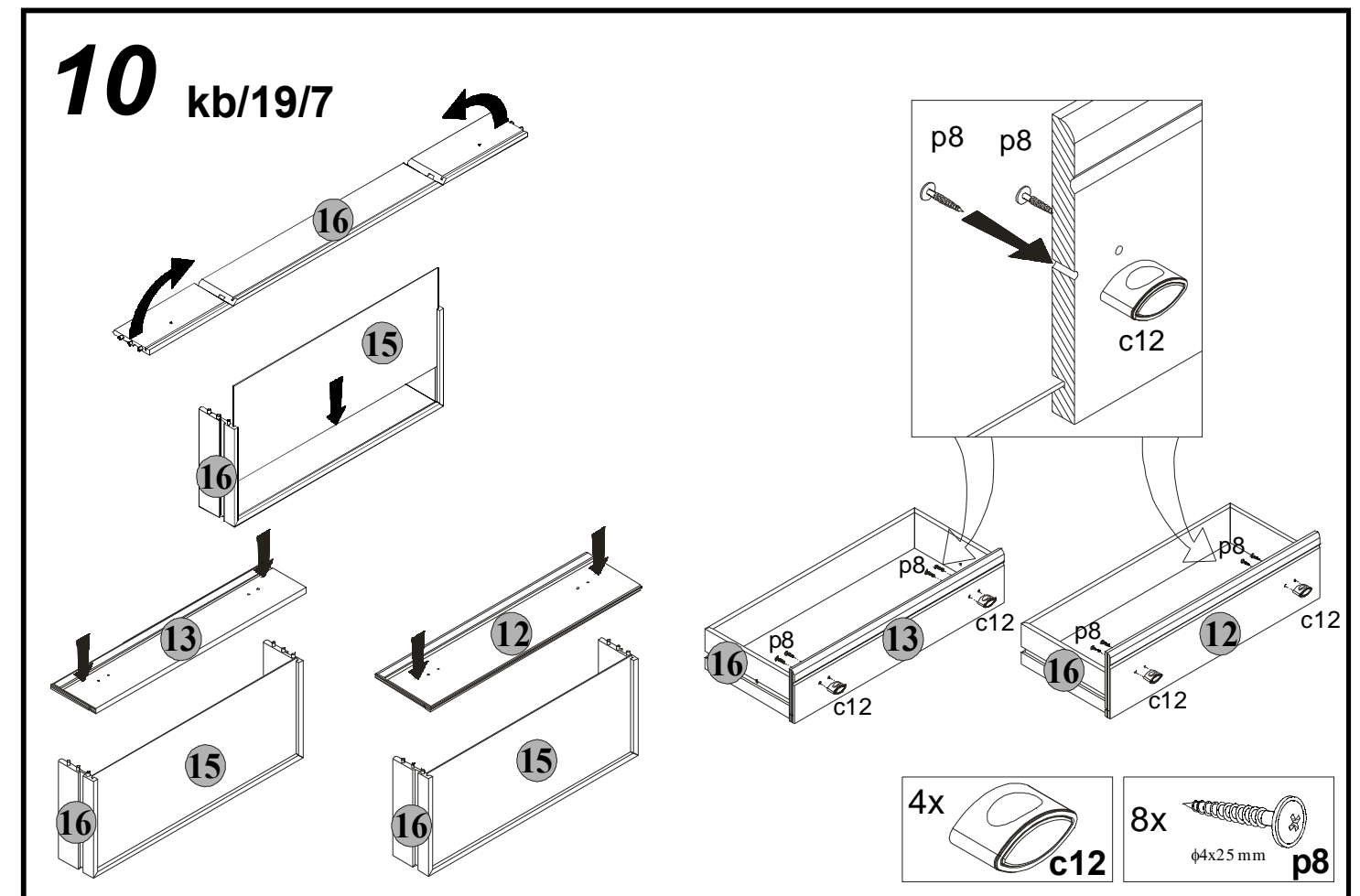
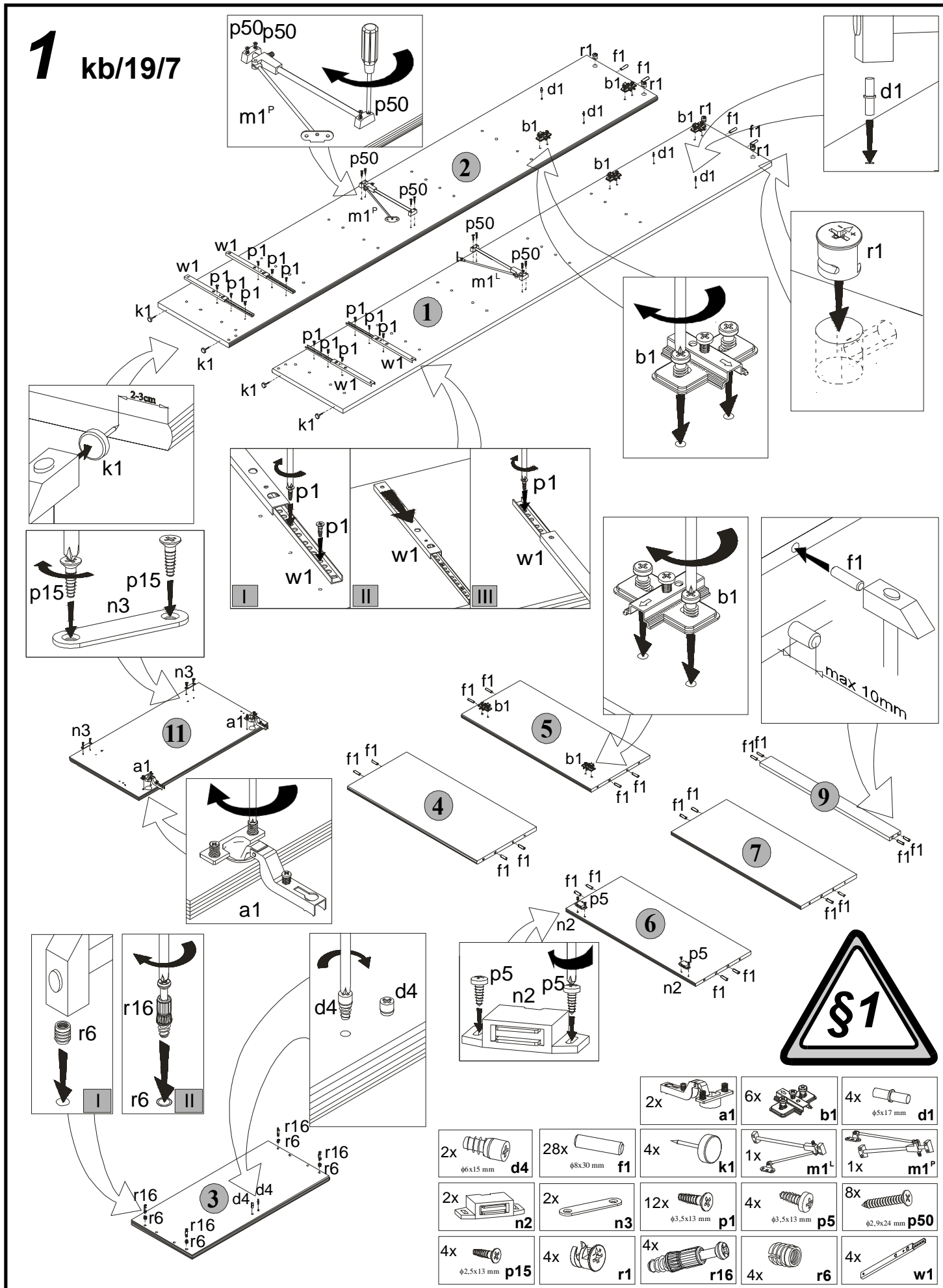

Podczas montażu
postępować
zgodnie z instrukcją.

While assembling
follow
the instruction.

Montage laut
der Aufbauanleitung
durchführen.

8 kb/19/7

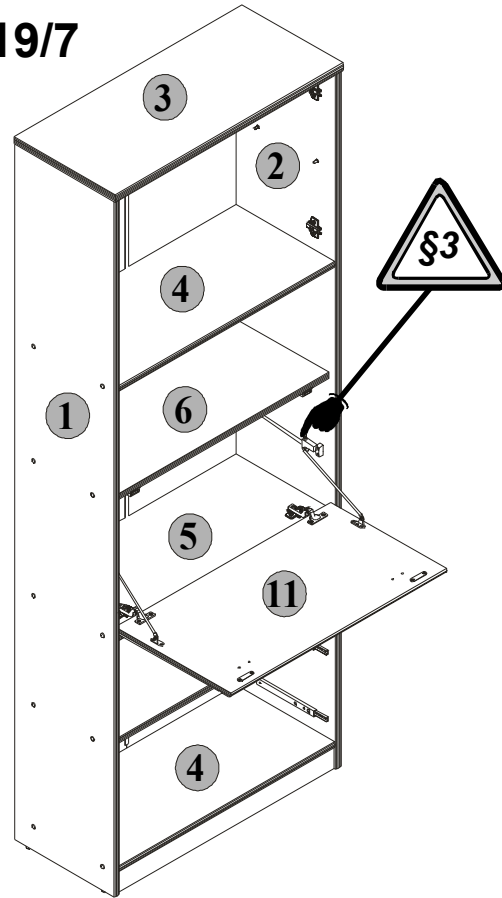

Regulacja drzwi/ Adjustment of door /Türeneinstellung

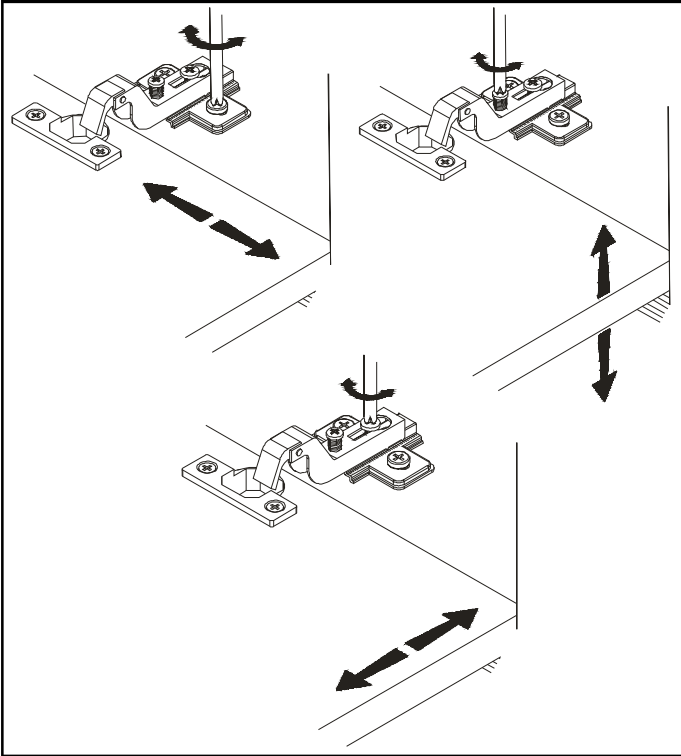

2 kb/19/7

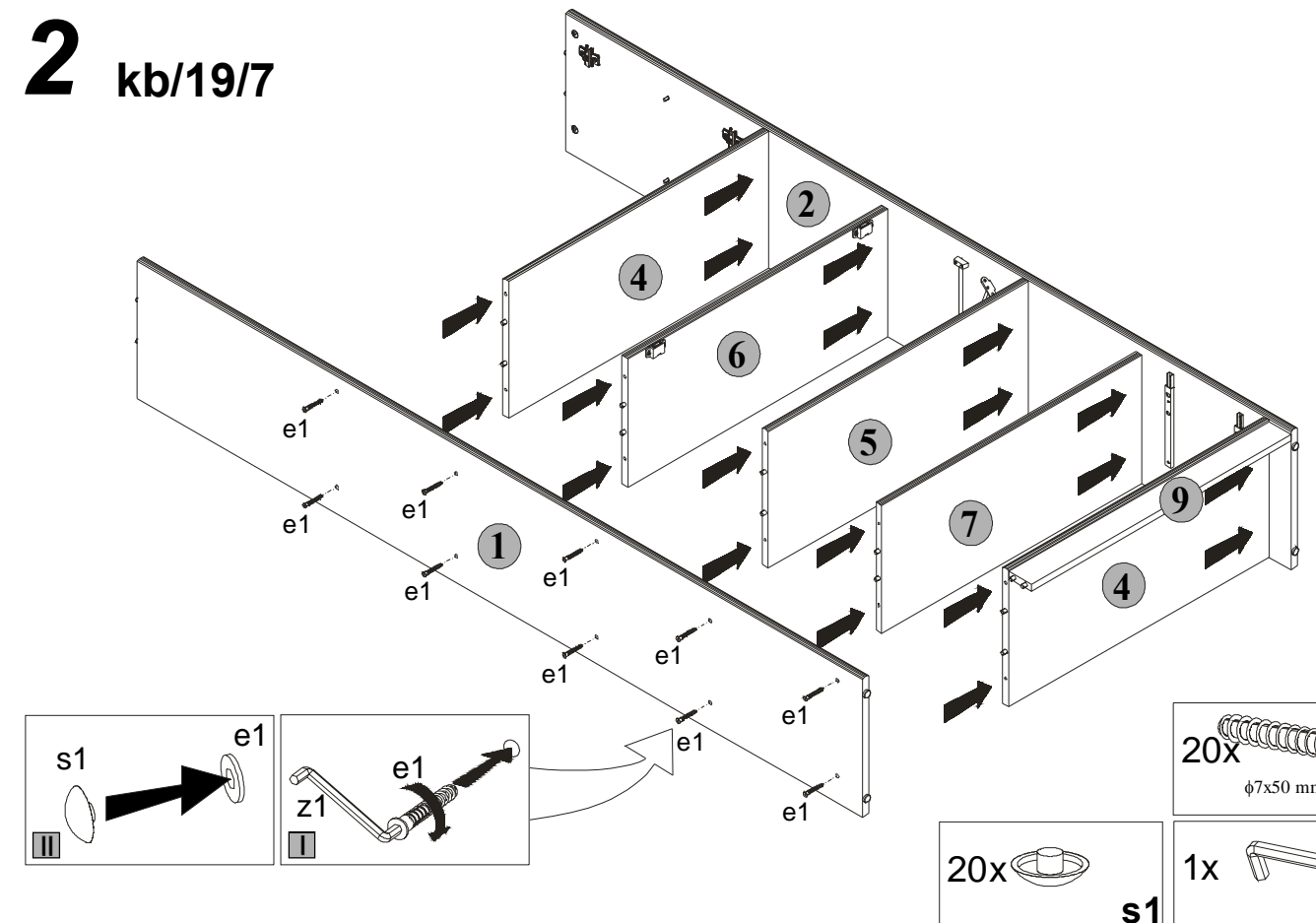

9 kb/19/7

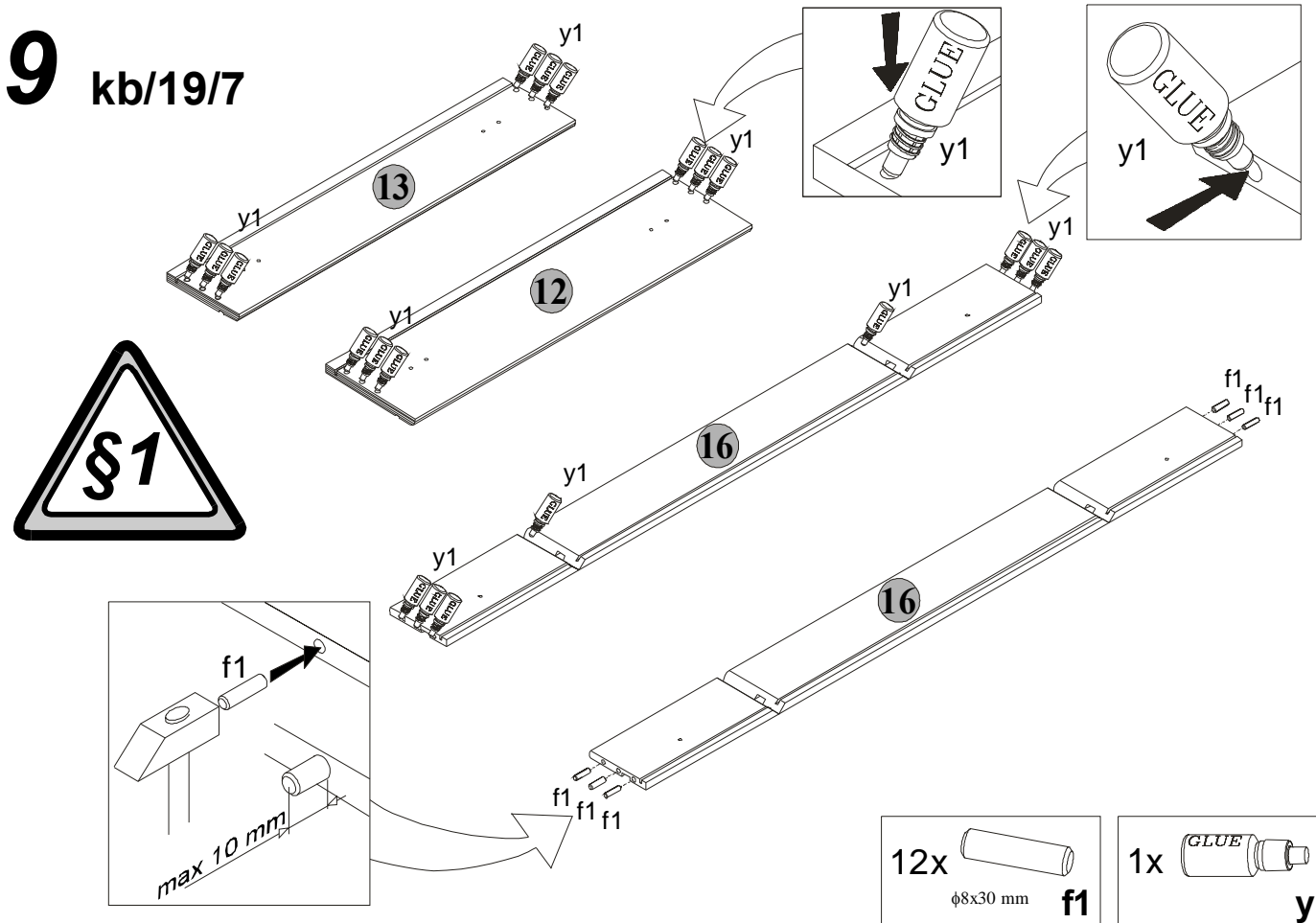

3 kb/19/7

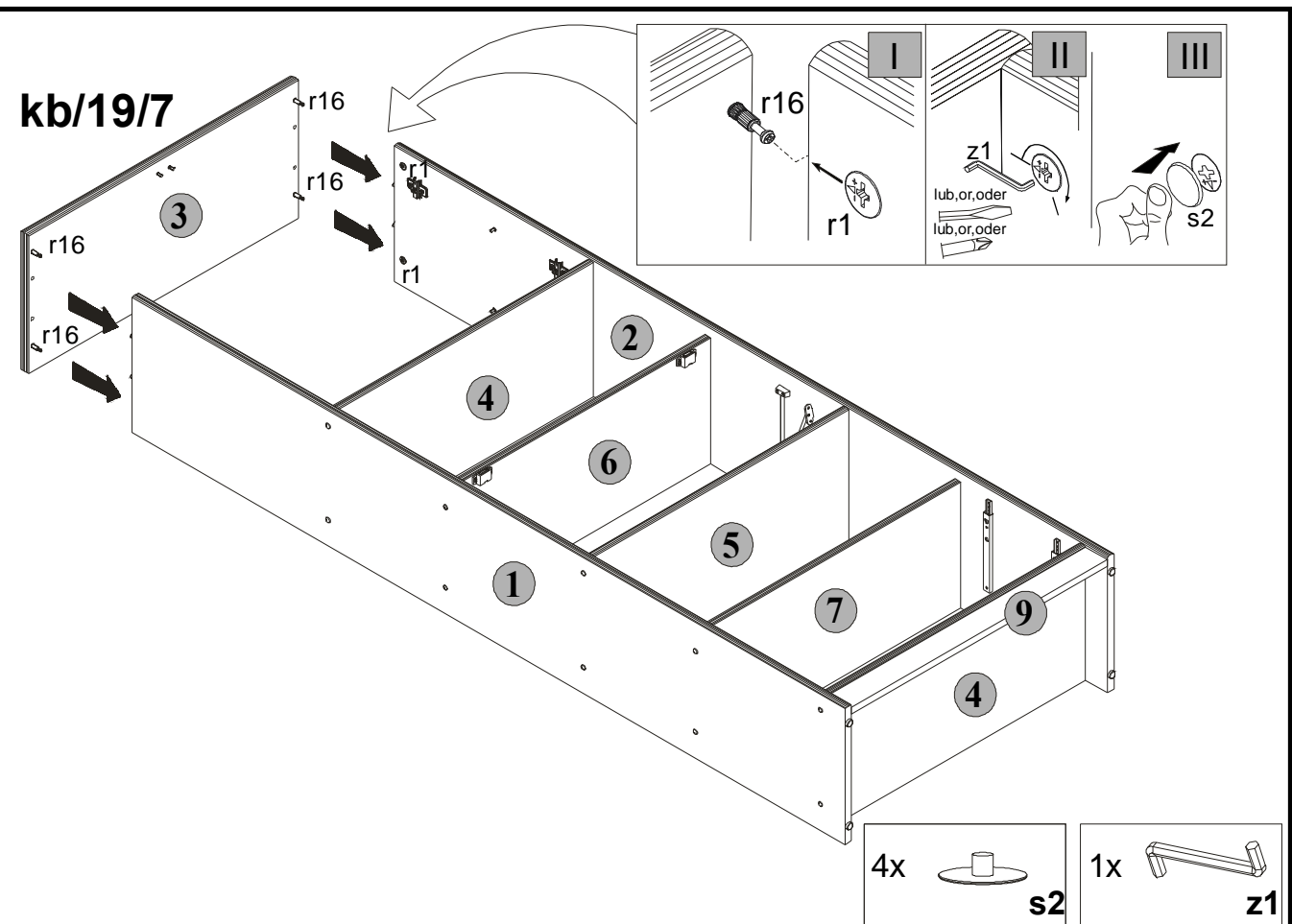

Podczas montażu
postępować
zgodnie z instrukcją.

While assembling
follow
the instruction.

Montage laut
der Aufbauanleitung
durchführen.

4 kb/19/7

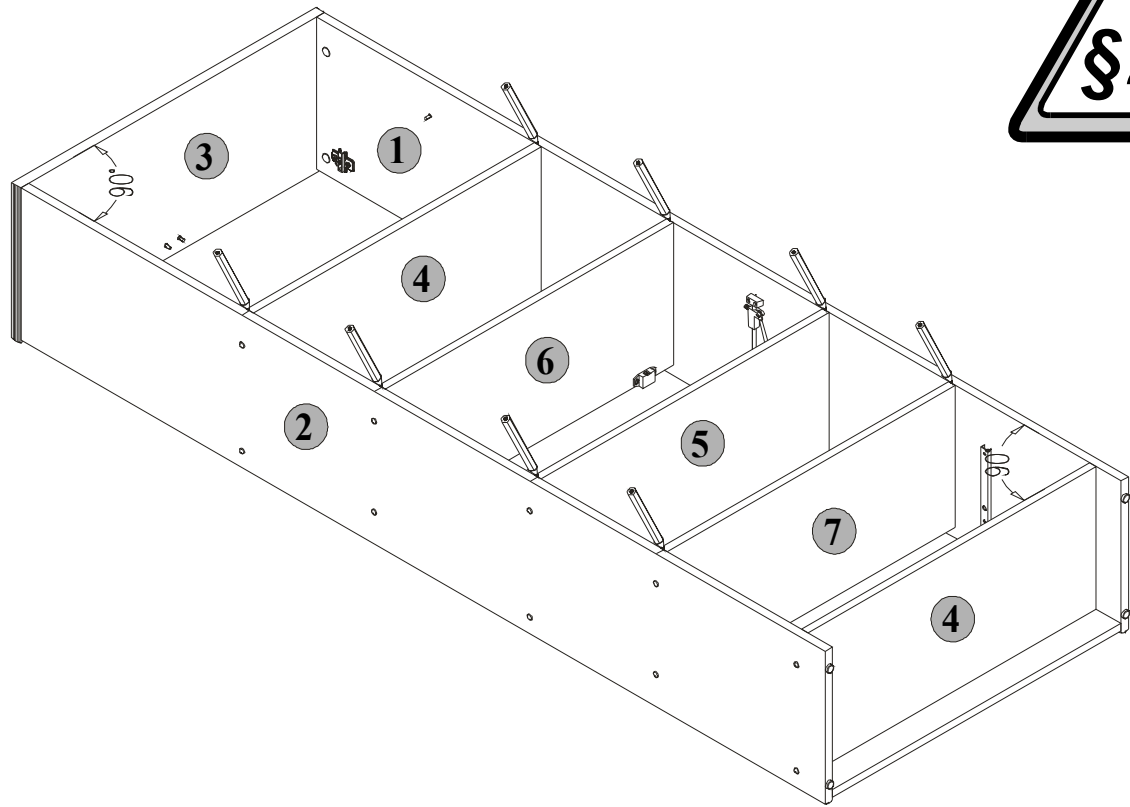

6 kb/19/7

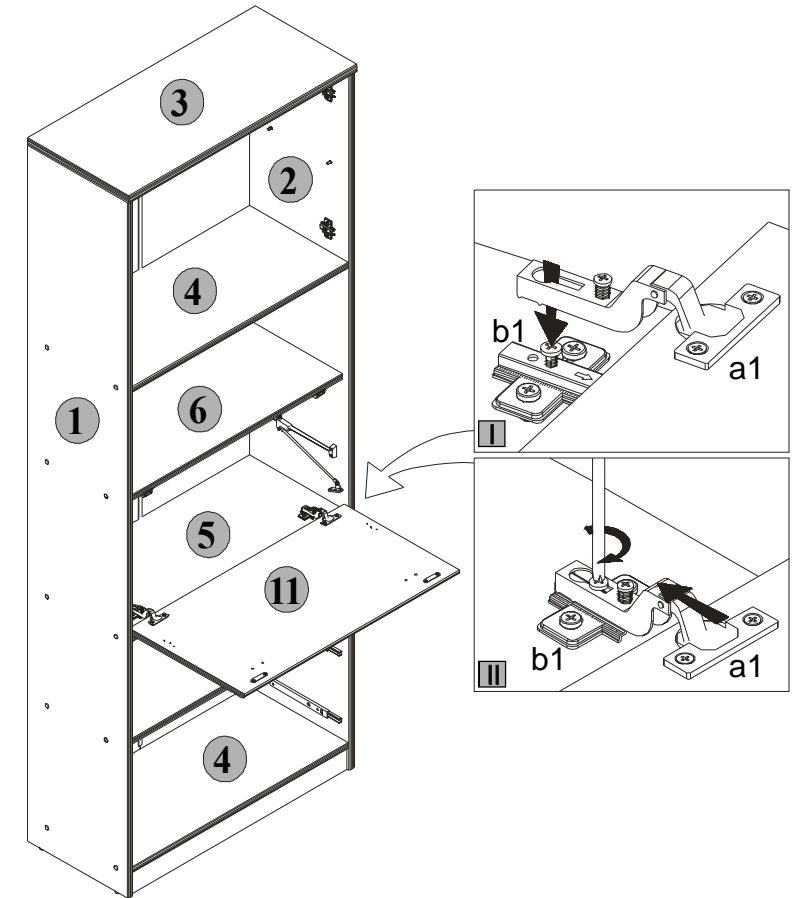

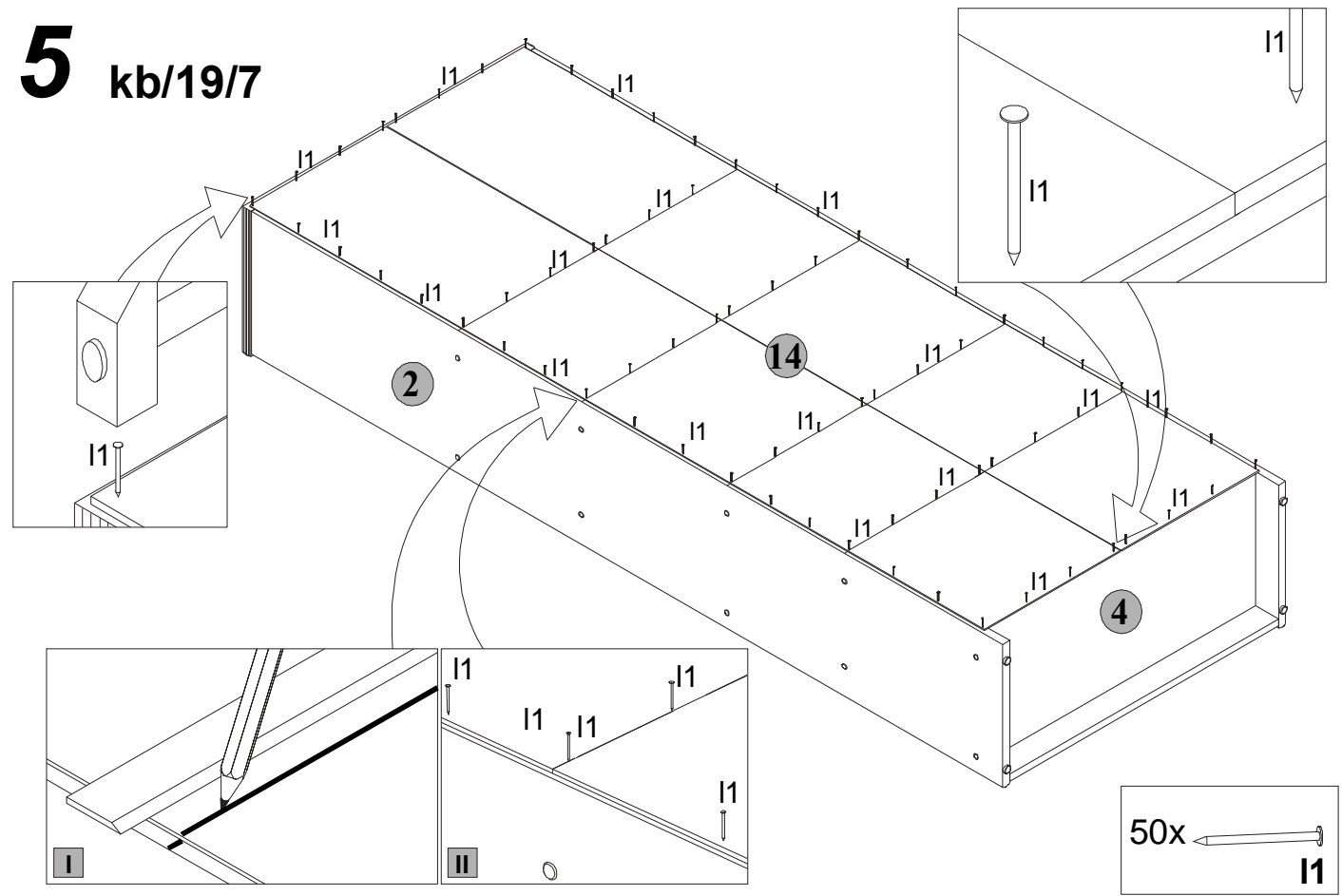

5 kb/19/7

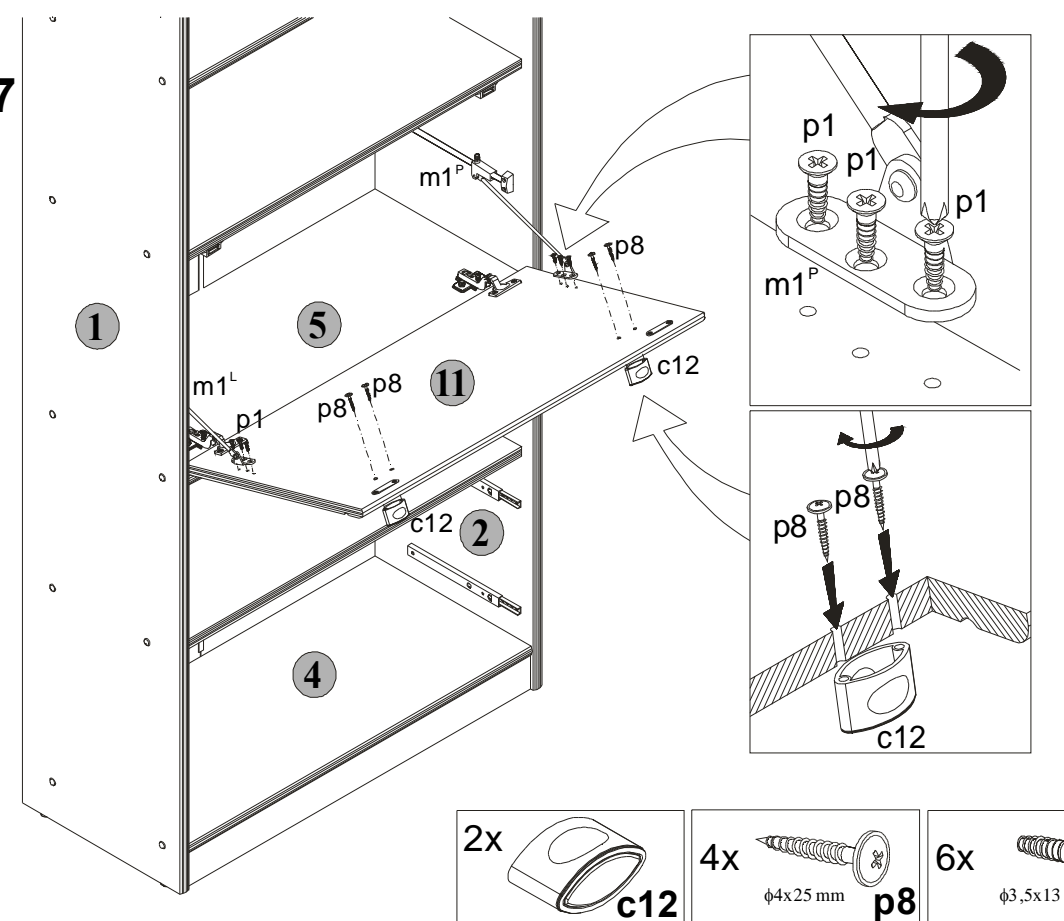

50x  l1

7 kb/19/7

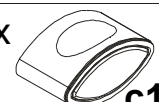
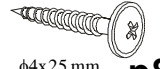

2x  c12 4x  p8 φ4x25 mm 6x  p1 φ3,5x13 mm