

Podczas montażu
postępować
zgodnie z instrukcją.

While assembling
follow
the instruction.

Montage laut
der Aufbauanleitung
durchführen.

12 kbiu/8/12



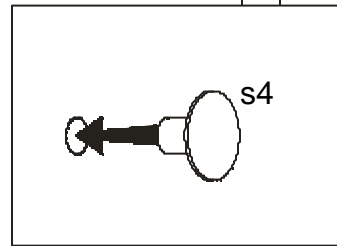
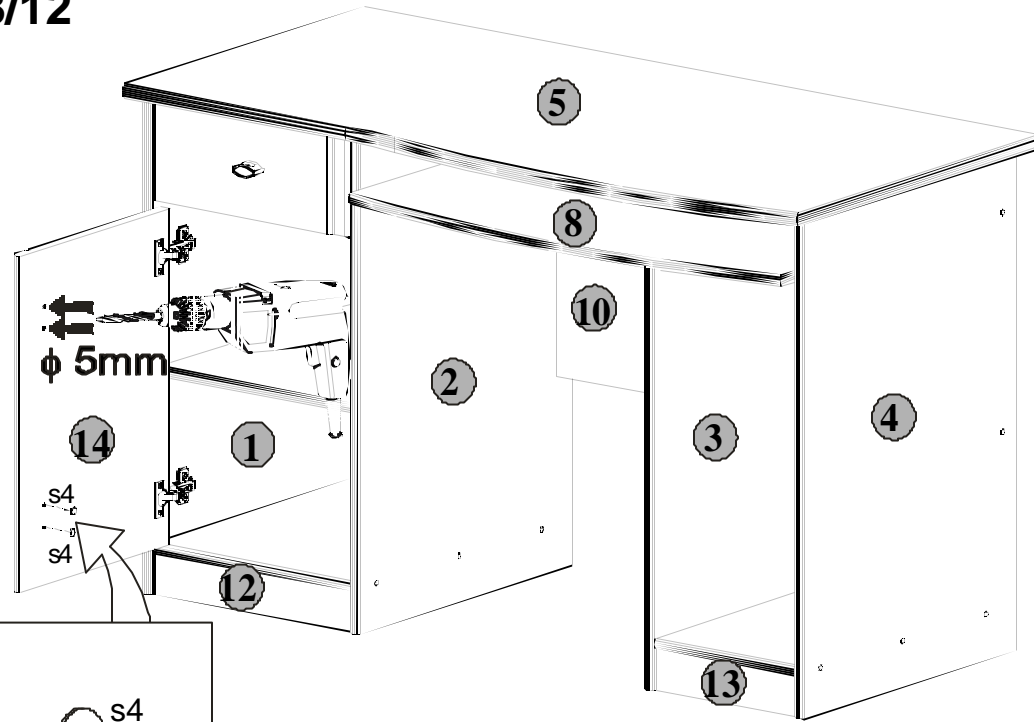

Uwaga! Podczas wykonywania tej czynności należy zwrócić szczególną uwagę, ponieważ zachodzi niebezpieczeństwo skażenia i uszkodzenia frontu!

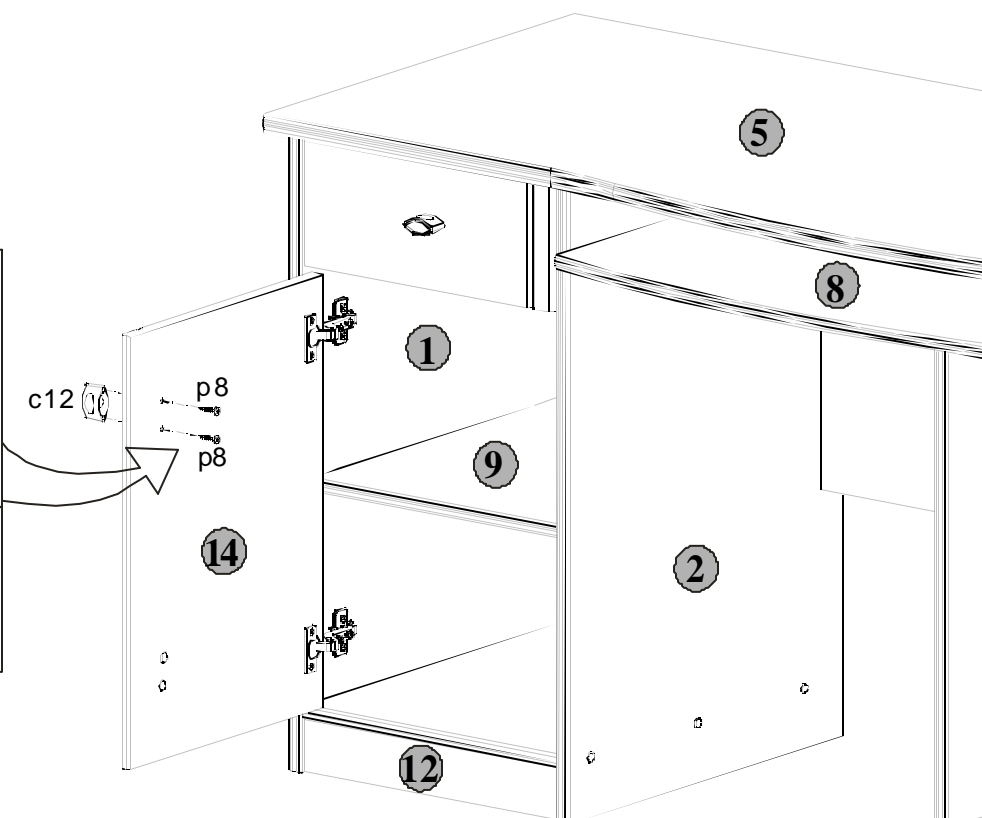
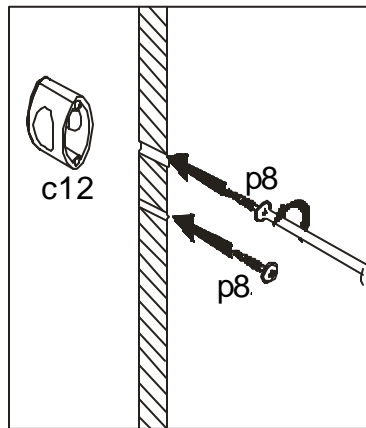

2x  s4

13 kbiu/8/12



2x  p8
1x  c12

INSTRUKCJA MONTAŻU FITTING-UP INSTRUCTION AUFBAUANLEITUNG



POP System kbiu/8/12

Producent:
BLACKREDWHITES.A.
UL. KRZESZOWSKA 63
23-400 BILGORAJ

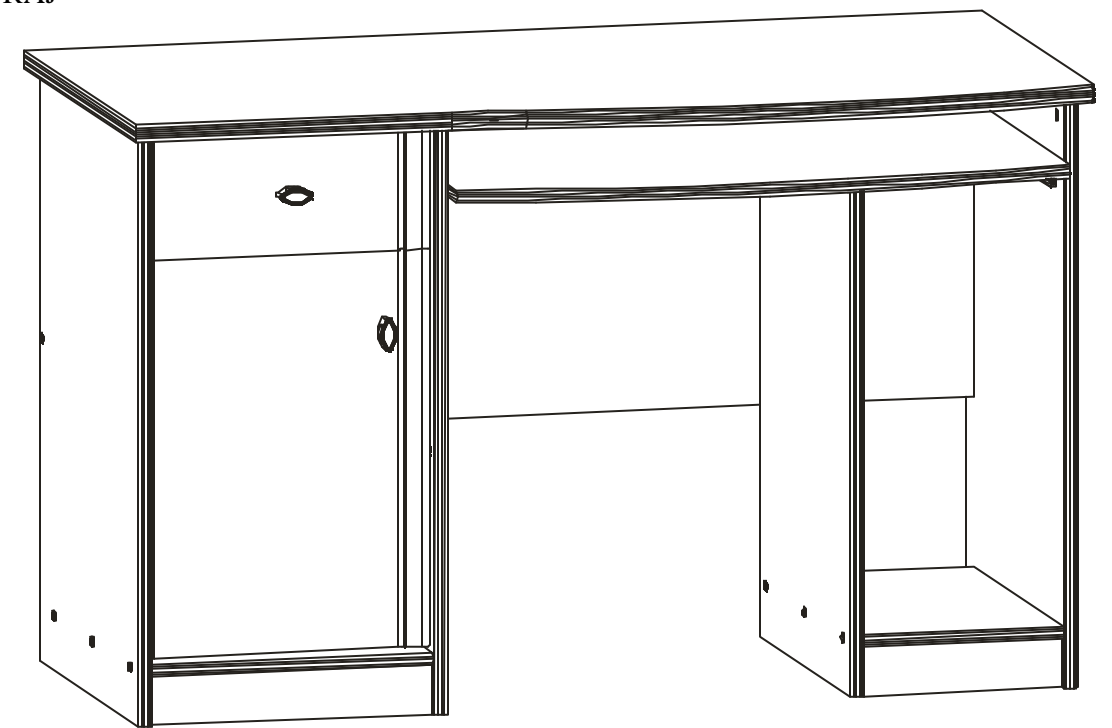

75x120x60 /cm/

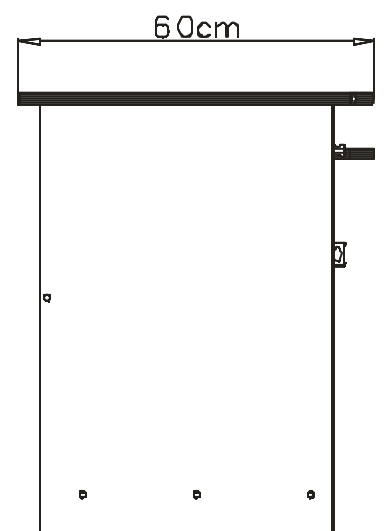
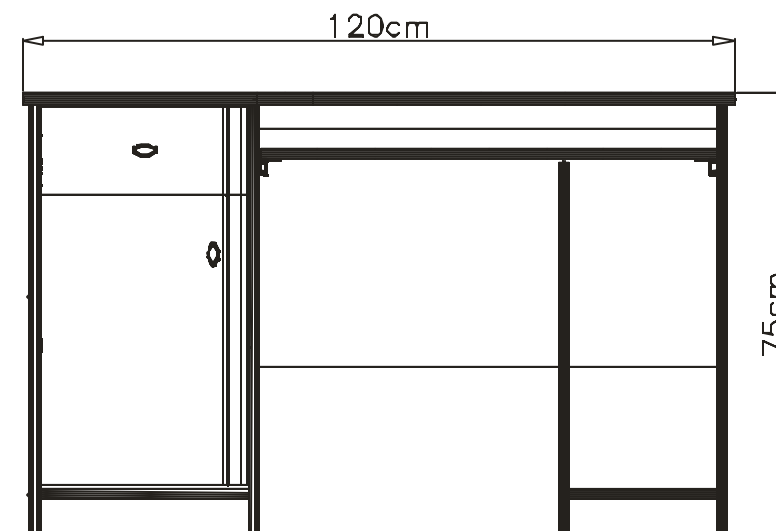

POP System

kbiu/8/12

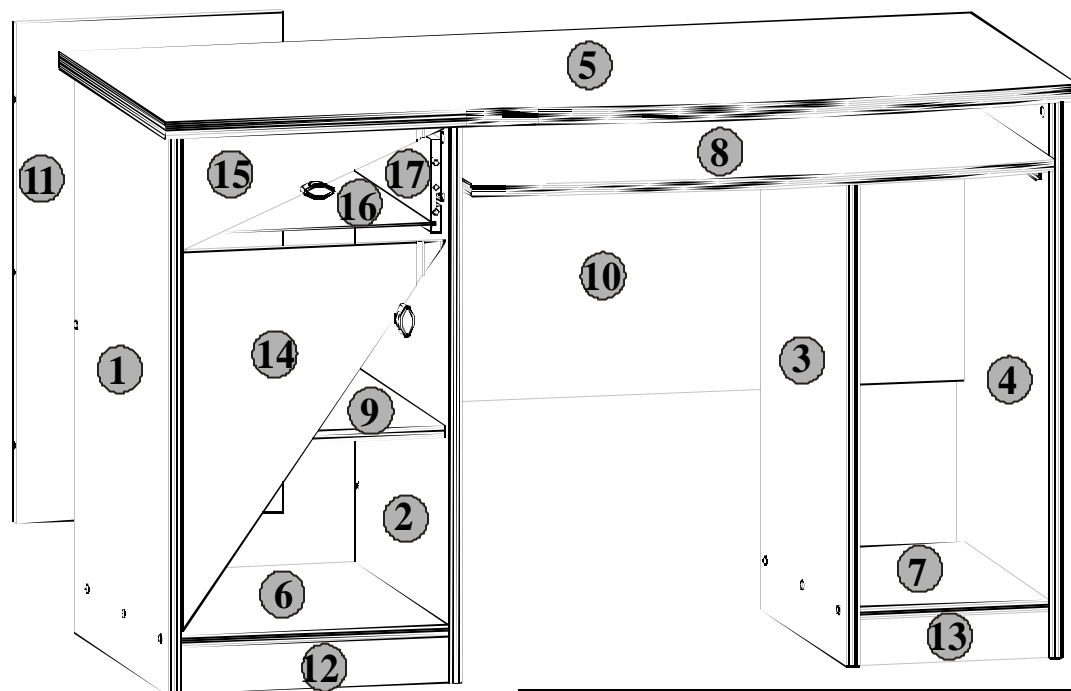

Symbolelementu Element symbol Elementeszeichen	Wymiary Measurements Ausmaß	Kod Code Kode
1	725x495	SK1-154
2	725x495	SK1-155
3	630x455	SK1-112
4	725x495	SK1-157
5	1200x600	SK1-213
6	352x490	SK1-340
7	250x450	SK1-333
8	768x461	SK1-342
9	351x450	SK1-343
10	772x400	SK1-345
11	649x352	SK1-346
12	352x60	SK1-401
13	250x60	SK1-408
14	490x348	SK1-026
15	150x348	SK1-031
16	420x331	SK1-957
17	1185x120	SK1-506

Paczki:/Packages:/Paketen:

Korpus1/Body1/Möbelkorps1
Korpus2/Body2/Möbelkorps2
Akcesoria/Accessories/Zubehör

Akcesoria/Accessories/Zubehör

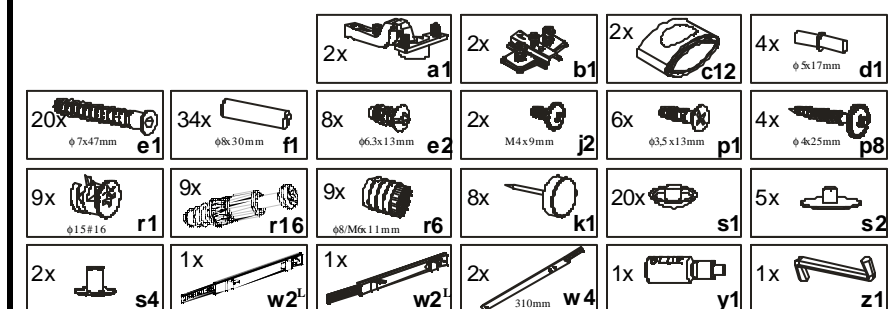

Domontazopotrzebnesa:
Youneedforfitting-up:
ZurMontagewerdenSiebrauchen:

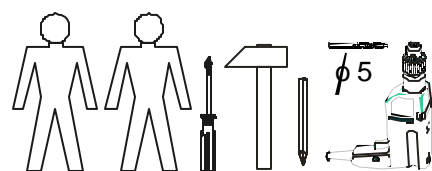

Podczasmontazu
postepowac
zgodniez instrukcja.

Whileassembling
follow
the instruction.

Montagelaut
derAufbauanleitung
durchföhren.

10 kbiu/8/12

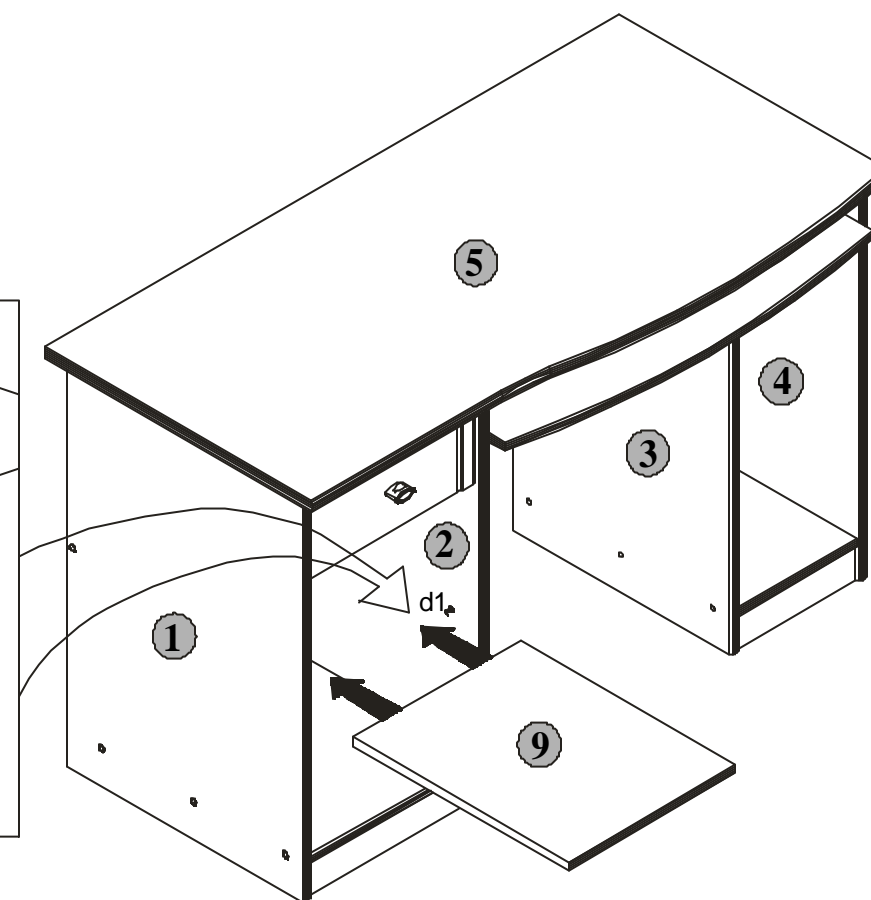
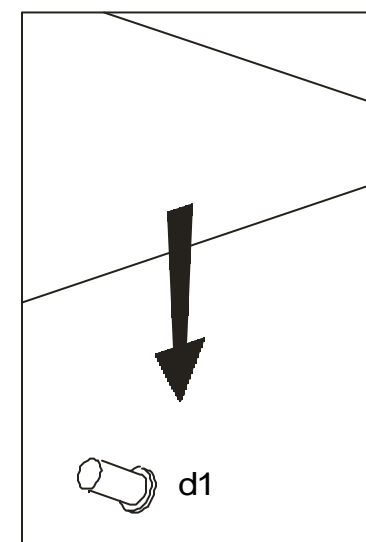

11 kbiu/8/12

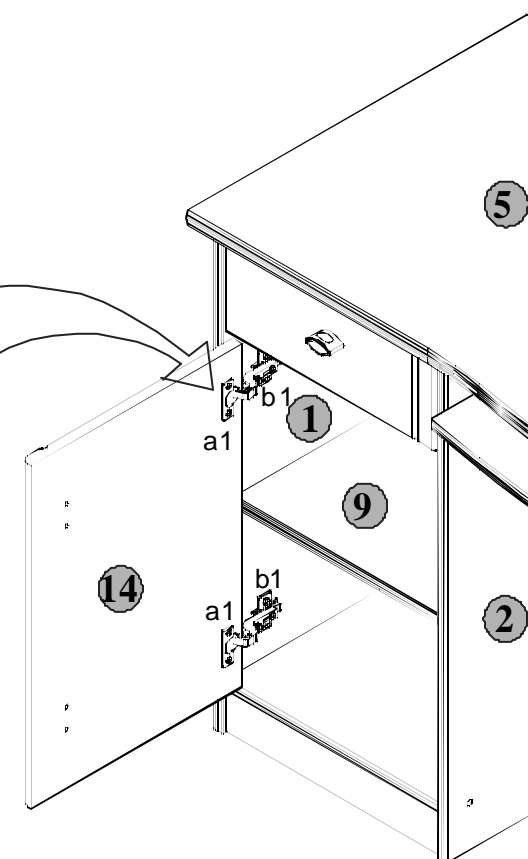
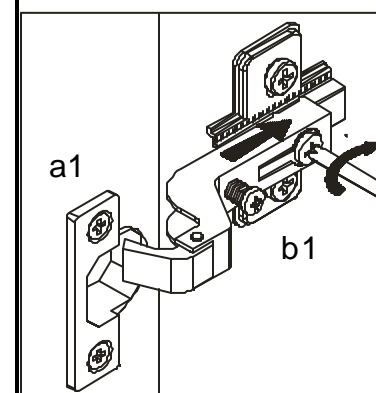
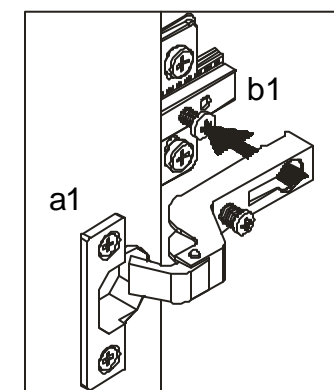

Regulacja drzwi
Adjustment of door
Türeneinstellung

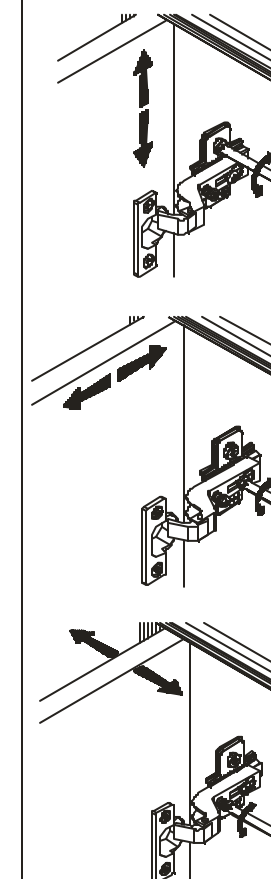

Podczas montażu
postępować
zgodnie z instrukcją.

While assembling
follow
the instruction.

Montage laut
der Aufbauanleitung
durchführen.

8 kbiu/8/12

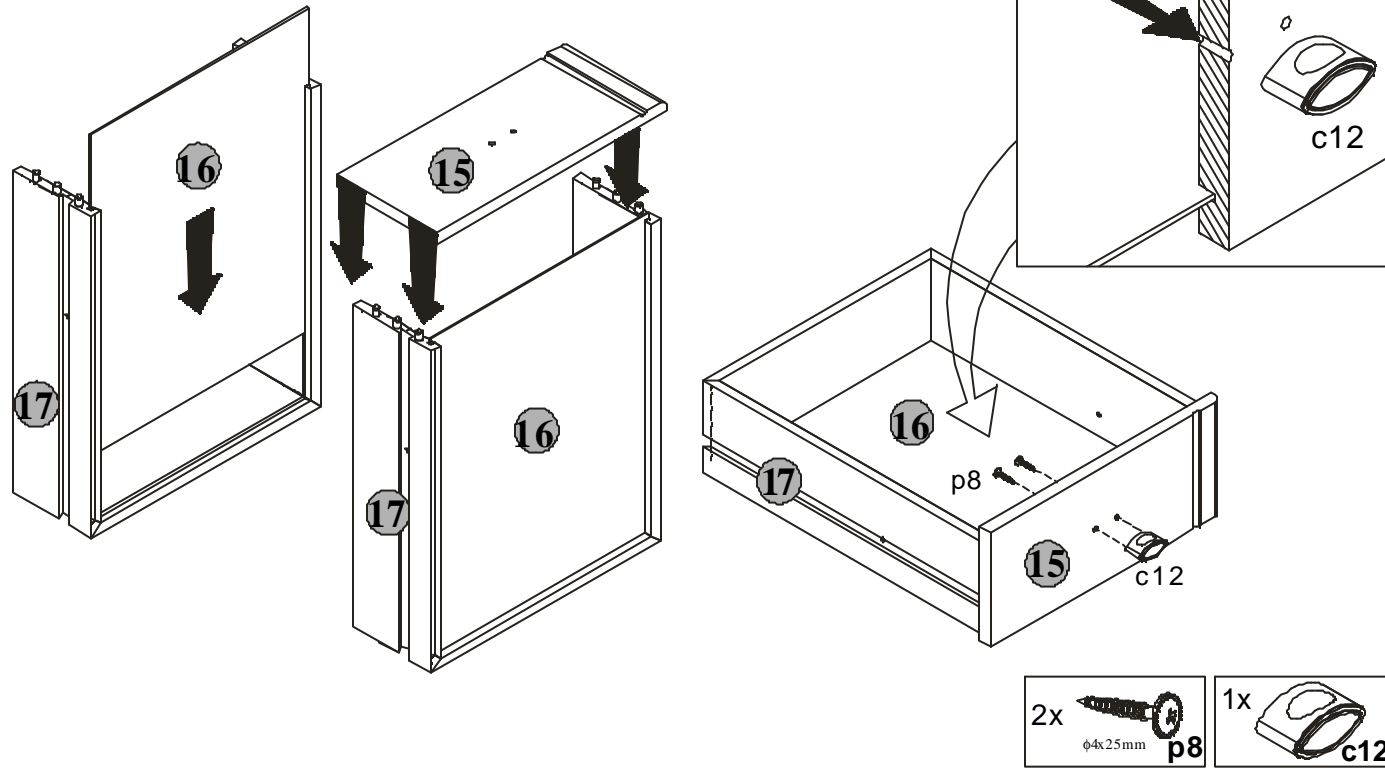

9 kbiu/8/12

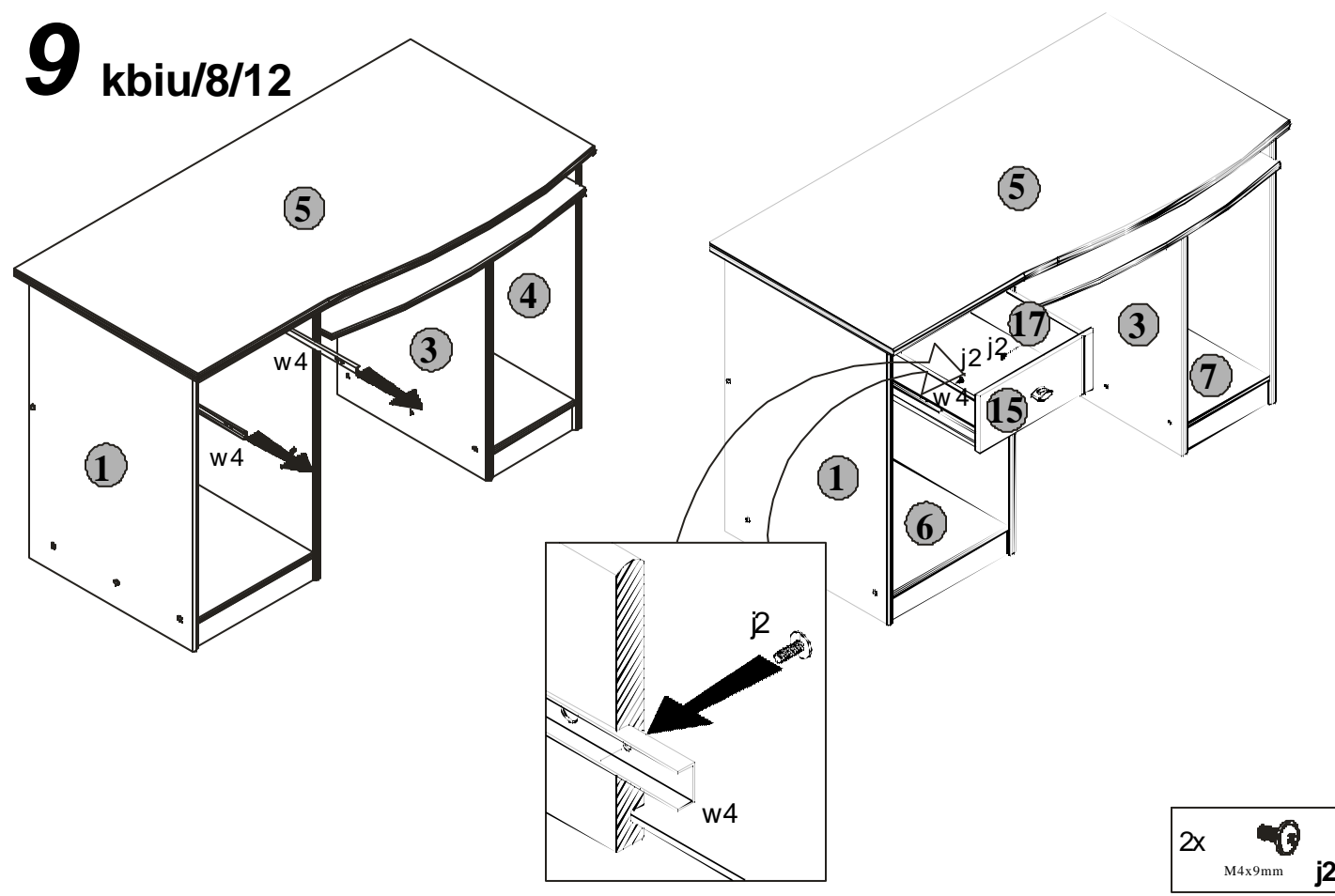

Korpus1 /Body1 /Möbelkorps1

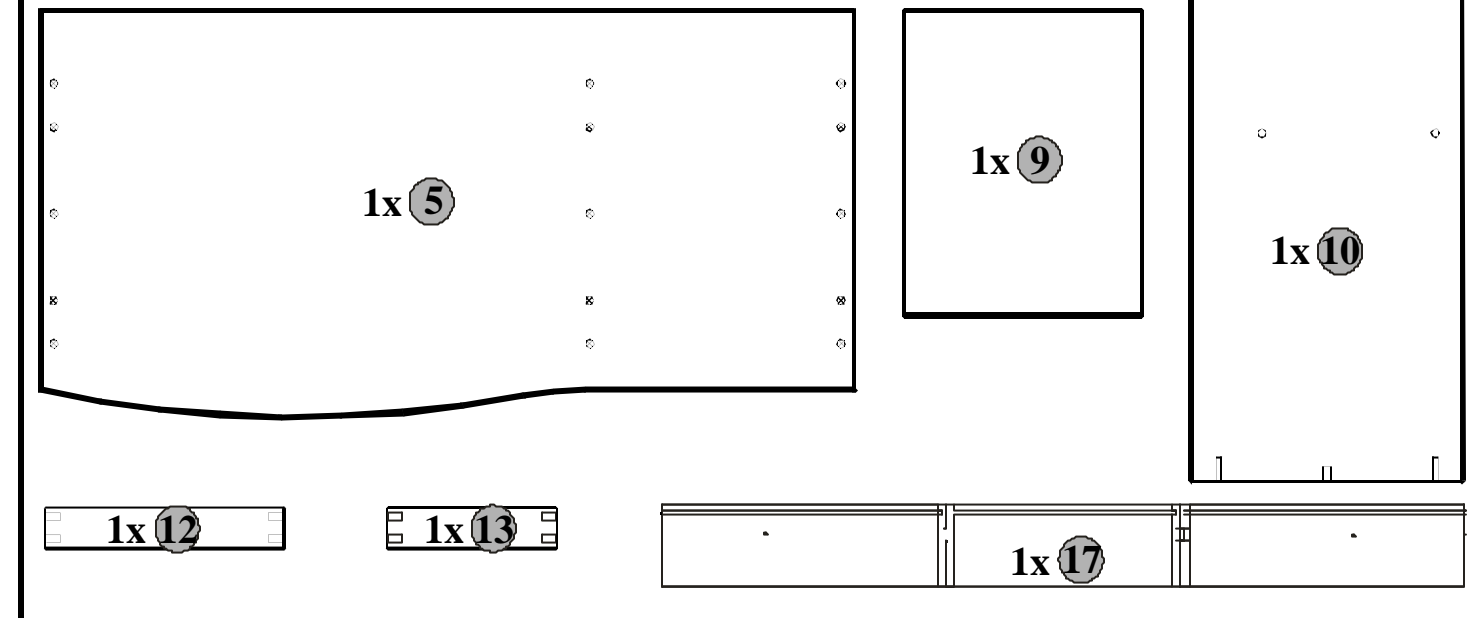

Korpus2 /Body2 /Möbelkorps2

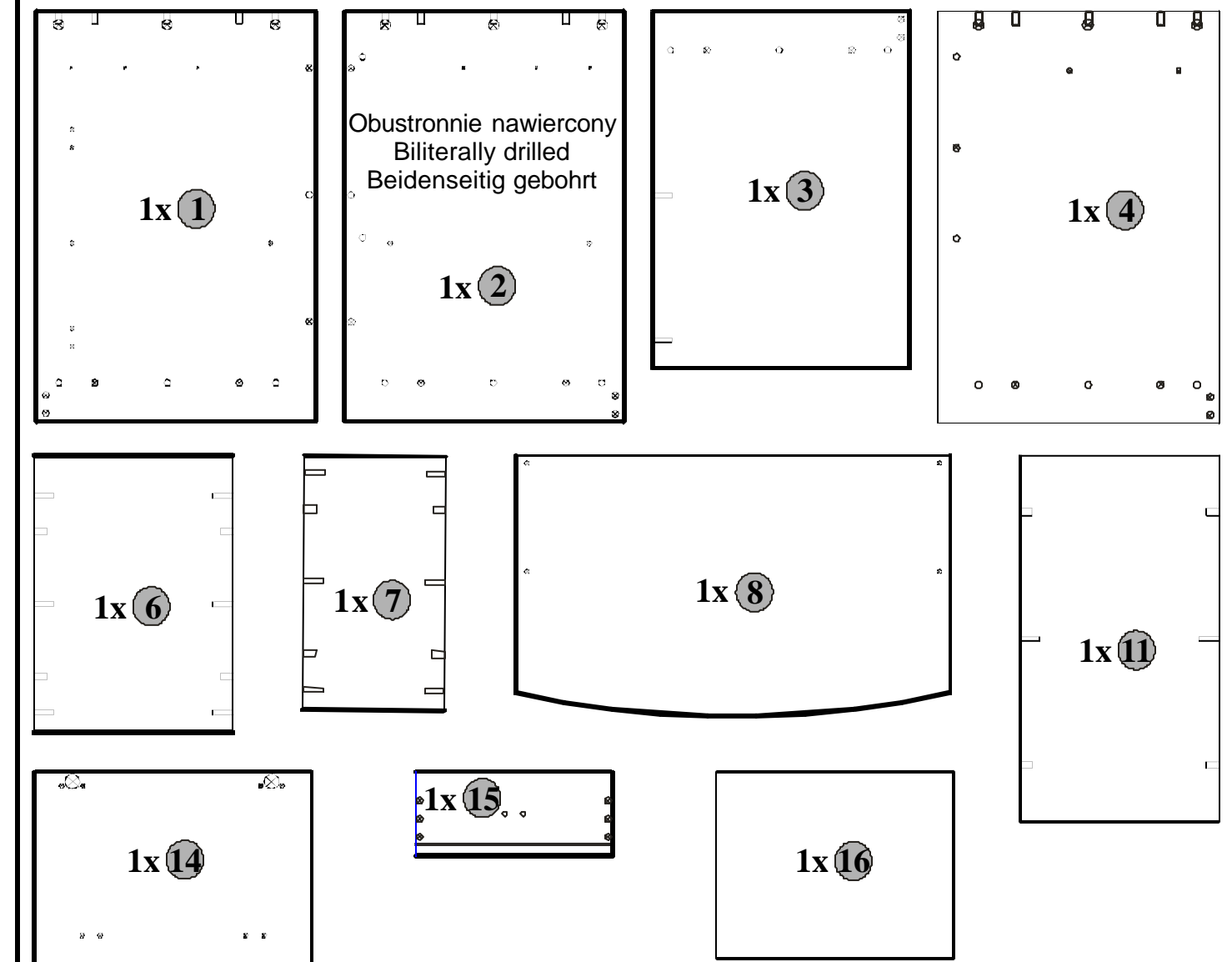

Podczas montażu
postępowac
zgodnie z instrukcją.

While assembling
follow
the instruction.

Montage laut
der Aufbauanleitung
durchführen.

1 kbiu/8/12

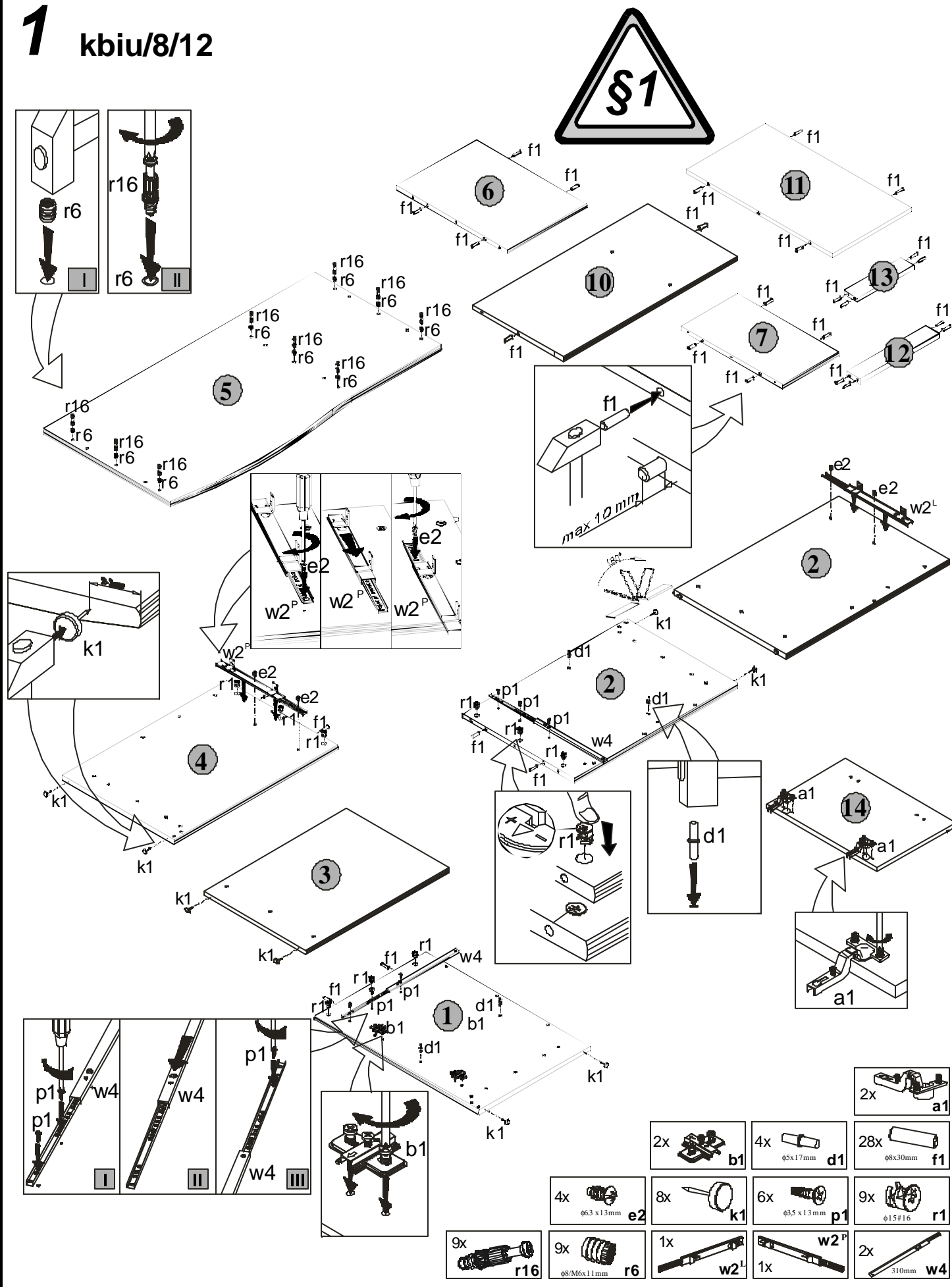

2x		4x		28x	
4x		8x		6x	
9x		1x		9x	
9x		1x		2x	

Podczas montażu
postępowac
zgodnie z instrukcją.

While assembling
follow
the instruction.

Montage laut
der Aufbauanleitung
durchführen.

6 kbiu/8/12

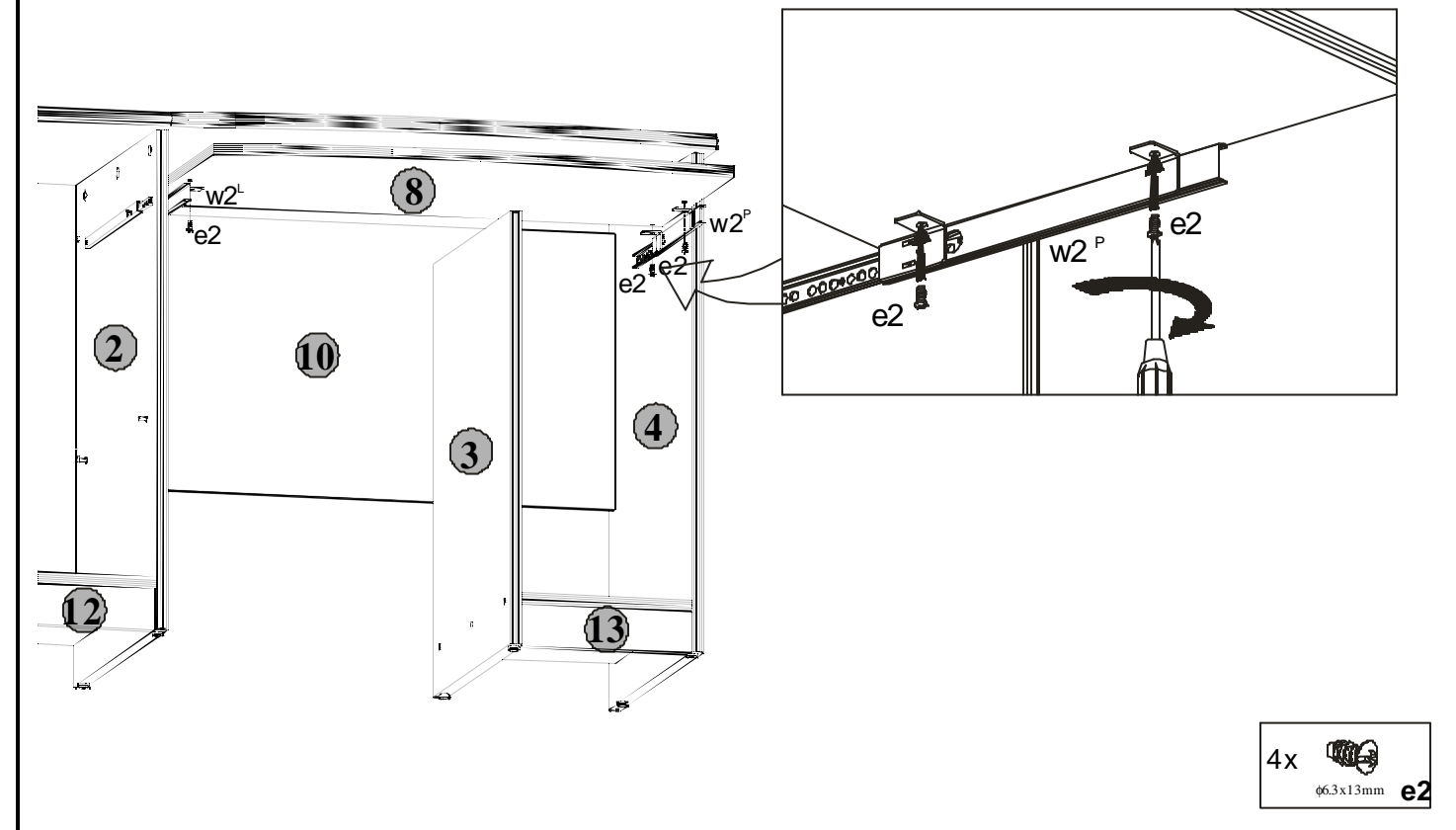

4x	
----	--

7 kbiu/8/12

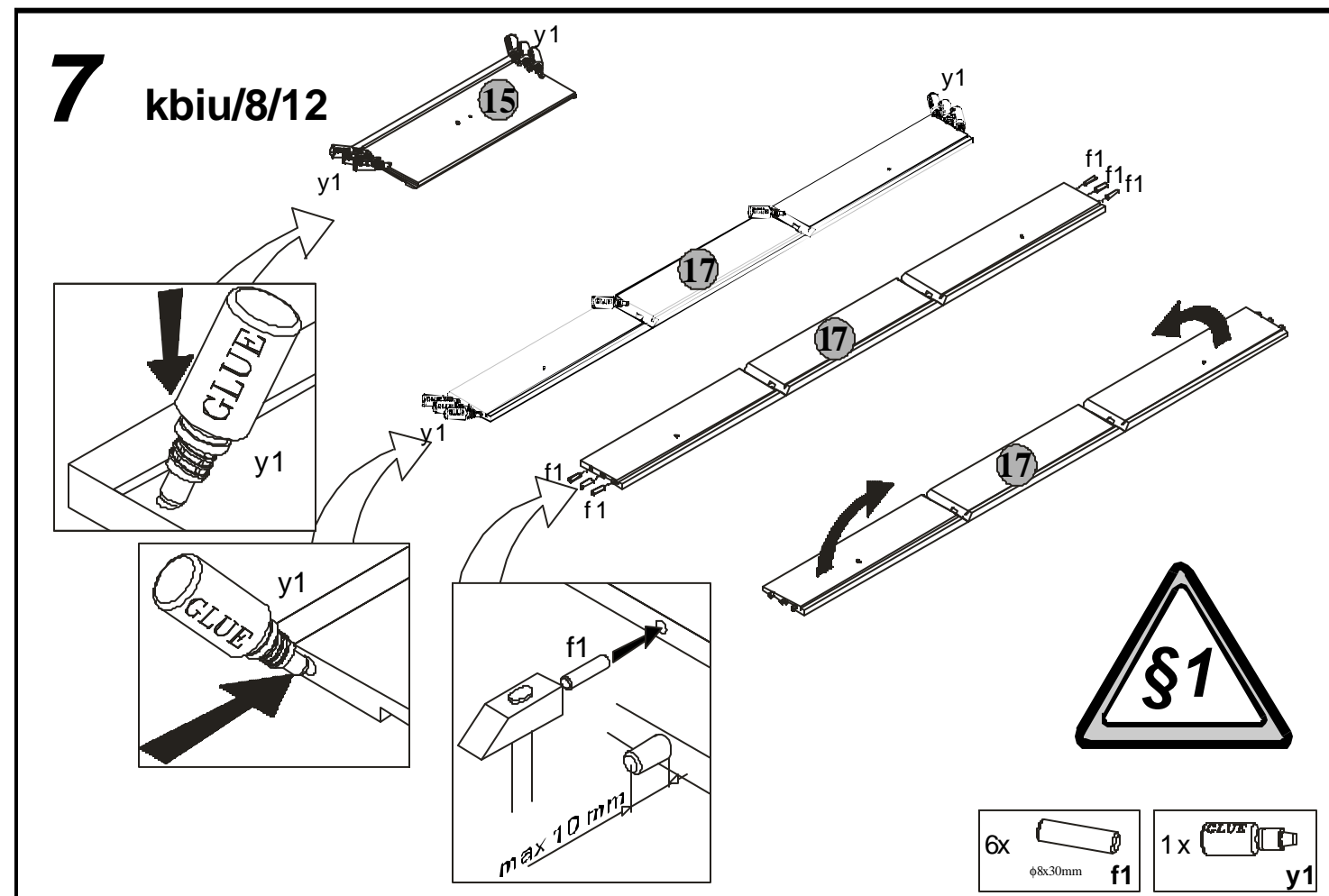

6x		1x	
----	--	----	--

Podczas montażu
postępować
zgodnie z instrukcją.

While assembling
follow
the instruction.

Montageanleitung
der Aufbauanleitung
durchführen.

4 kbiu/8/12

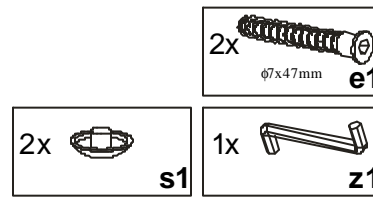
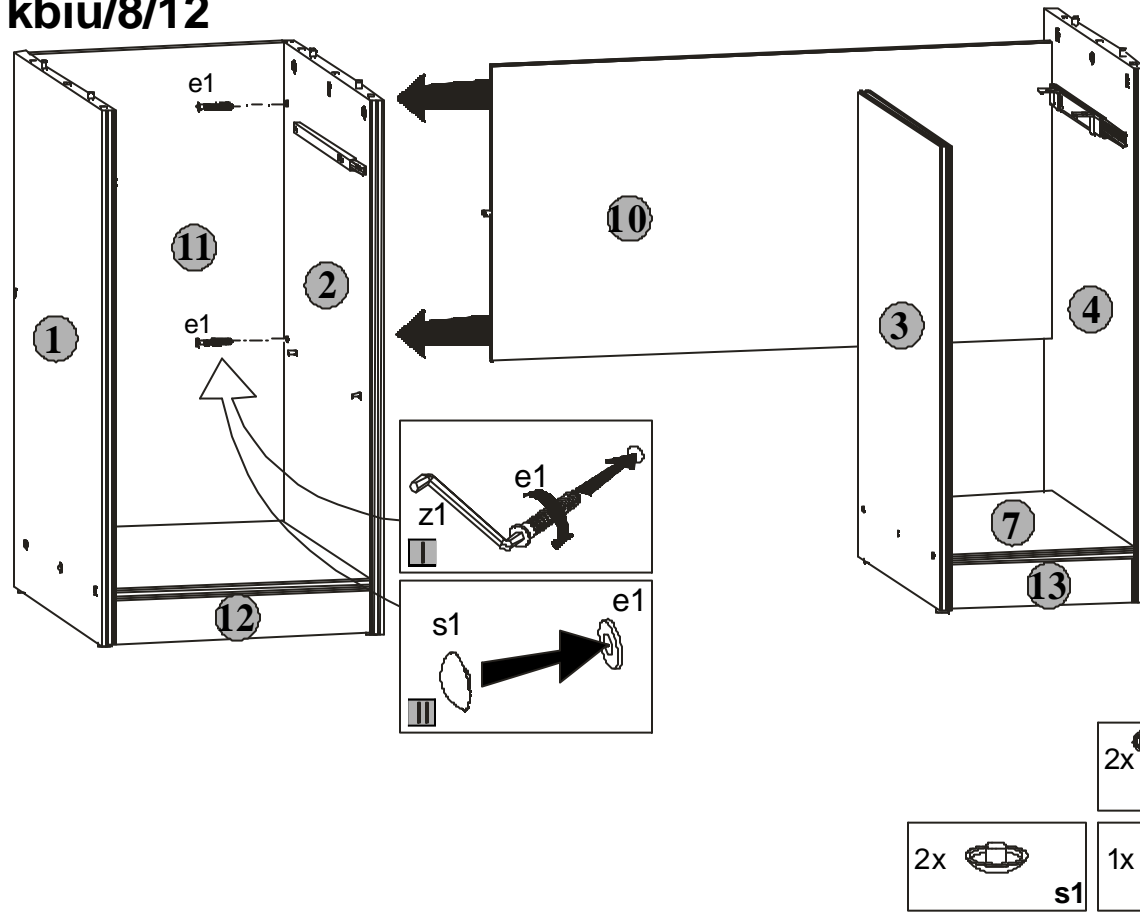

Podczas montażu
postępować
zgodnie z instrukcją.

While assembling
follow
the instruction.

Montageanleitung
der Aufbauanleitung
durchführen.

2 kbiu/8/12

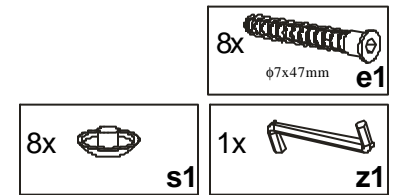
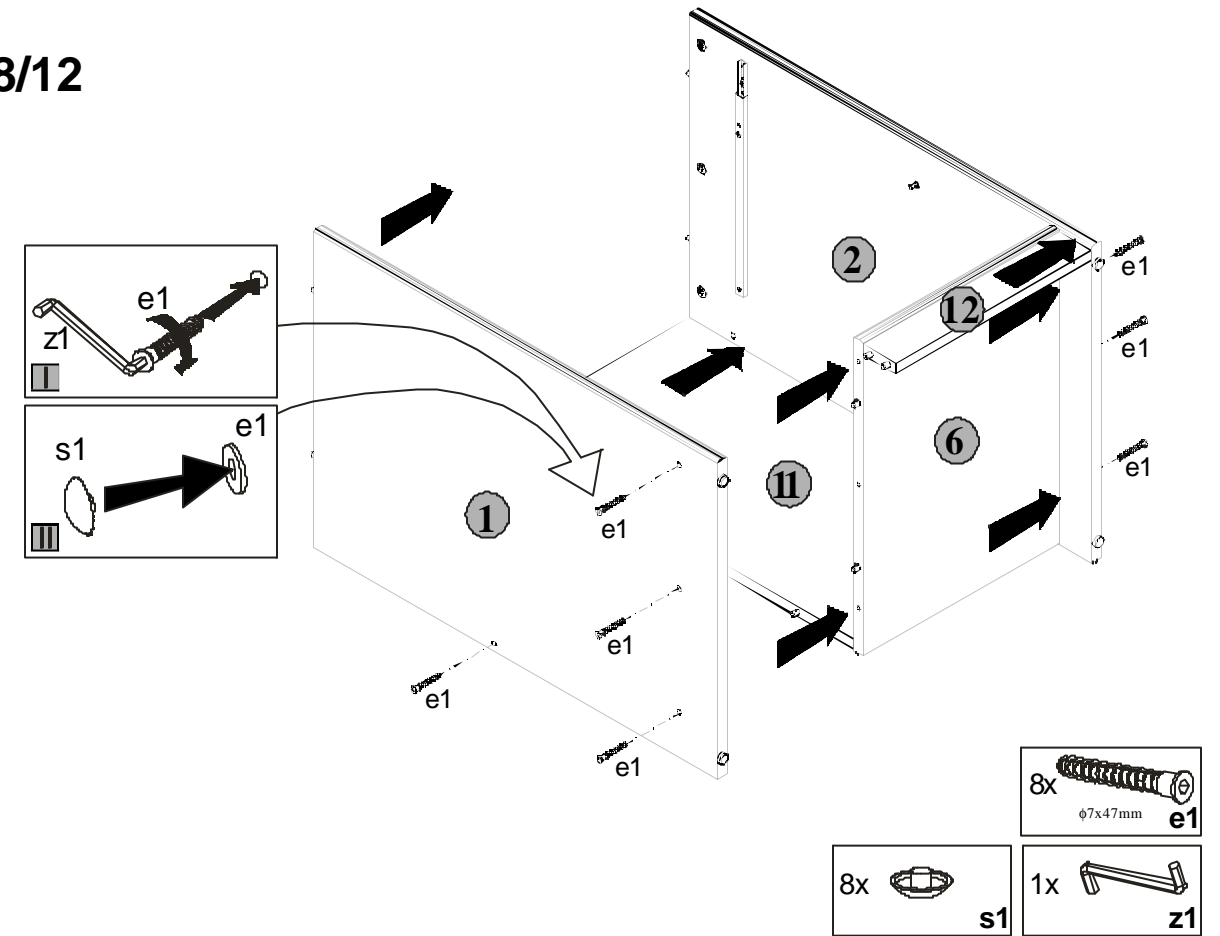

5 kbiu/8/12

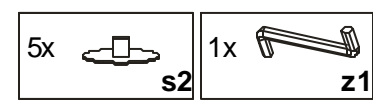
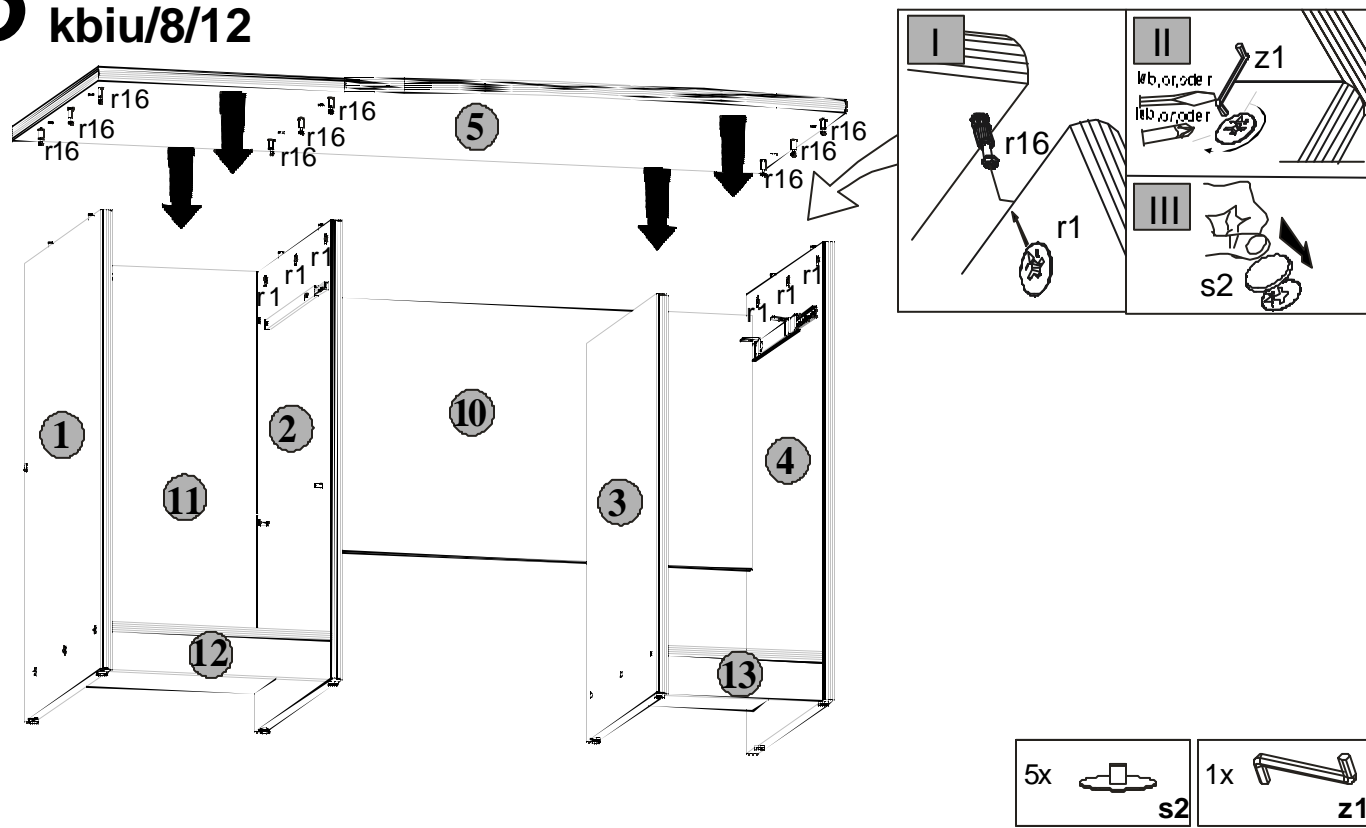

3 kbiu/8/12

