

Podczas montażu  
postępować  
zgodnie z instrukcją.

While assembling  
follow  
the instruction.

Montage laut  
der Aufbauanleitung  
durchführen.

# 16 kł/20/10

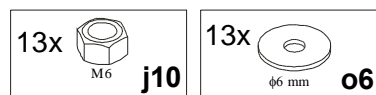
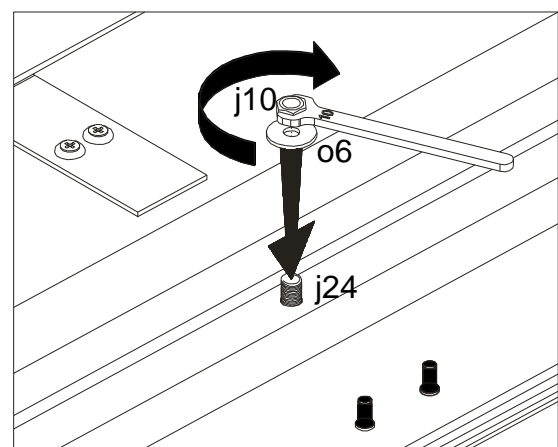
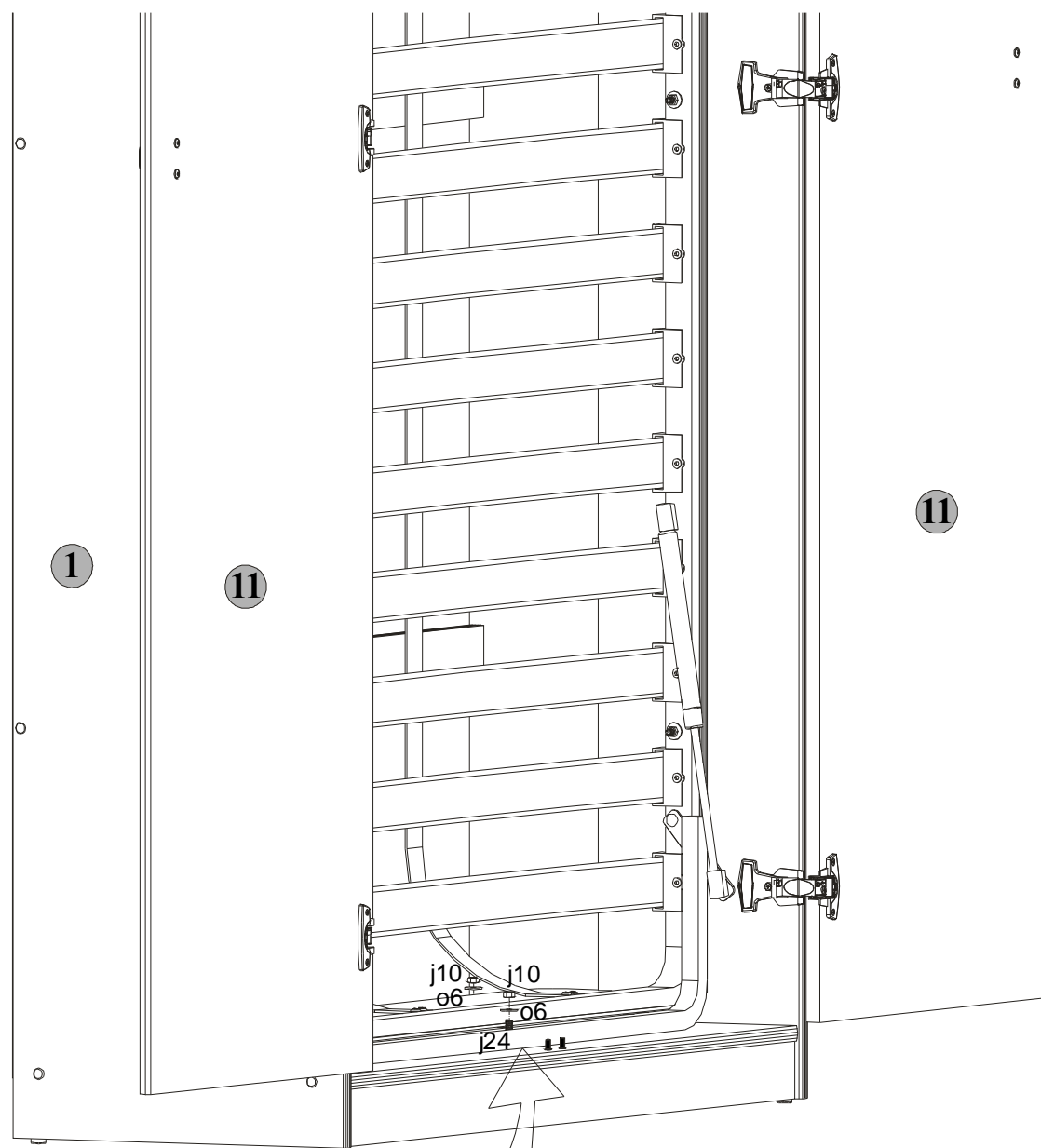

## INSTRUKCJA MONTAŻU FITTING-UP INSTRUCTION AUFBAUANLEITUNG

# POP SYSTEM

kł/20/10



BLACK RED WHITE®

BLACK RED WHITE S.A.  
UL. KRZESZOWSKA 63  
23-400 BIŁGORAJ  
e-mail: brw@brw.com.pl, <http://www.brw.com.pl>

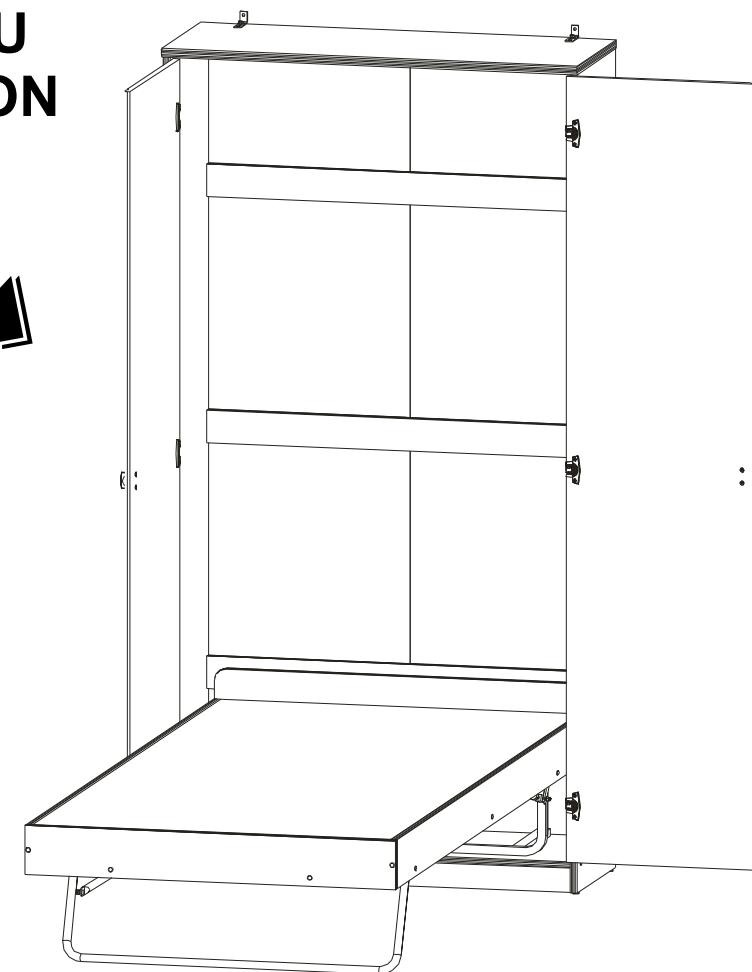

205x104,5x40/201,5 /cm/

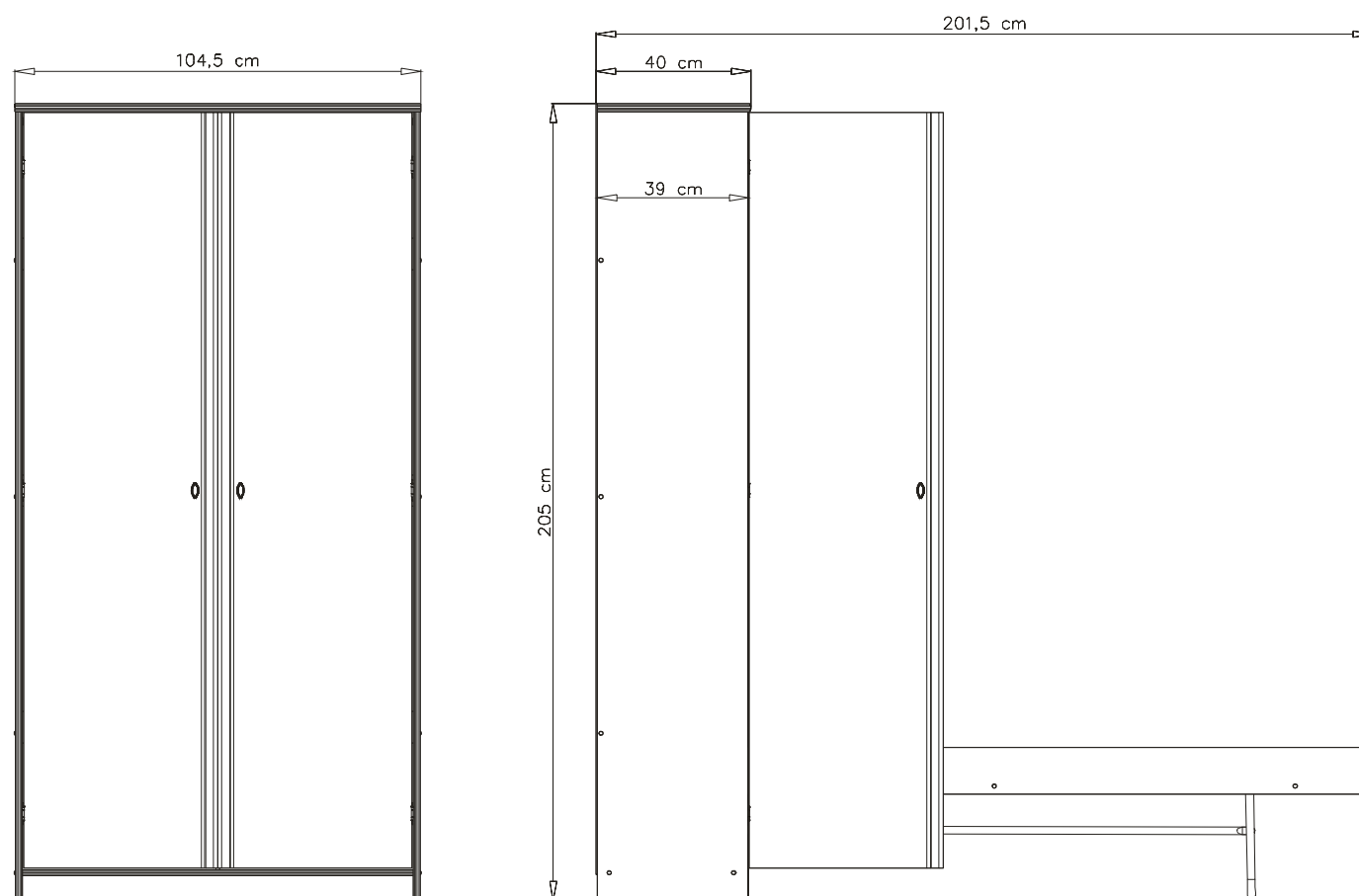



# POP SYSTEM

kł/20/10

Symbol elementu Element symbol Elementeszeichen	Wymiary Measurements Ausmaß	Kod Code Kode
1	2024x389	SK1-1107
2	2024x389	SK1-1108
3	1042x394	SK1-233
4	1004x385	SK1-391
5	1004x60	SK1-450
6	1004x80	SK1-492
7	1886x120	SK1-1109
8	1886x120	SK1-1135
9	931x120	SK1-1110
10	931x165	SK1-1111
11	1942x497	SK1-038
12	1981x516	SK1-928
14		OM-188
15		MT-189

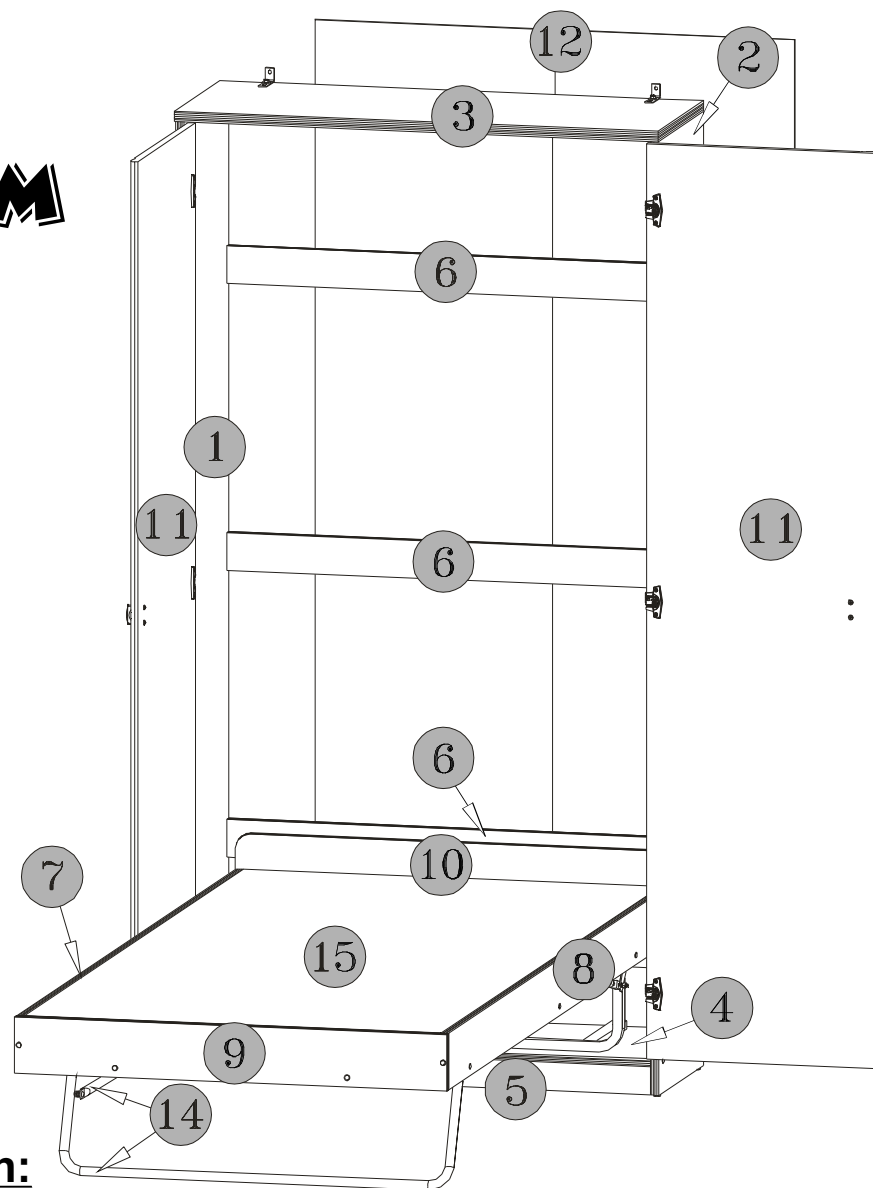

## Paczki:/Packages:/Paketen:

- Korpus1 /Body1 /Möbelkorps1
- Korpus2 /Body2 /Möbelkorps2
- Korpus4 /Body4 /Möbelkorps4
- Fronty /Fronts /Möbelfronten
- Akcesoria /Accessories /Zubehör

Akcesoria /Accessories /Zubehör					
6x a15 <sup>1</sup>	6x a15 <sup>2</sup>	6x a15 <sup>3</sup>	2x c12	2x d1 φ5x17 mm	16x e1 φ7x50 mm
12x e3 φ6x13 mm	29x f1 φ8x30 mm	2x f3 φ10 mm	13x j10 M6	2x j22 M6x30 mm	8x j23 M6x45 mm
3x j24 M6x105 mm	4x k1	70x l1	3x i6	2x n28 65x25x18	13x o6 φ6 mm
12x o10	3x o11	12x p1 φ3,5x13 mm	4x p8 φ4x25 mm	2x p17 φ5x60 mm	18x p25 φ3,5x16 mm
4x r1	4x r16	4x r6	27x s1	4x s2	1x z1

Do montażu potrzebne są:  
You need for fitting-up:  
Zur Montage werden Sie brauchen:

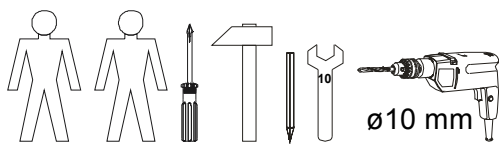

Podczas montażu  
postępować  
zgodnie z instrukcją.

While assembling  
follow  
the instruction.

Montage laut  
der Aufbauanleitung  
durchführen.

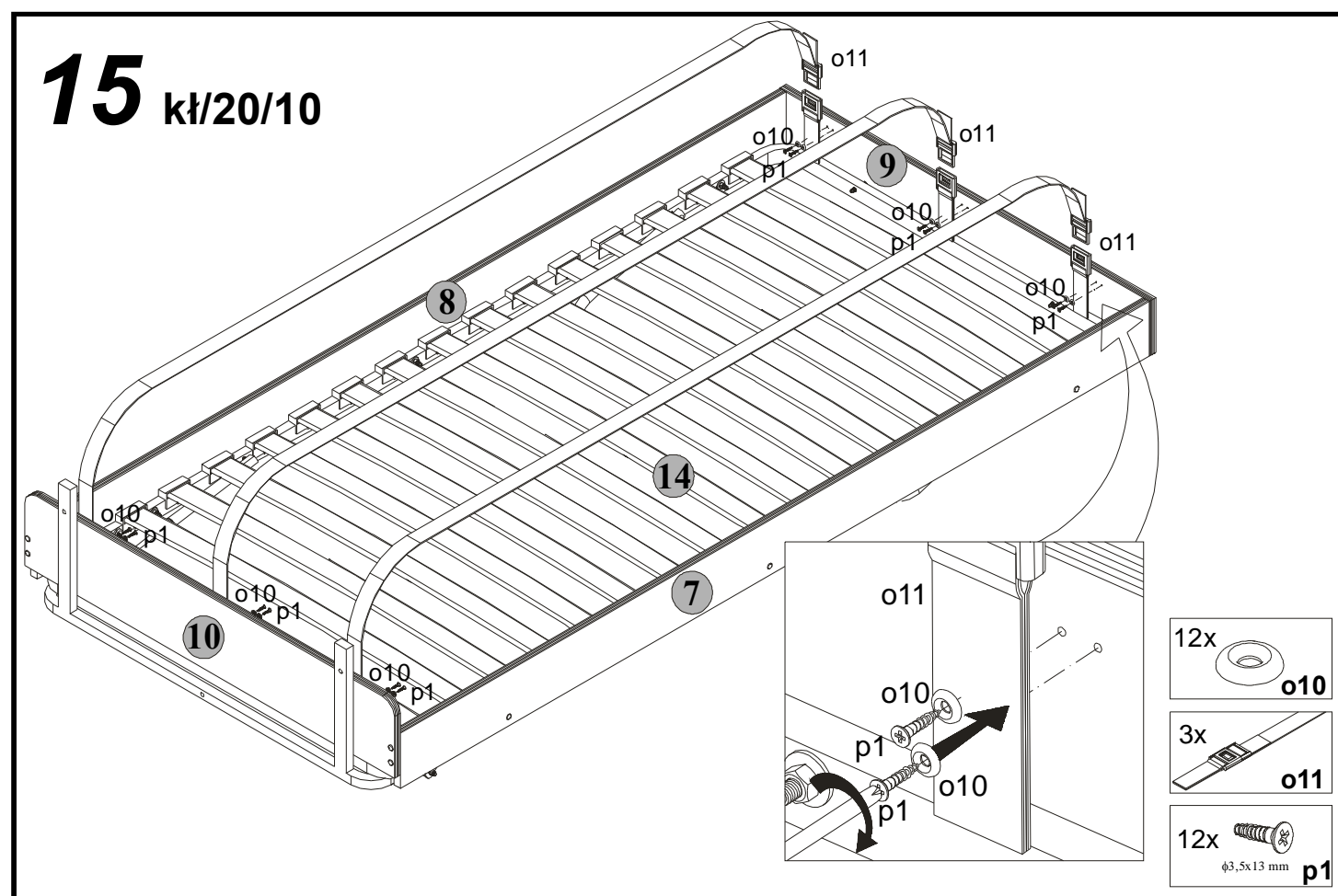
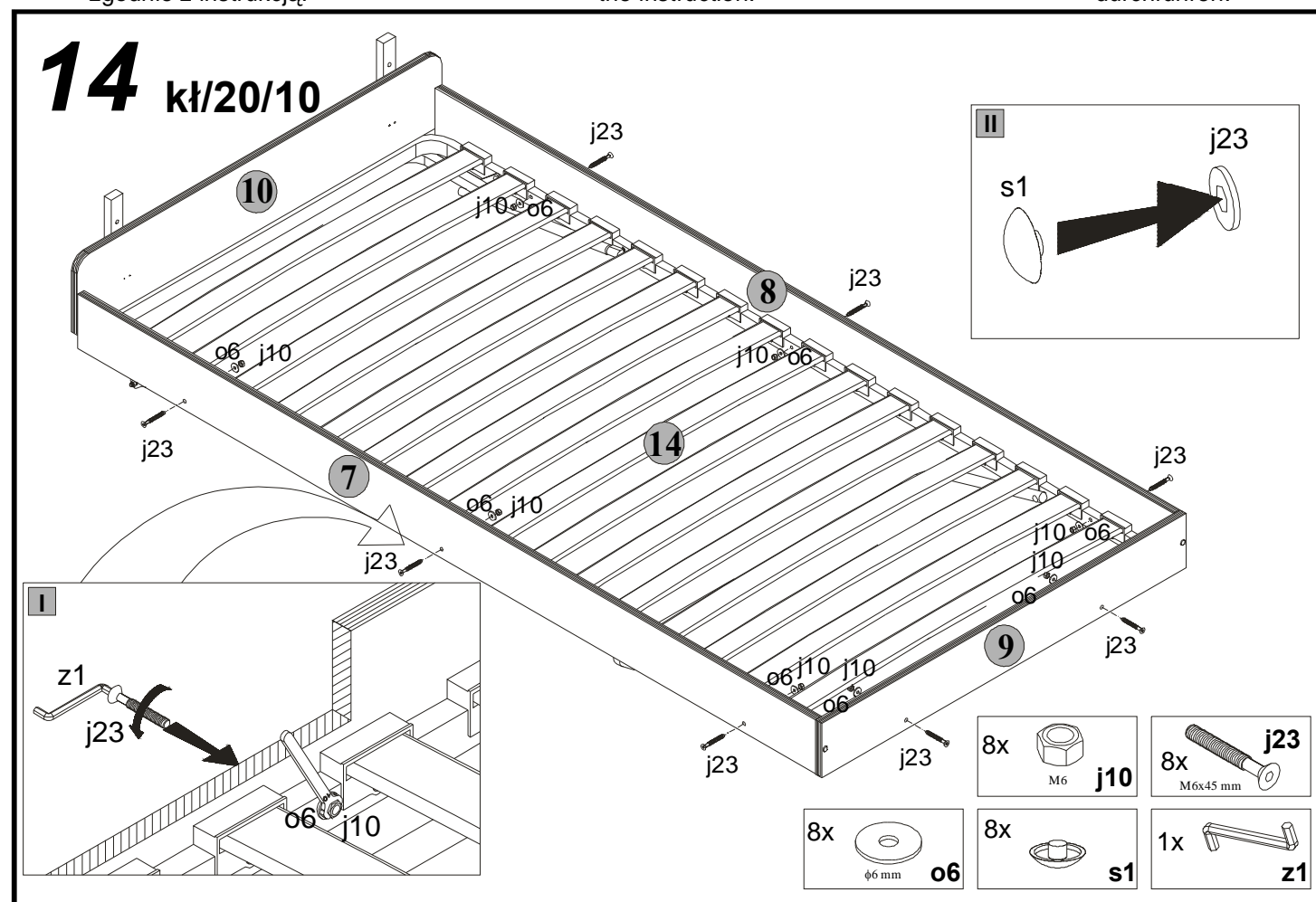

Podczas montażu  
postępować  
zgodnie z instrukcją.

While assembling  
follow  
the instruction.

Montage laut  
der Aufbauanleitung  
durchführen.

**12** kł/20/10

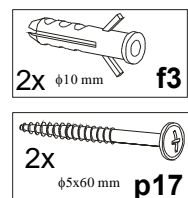
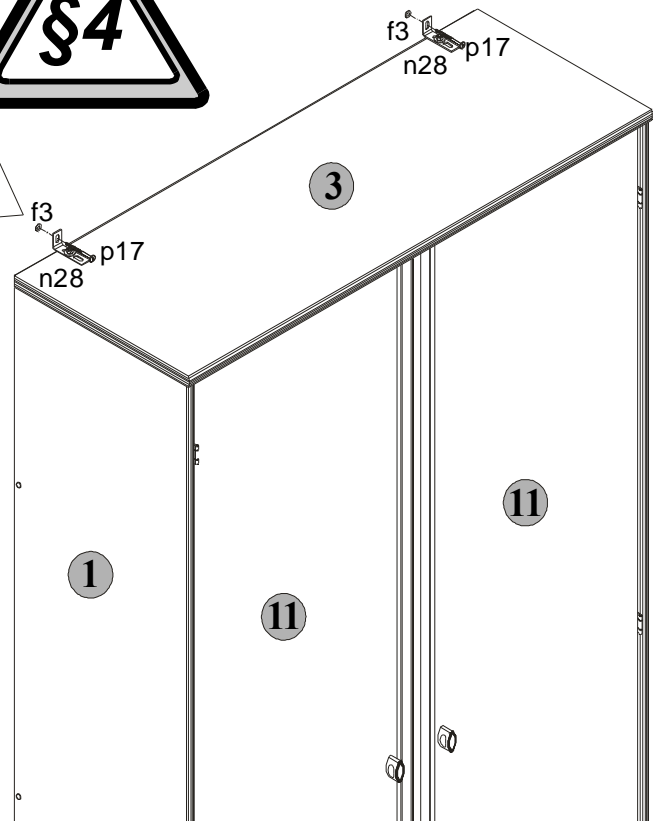
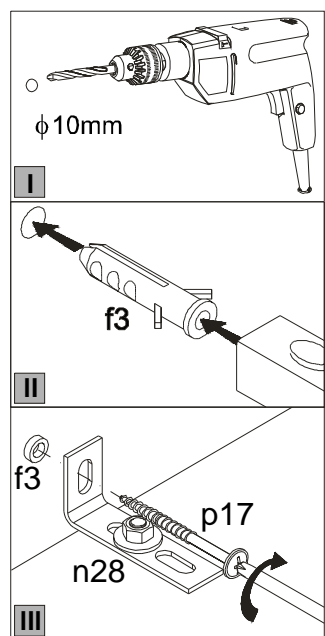

Podczas montażu  
postępować  
zgodnie z instrukcją.

While assembling  
follow  
the instruction.

Montage laut  
der Aufbauanleitung  
durchführen.

Korpus1 /Body1 /Möbelkorps1

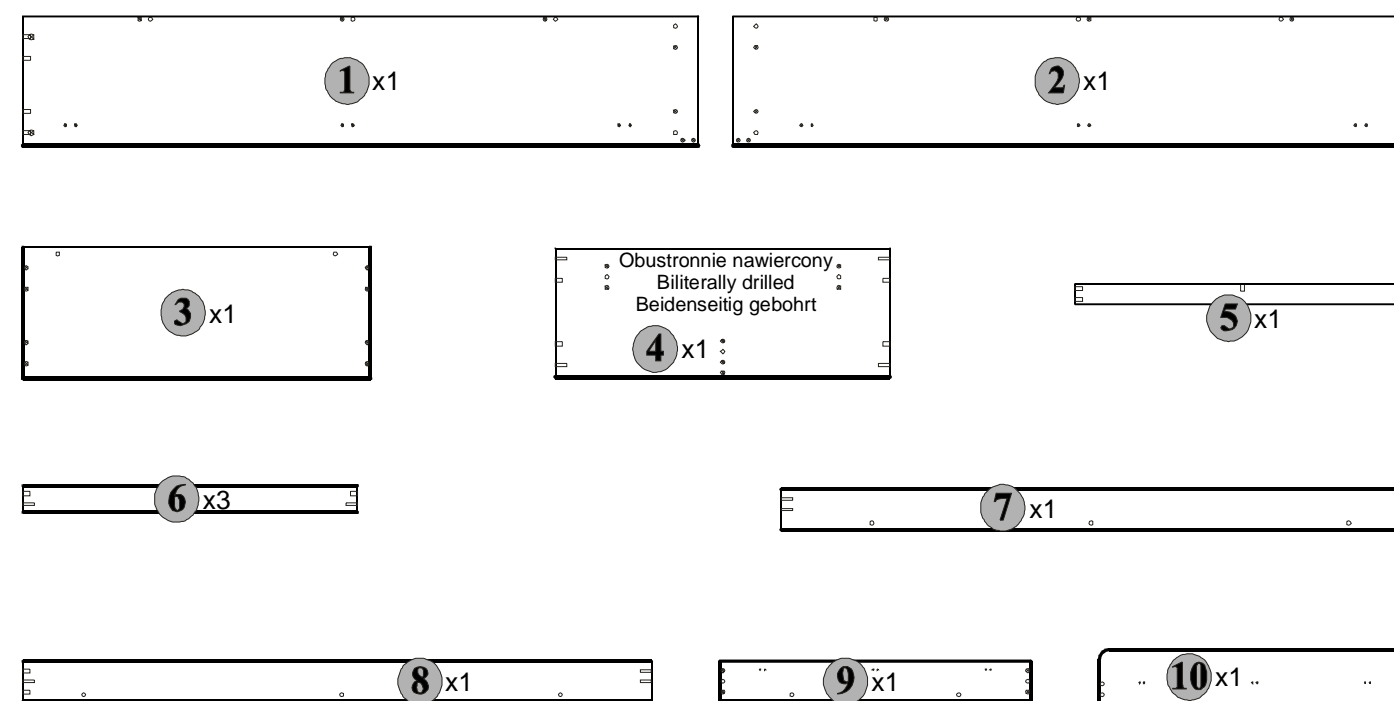

Korpus2 /Body2 /Möbelkorps2

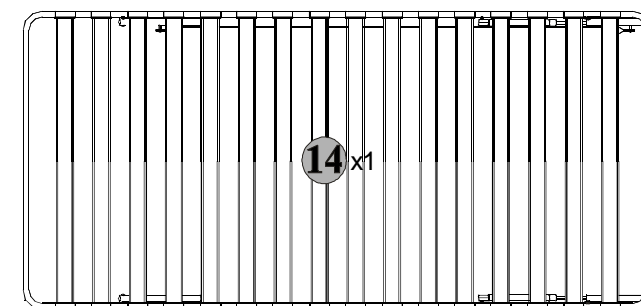

Korpus4 /Body4 /Möbelkorps4

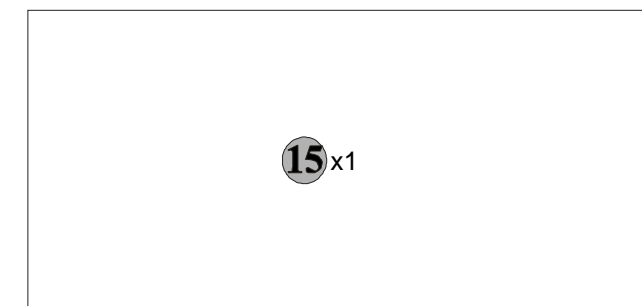

Fronty/ Fronts/ Möbelfronten

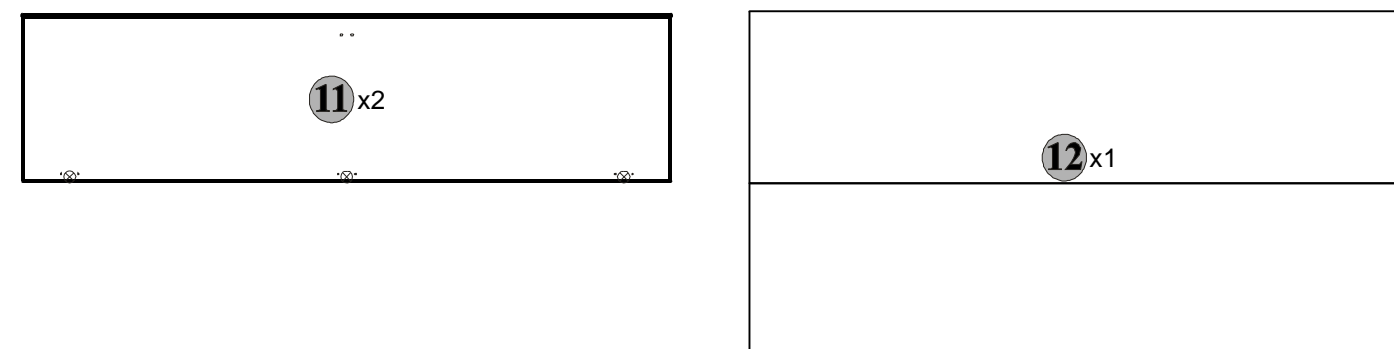

**13** kł/20/10

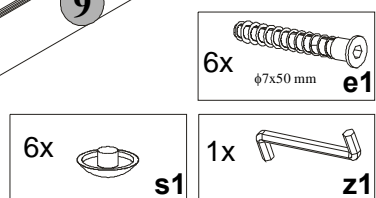
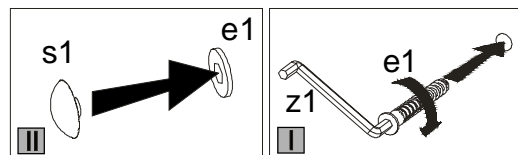
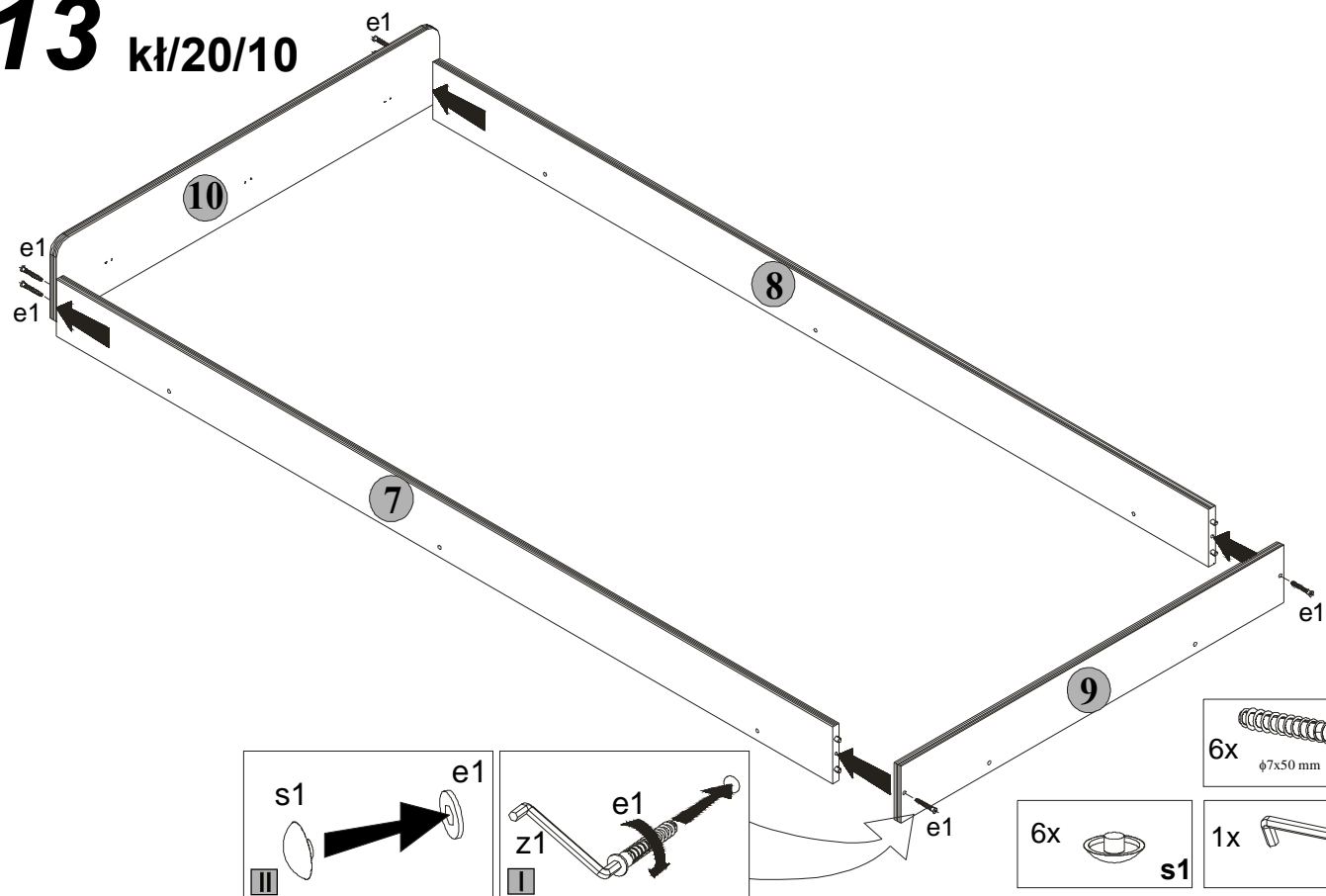

Podczas montażu  
postępować  
zgodnie z instrukcją.

While assembling  
follow  
the instruction.

Montage laut  
der Aufbauanleitung  
durchführen.

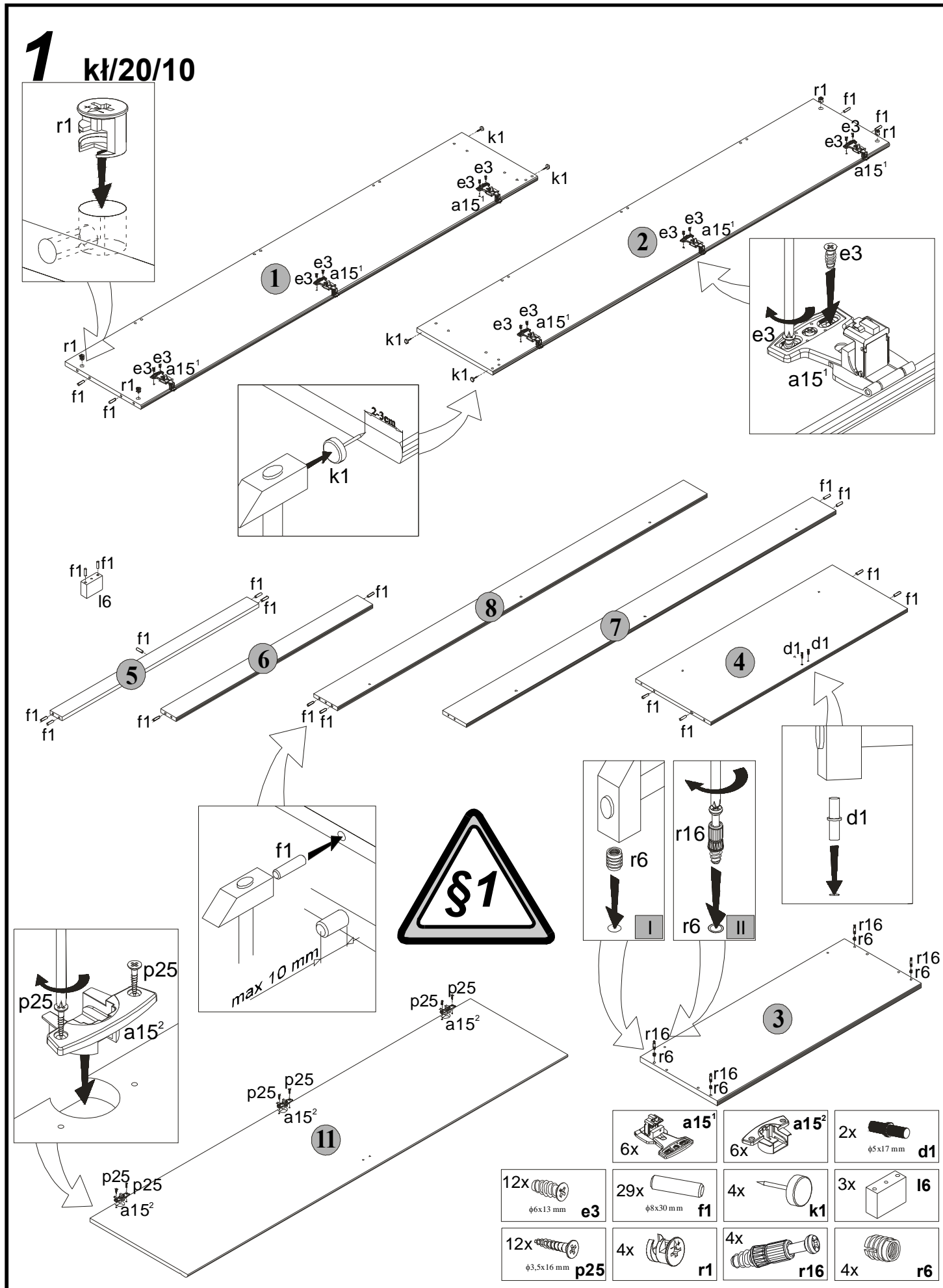

Podczas montażu  
postępować  
zgodnie z instrukcją.

While assembling  
follow  
the instruction.

Montage laut  
der Aufbauanleitung  
durchführen.

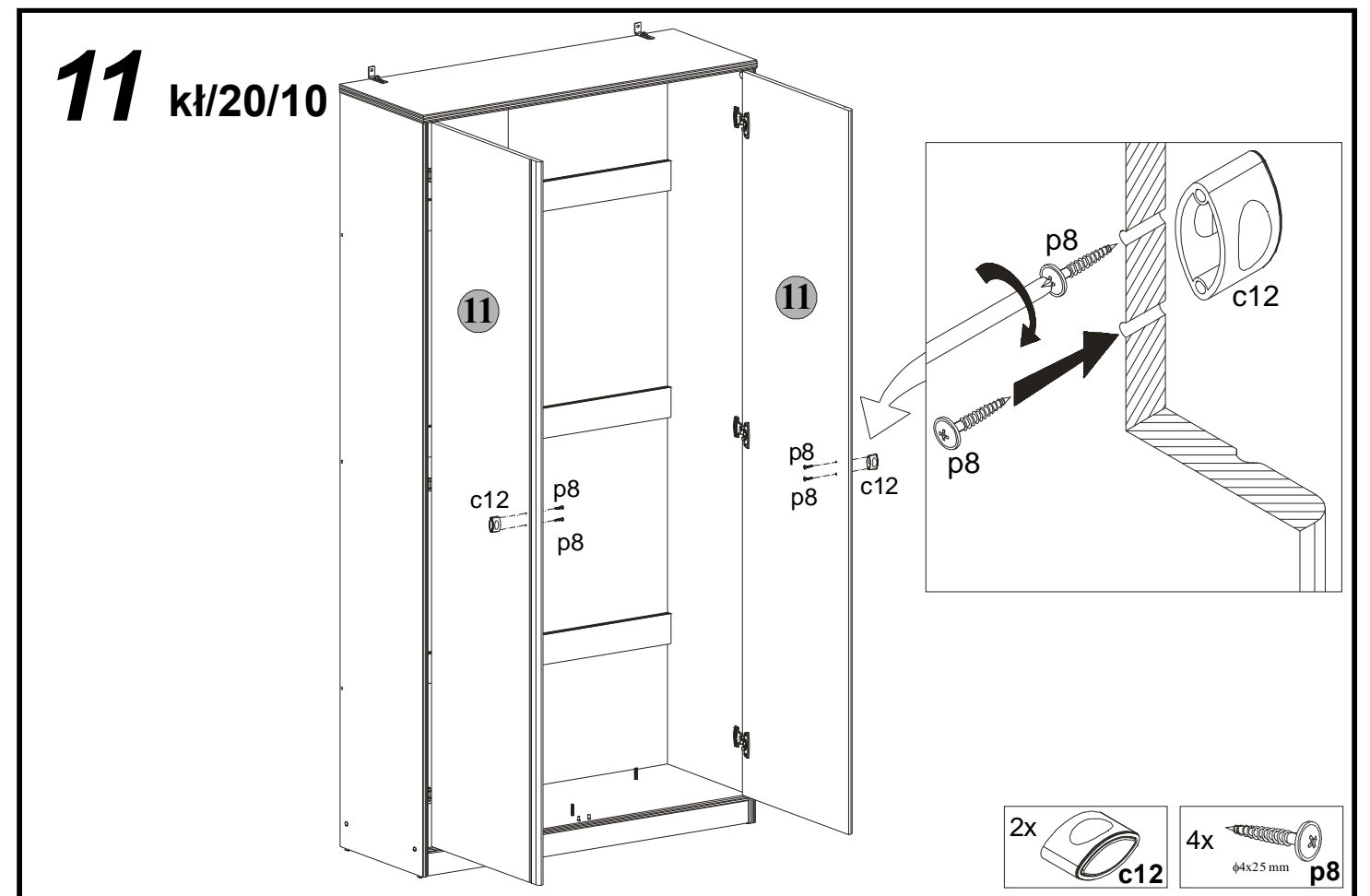
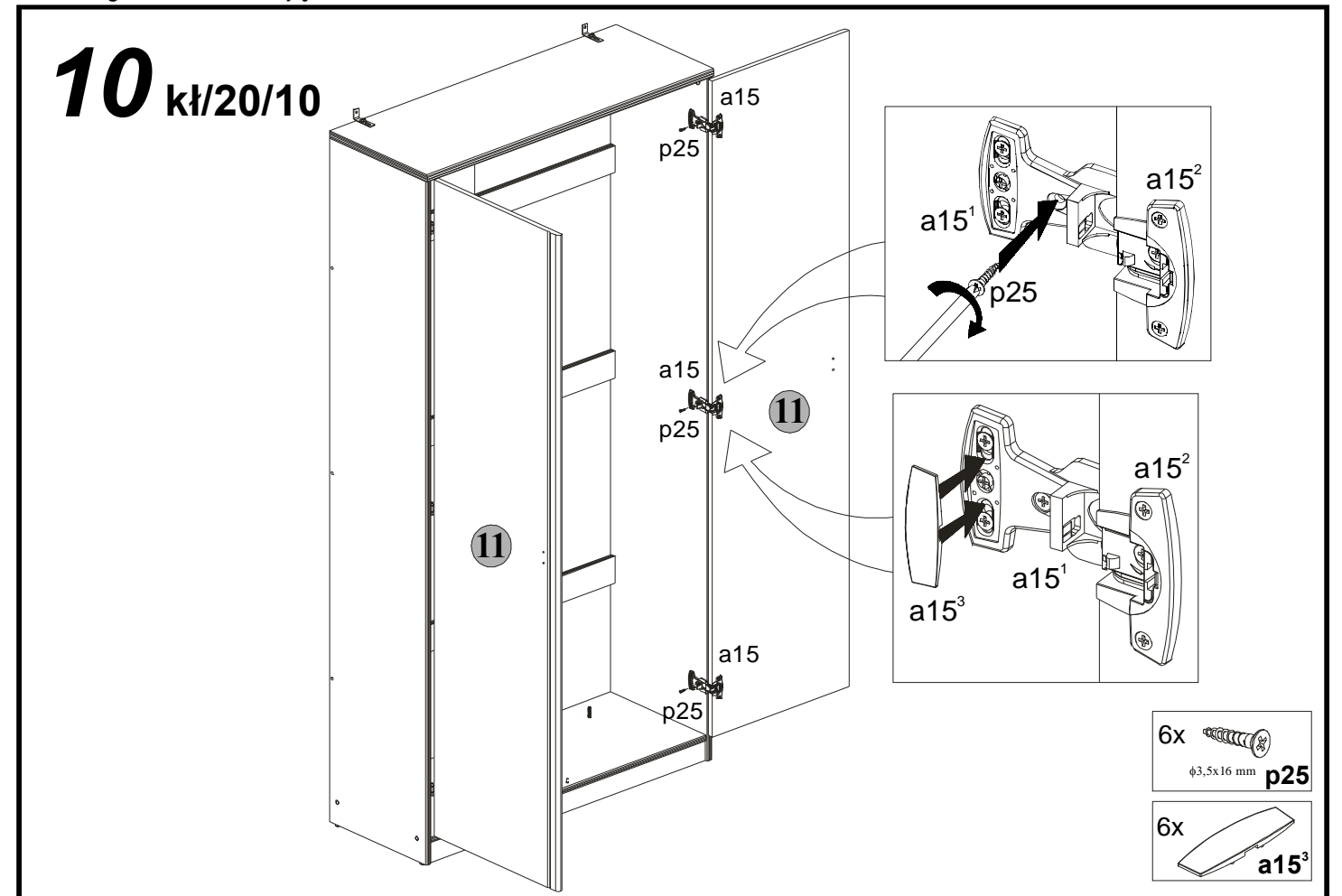

Podczas montażu  
postępować  
zgodnie z instrukcją.

While assembling  
follow  
the instruction.

Montage laut  
der Aufbauanleitung  
durchführen.

# 8 kł/20/10

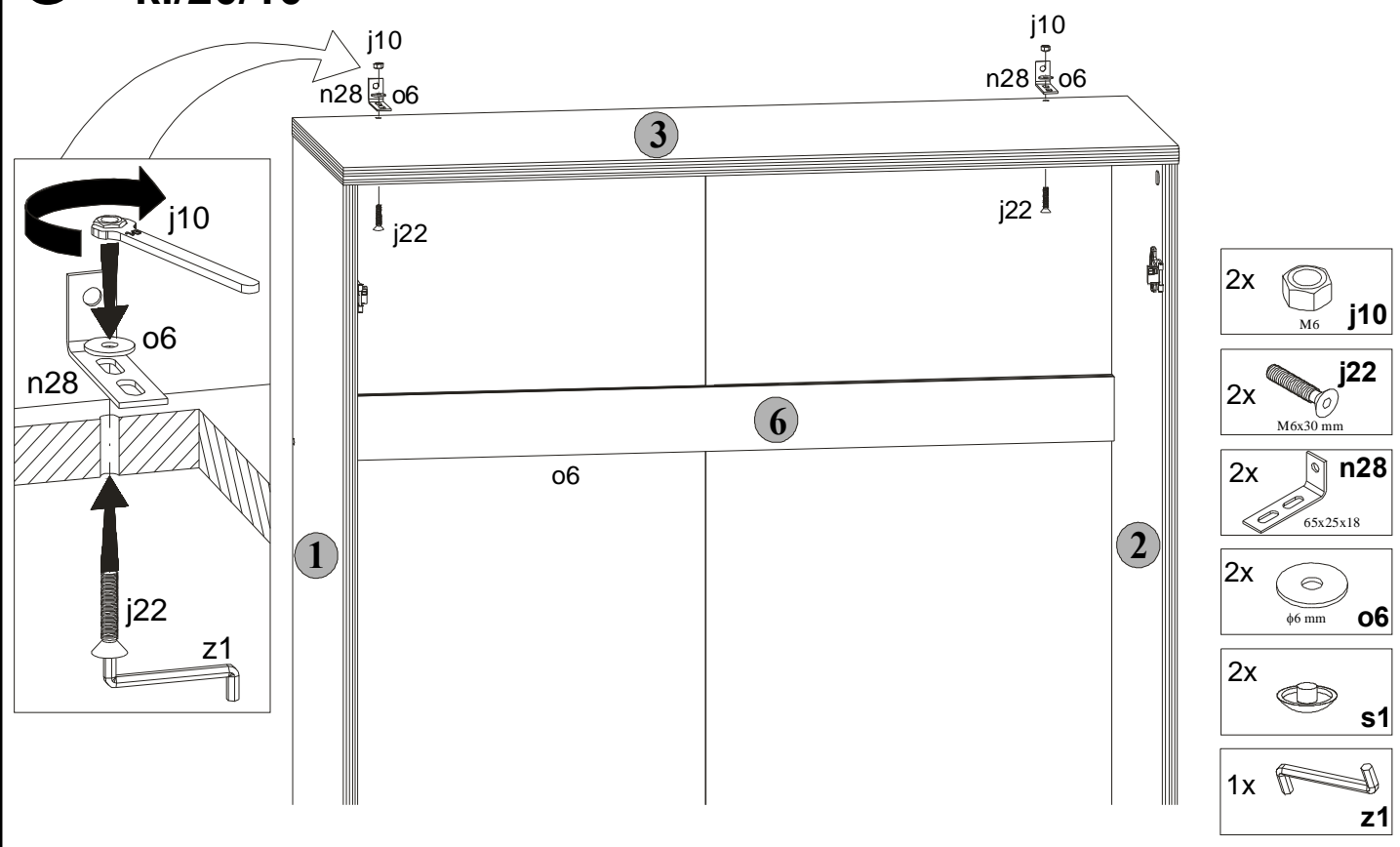

Podczas montażu  
postępować  
zgodnie z instrukcją.

While assembling  
follow  
the instruction.

Montage laut  
der Aufbauanleitung  
durchführen.

# 2 kł/20/10

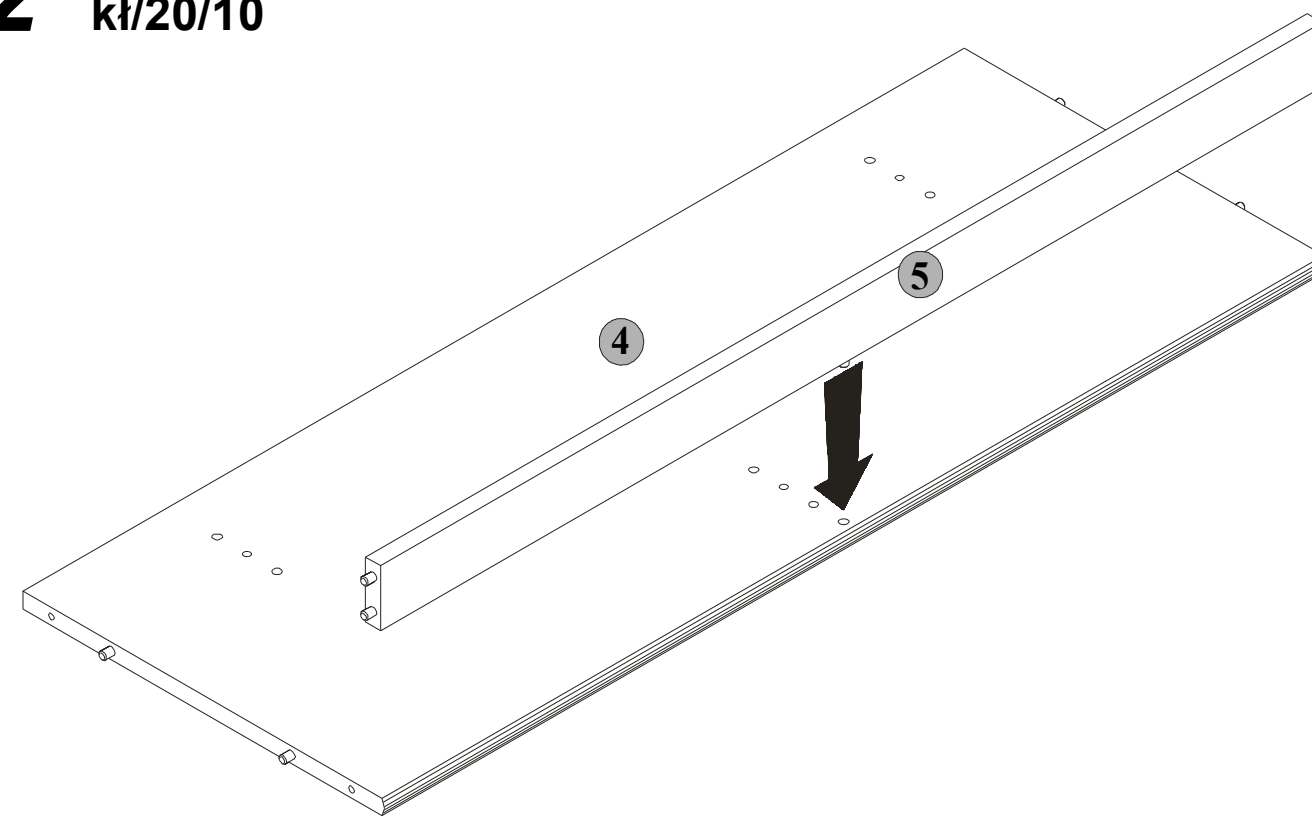

# 9 kł/20/10

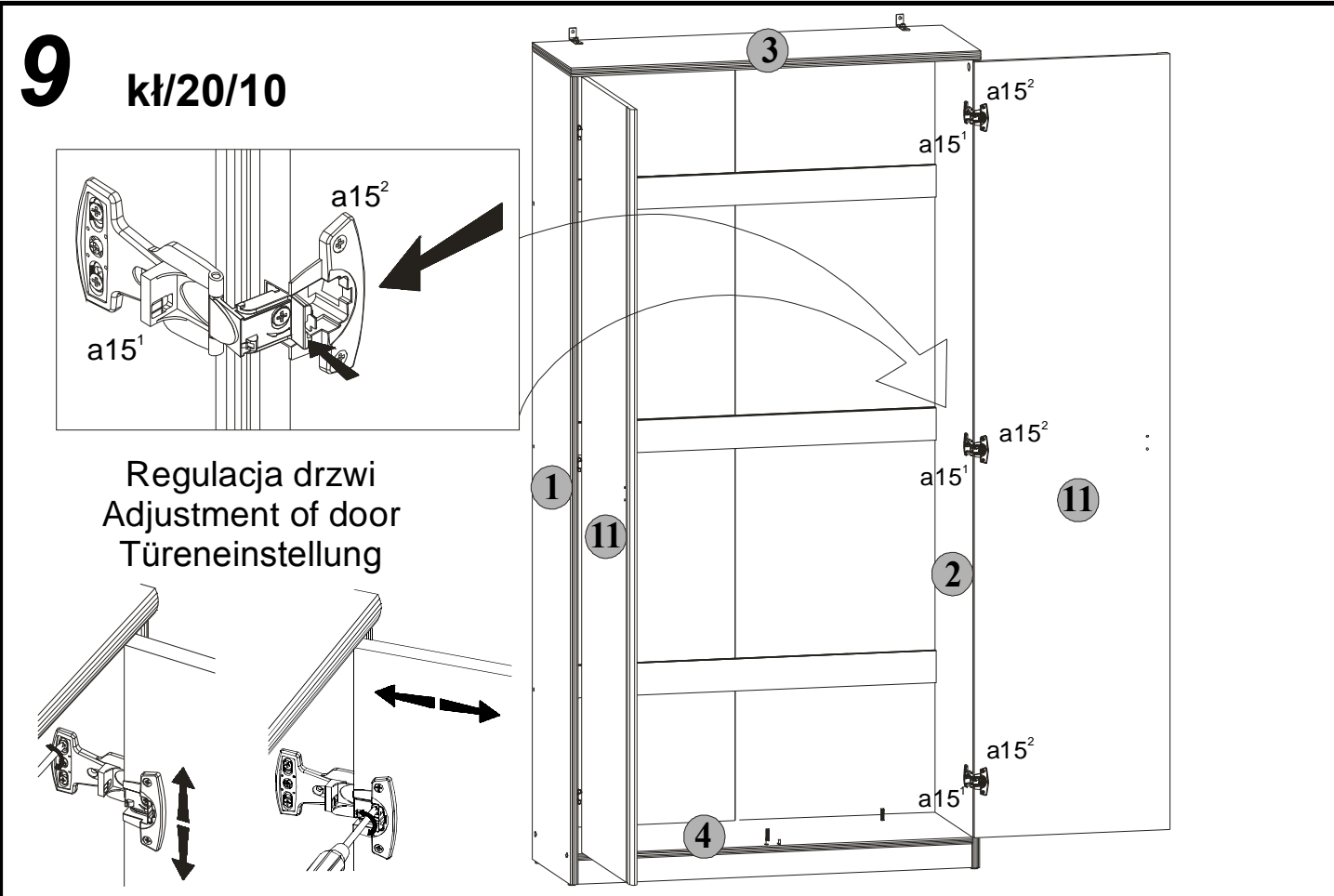

# 3 kł/20/10

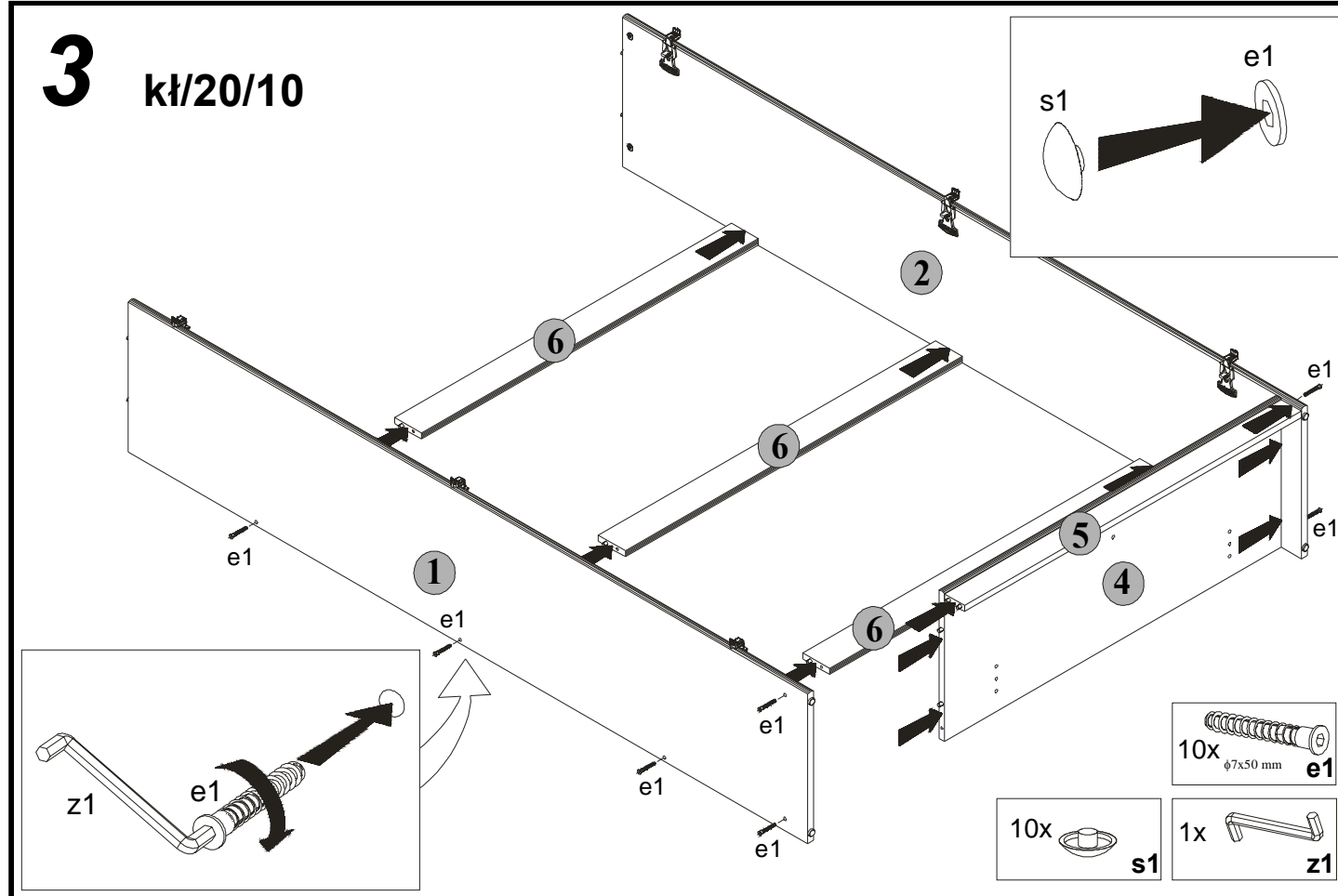

Podczas montażu  
postępować  
zgodnie z instrukcją.

While assembling  
follow  
the instruction.

Montage laut  
der Aufbauanleitung  
durchführen.

# 4

kł/20/10

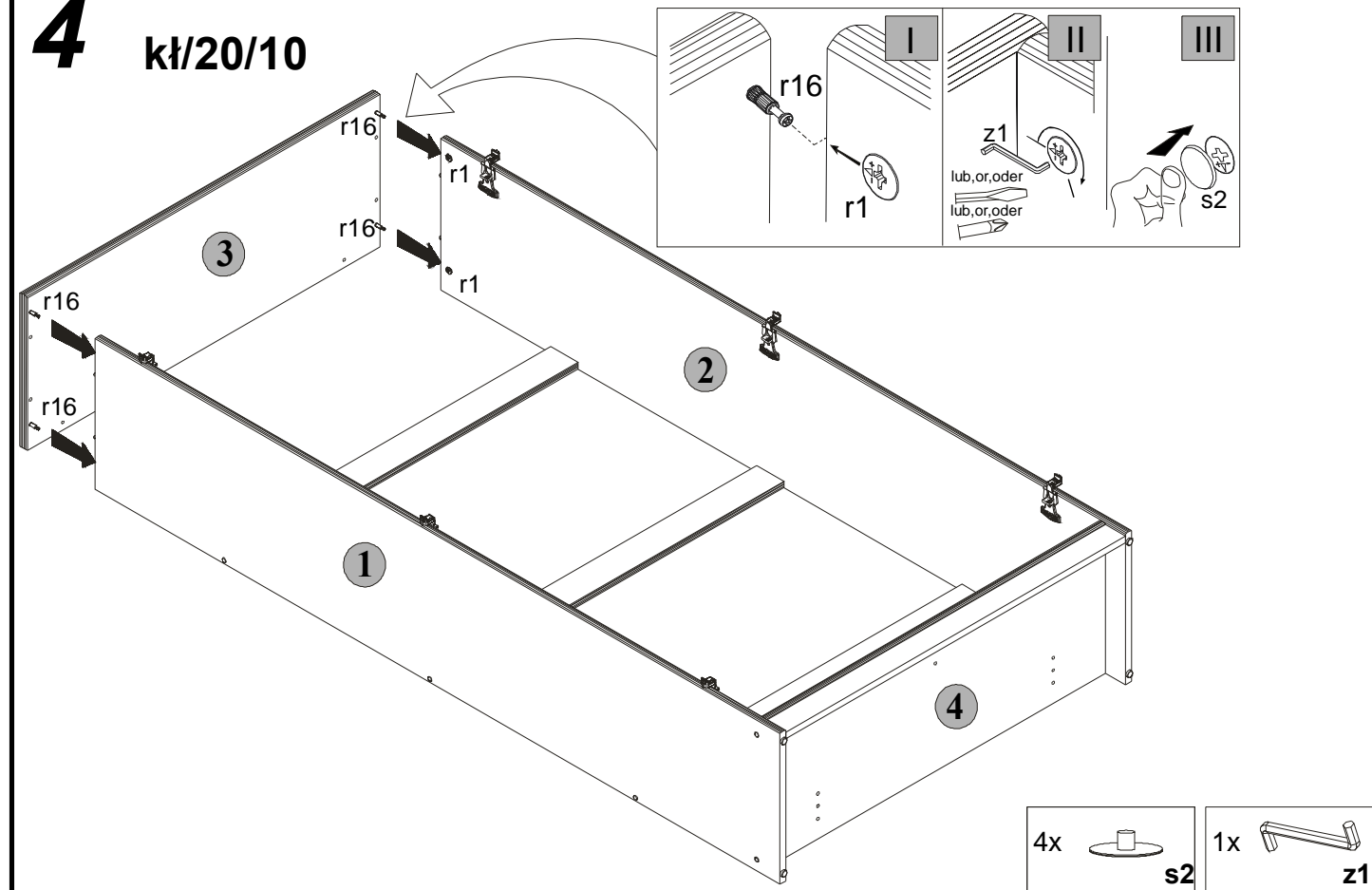

Podczas montażu  
postępować  
zgodnie z instrukcją.

While assembling  
follow  
the instruction.

Montage laut  
der Aufbauanleitung  
durchführen.

# 6

kł/20/10

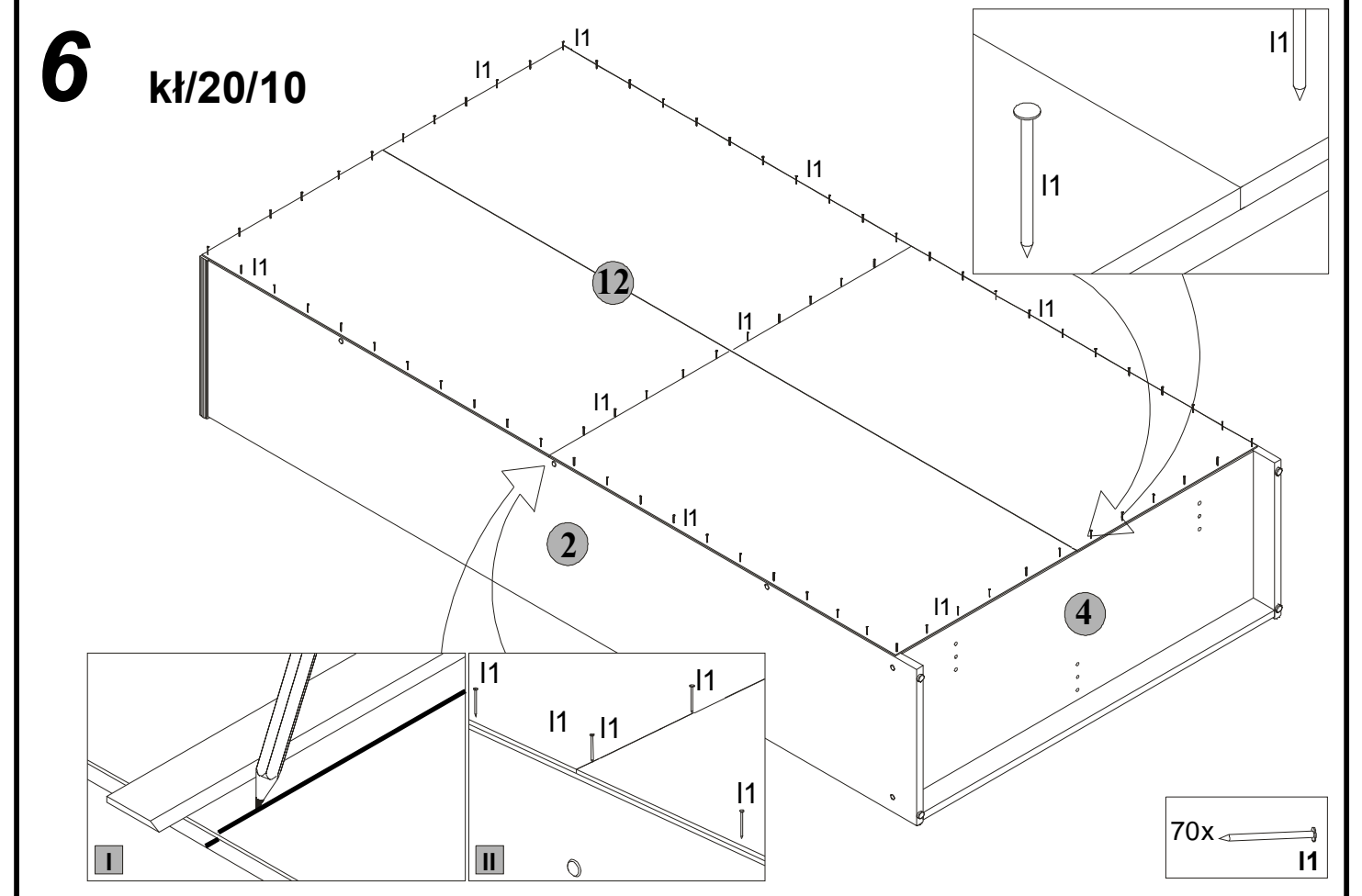

# 5

kł/20/10

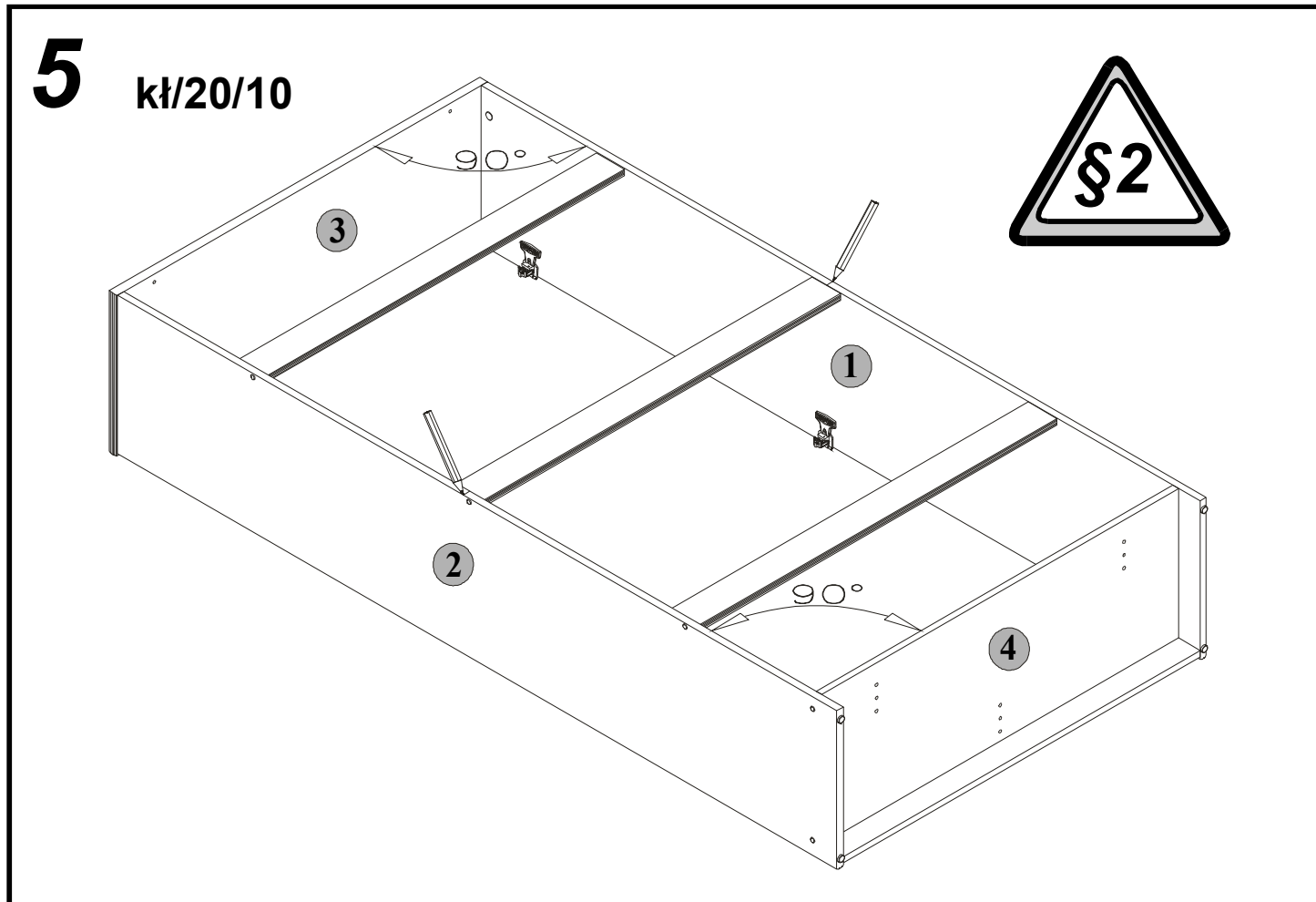

# 7

kł/20/10

