

14 SZF/2d/2s

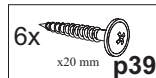

15 SZF/2d/2s

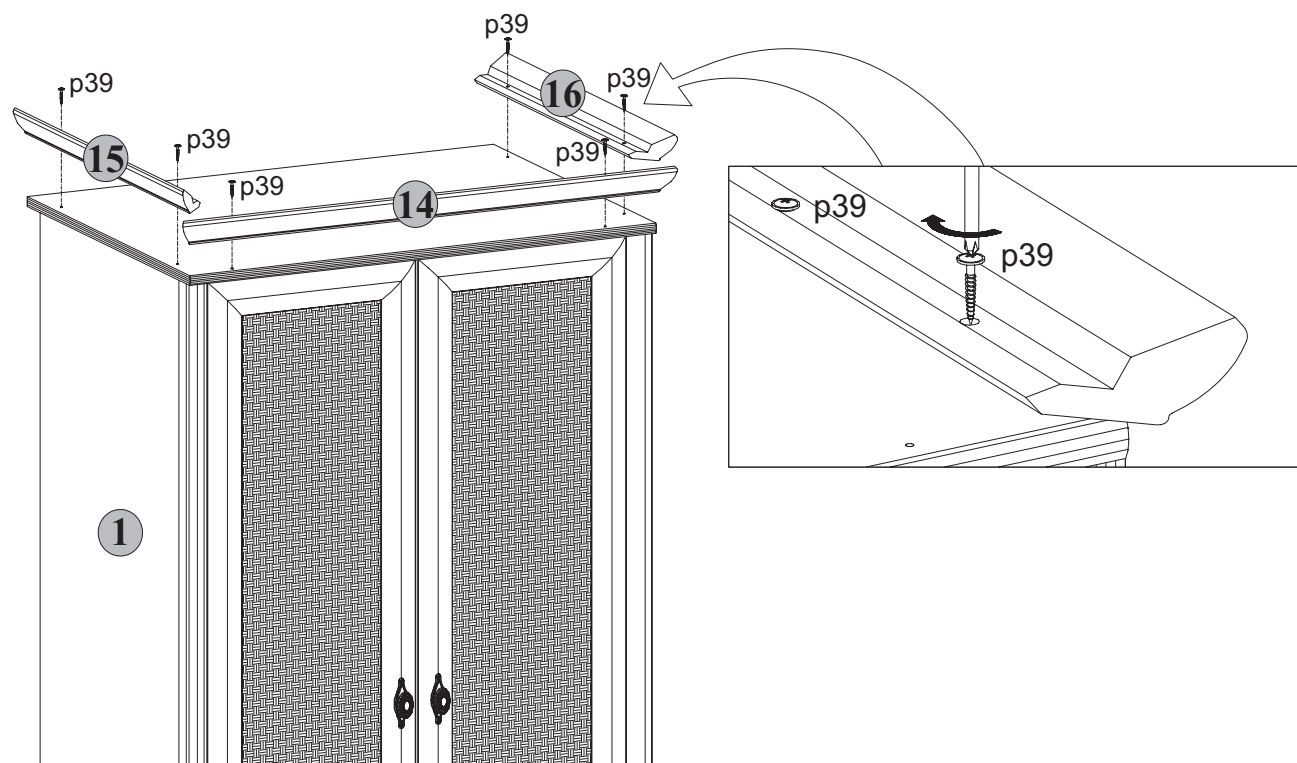

Uwaga: Przymocować segment do ściany. Nie przestrzeganie w/w zalecenia może grozić przewróceniem się segmentu podczas użytkowania.
Warning: Fasten section to the wall. Not following the above instruction may cause falling down the section while using it.
Hinweis: Segment an der Wand fixieren. Nicht Beachten dieser Anweisung kann zum Umkippen der Möbel führen.

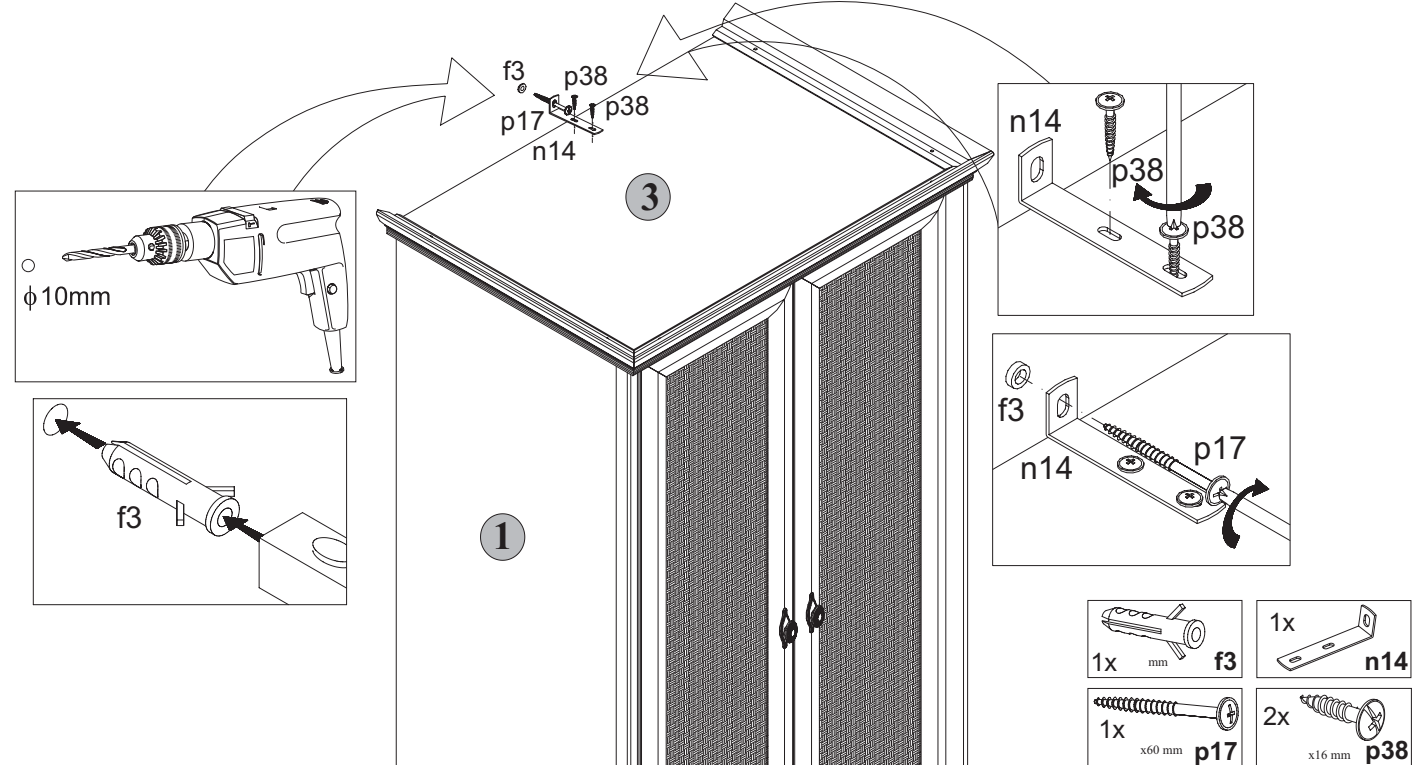

INSTRUKCJA UŻYTKOWANIA MEBLA FURNITURE USE INSTRUCTION WICHTIGE HINWEISE

RETRO SZF/2d/2s



Producent:
BLACK RED WHITE S.A.
 UL. KRZESZOWSKA 63
 23-400 BIŁGORAJ

194,5x80x58,5/cm/
 199x85x61/cm/

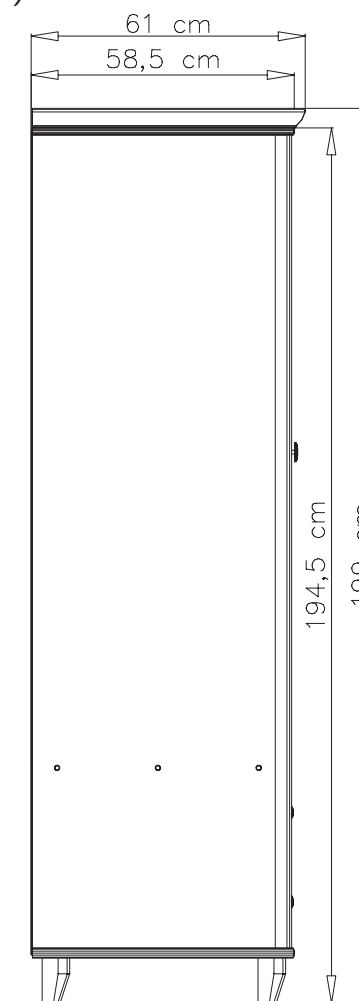
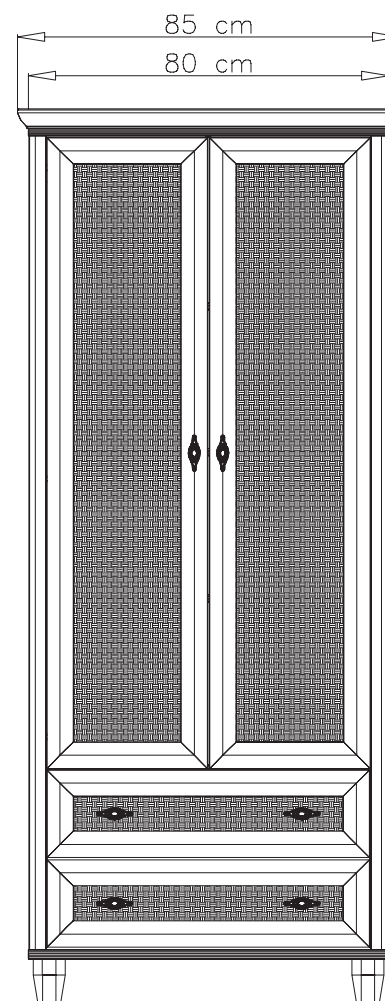
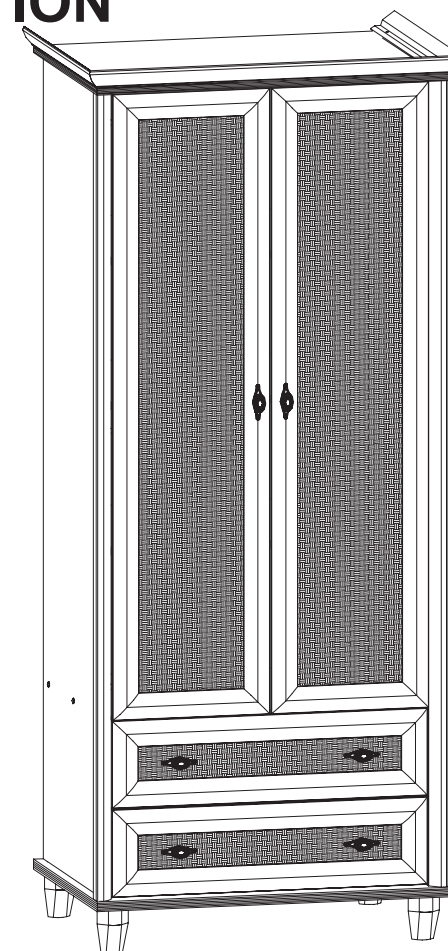

Paczki:/Packages:/Paketen:

- Korpus1/Body1/Möbelkorps1
- Korpus2/Body2/Möbelkorps2
- Fronty1/Fronts1/Möbelfronten1
- Fronty2/Fronts2/Möbelfronten2
- Listwy/Slates/Zierleisten
- Akcesoria/Accessories/Zubehör

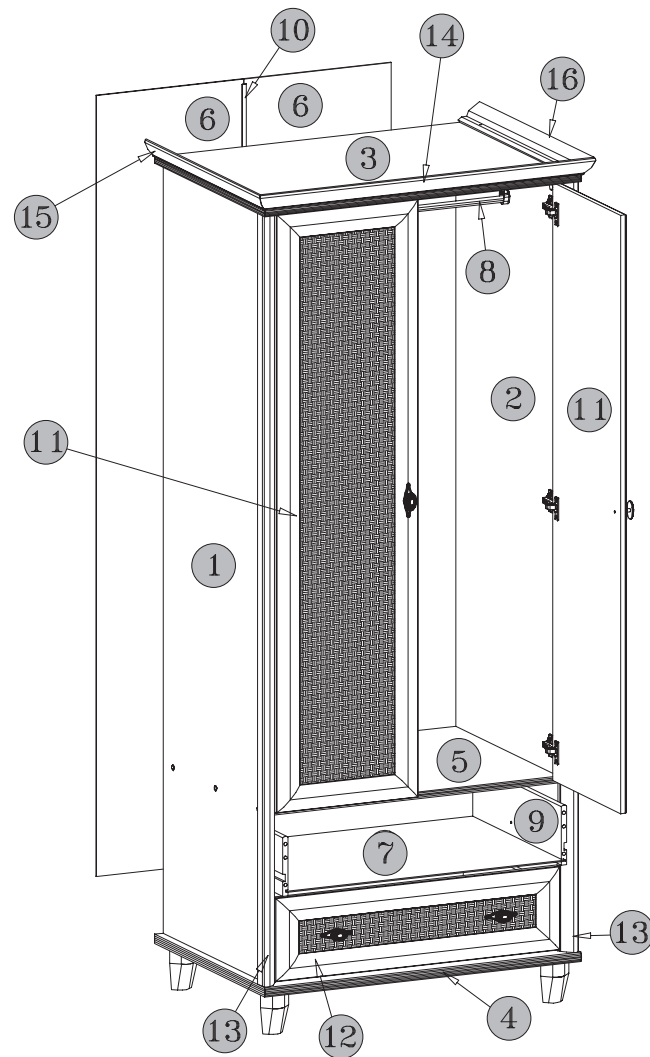

Korpus1/Body1/Möbelkorps1

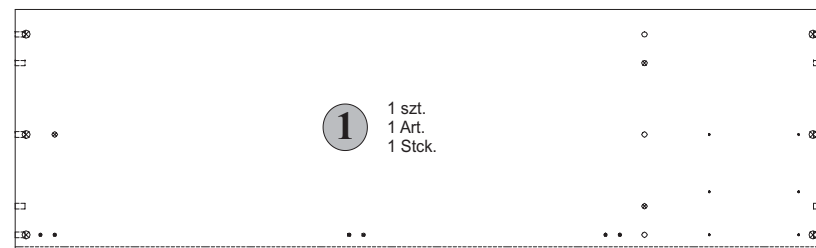

1 1 szt.
1 Art.
1 Stck.

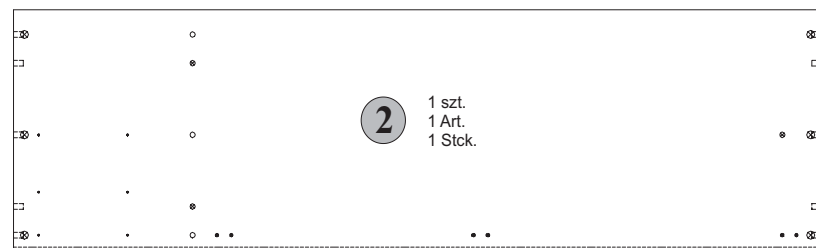

2 1 szt.
1 Art.
1 Stck.

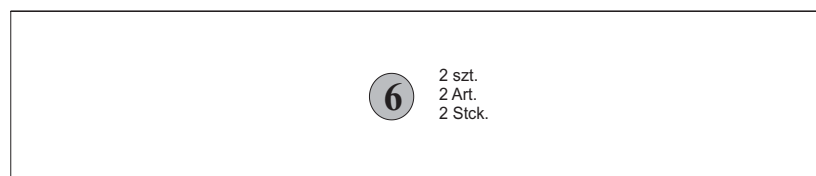

6 2 szt.
2 Art.
2 Stck.



9 2 szt.
2 Art.
2 Stck.



10 1 szt.
1 Art.
1 Stck.

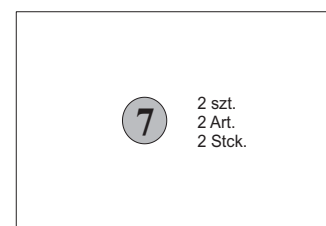

7 2 szt.
2 Art.
2 Stck.



8 1 szt.
1 Art.
1 Stck.

Symbol elementu Element symbol Elementeszeichen	Wymiary Measurements Ausmaß	Kod Code Kode
1	1806x540	RE1-121
2	1806x540	RE1-122
6	1830x375	RE1-918
7	480x702	RE1-920
8	717	DR-717
9	1676x140	RE1-515
10	1805	LH-1805

Podczas montażu
postępować
zgodnie z instrukcją.

While assembling
follow
the instruction.

Montage laut
der Aufbauanleitung
durchführen.

12 SZF/2d/2s

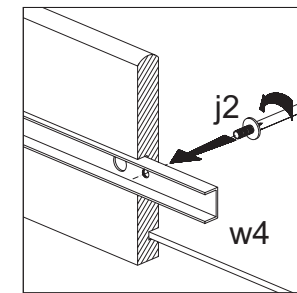
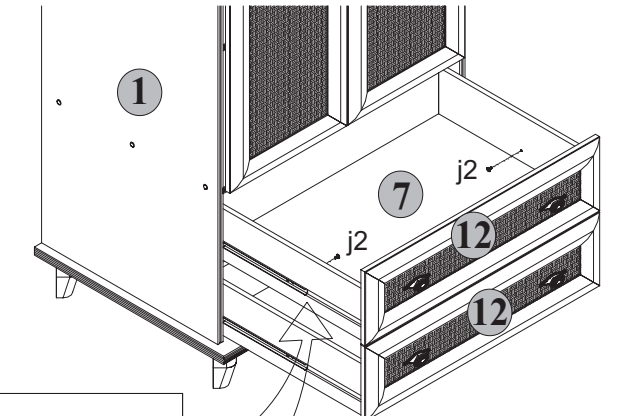
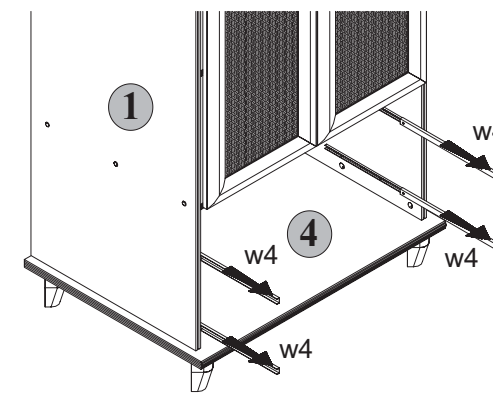

4x M4x9 mm j2

13 SZF/2d/2s

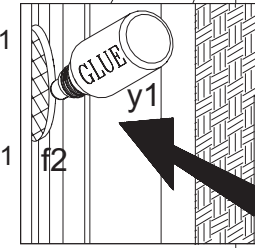
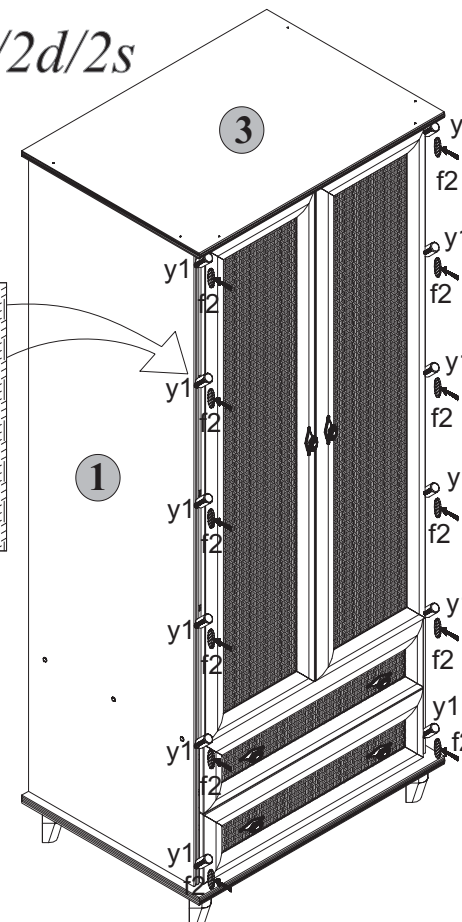
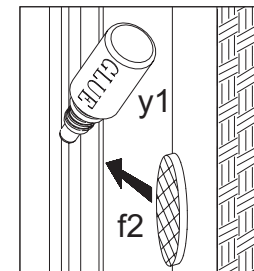

12x f2

1x y1

Podczas montażu
postępować
zgodnie z instrukcją.

While assembling
follow
the instruction.

Montage laut
der Aufbauanleitung
durchführen.

10 SZF/2d/2s

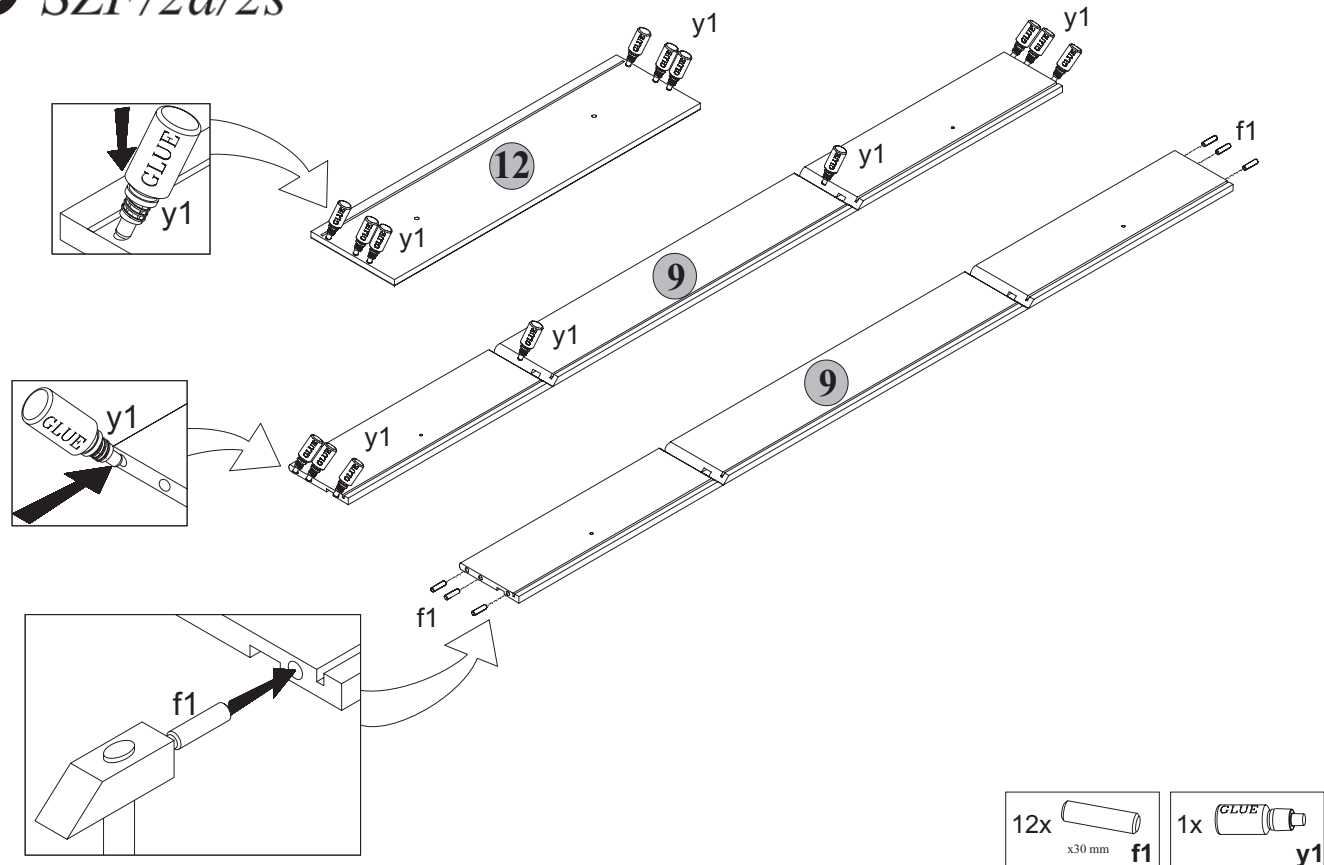

Korpus2/Body2/Möbelkorps2

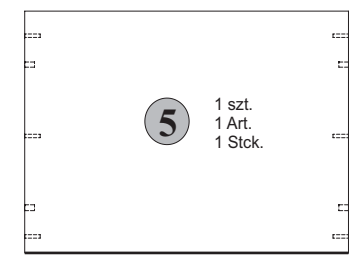
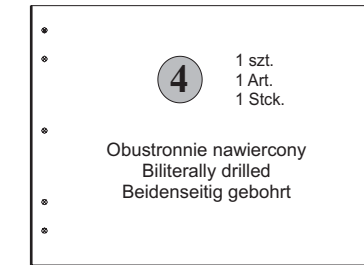
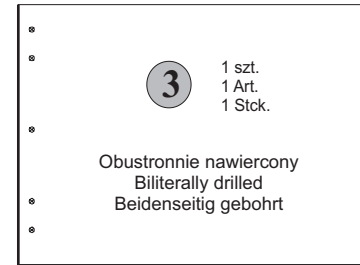

Symbol elementu	Wymiary	Kod
Element symbol	Measurements	Code
Elementeszeichen	Ausmaß	Kode
3	800x582	RE1-214
4	800x582	RE1-215
5	724x540	RE1-312

Fronty1/Fronts1/Möbelfronten1

Fronty/Fronts/Möbelfronten

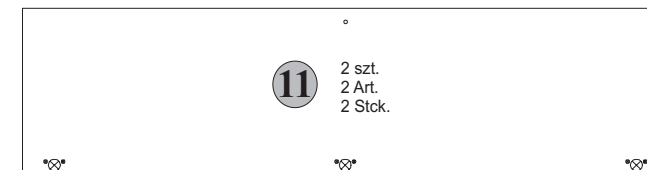

Symbol elementu	Wymiary	Kod
Element symbol	Measurements	Code
Elementeszeichen	Ausmaß	Kode
11	1402x358	RE1-023

11 SZF/2d/2s

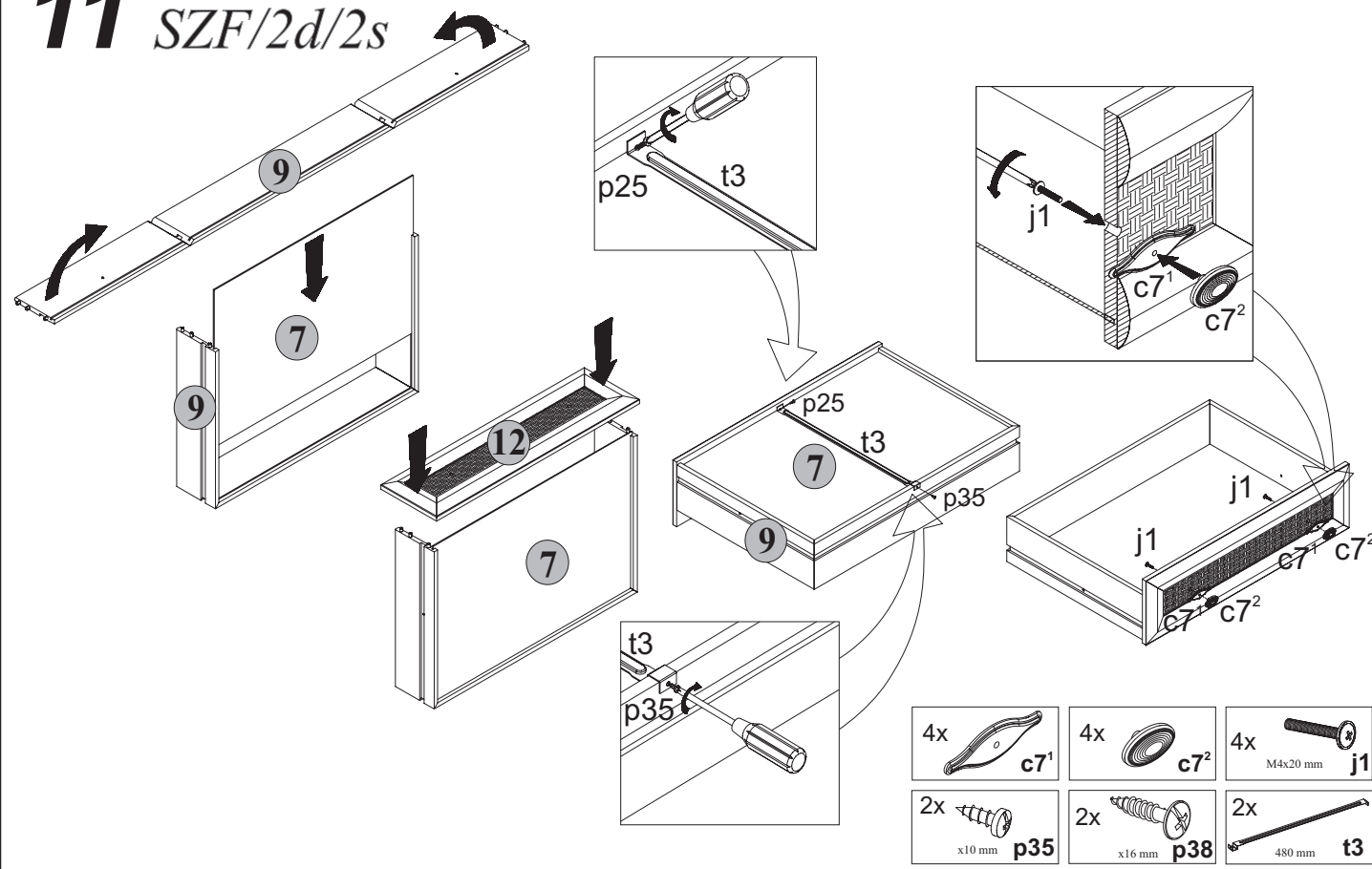

Fronty2/Fronts2/Möbelfronten2

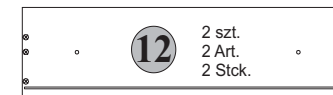

Symbol elementu	Wymiary	Kod
Element symbol	Measurements	Code
Elementeszeichen	Ausmaß	Kode
12	718x196	RE1-003

Listwy/Slates/Zierleisten

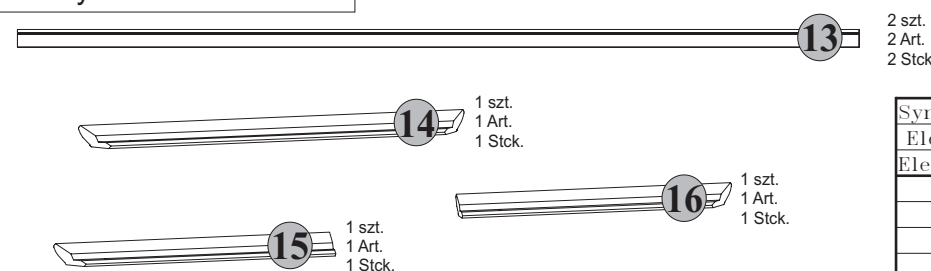











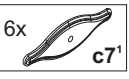

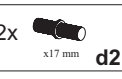
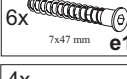

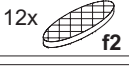
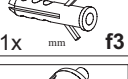

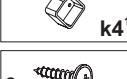

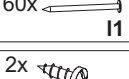
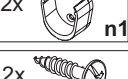
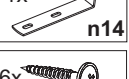

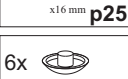
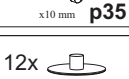
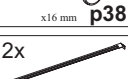

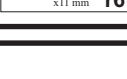

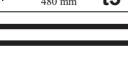
Symbol elementu	Wymiary	Kod
Element symbol	Measurements	Code
Elementeszeichen	Ausmaß	Kode
13	1806x38	RE1-577
14	849x66	RE1-591
15	606x66	RE1-587
16	606x66	RE1-588

INFORMACJA!
Szanowny Kliencie, w przypadku zgłaszania reklamacji, prosimy posługiwać się numerem kodu podanym w instrukcji montażu. Wszelkie uwagi i reklamacje należy zgłaszać do punktu zakupu mebla.
Uwaga! Nie montować elementów, jeżeli zostaną zauważone wady lub uszkodzenia tych elementów.

INFORMATION!
Dear client, in case of complaining, please use the code number given in the assembly instruction. Any comments and complaints should be reported at the furniture purchase outlet.
Note! Do not use any parts showing any faults or marks of damage

HINWEIS!
Sehr geehrte Kunden, im Falle einer Reklamation, geben Sie bitte die in der Montageanleitung erwähnte Code-Nummer an. Mit allen diesbezüglichen Fragen und Reklamationen wenden Sie sich bitte an ihren Verkäufer.
Vorsicht! Falls Sie irgendwelche beschädigte Teile bemerken verzichten Sie bitte auf die Montage.

Akcesoria/ Accessories/ Zubehör					
6x 	6x 	6x 	6x 	2x 	
6x 	24x 	12x 	1x 	4x 	4x 
4x 	4x 	60x 	2x 	1x 	14x 
8x 	2x 	2x 	2x 	6x 	12x 
12x 	6x 	12x 	2x 	4x 	1x 
12x 	6x 	12x 	2x 	4x 	1x 

Do montażu potrzebne są:
You need for fitting-up:
Zur Montage werden Sie brauchen:

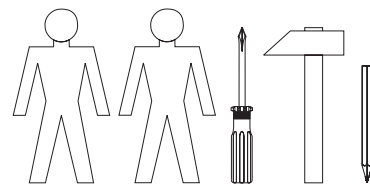

ZASADY UŻYTKOWANIA I KONSERWACJI MEBLI

1. Meble należy użytkować w pomieszczeniach suchych i zabezpieczonych przed szkodliwymi wpływami atmosferycznymi.
2. Montaż mebli należy przeprowadzić zgodnie z instrukcją montażu, przy użyciu odpowiednich narzędzi.
3. Miejsce montażu mebli w miarę możliwości powinno odbywać się jak najbliżej miejsca stałego ustawienia.
4. Przy ustawianiu mebli należy je wypoziomować.
5. Przemieszczanie mebli winno być dokonywane poprzez przenoszenie bez dodatkowego obciążenia.
Uwaga: przesuwanie, ciągnięcie mebli grozi trwałym ich uszkodzeniem.
Podczas przenoszenia należy chwytać za elementy pionowe mebla tj.: boki, nogi.
Nie wolno chwytać za części poziome, które mogą być podatne na uszkodzenia tj.: blaty, szuflady, itp.
6. Nie należy nadmiernie obciążać mebli gdyż grozi to ich trwałym uszkodzeniem.
7. W trakcie użytkowania mebli, w razie potrzeby należy sprawdzić stan połączeń mimośrodowych.
8. Powierzchnię mebli należy czyścić wilgotną szmatką lub papierowym ręcznikiem. Nie używać chemicznych środków czystości.



RULES FOR FURNITURE USE AND MAINTENANCE

1. Furniture should be used in dry and protected against harmful atmospheric effects rooms.
2. Furniture assembly should follow the assembly instruction with use of proper tools.
3. The place of furniture assembly should take place as close to the place of permanent arrangement as possible, if at all possible.
4. While arranging furniture, they should be set horizontally.
5. Moving furniture should be made by moving it without any additional load.
Warning: moving, pulling furniture may cause permanent damage.
While moving you should seize vertical elements of furniture i.e. sides, legs, etc.
You must not seize horizontal parts that can be easily damaged i.e. table tops, drawers, etc.
6. You must not weigh down furniture excessively because it may cause permanent damage to the furniture.
7. While using furniture check the state of eccentric joints if needed.
8. The surface of furniture should be cleaned with a damp cloth or paper towel. Do not use cleansing agents.



HINWEISE ZUR NUTZUNG UND PFLEGE DER MÖBEL

1. Die Möbel nur in trockenen, von den schädigenden atmosphärischen Einwirkungen geschützten Räumen nutzen.
2. Die Montage mit laut Aufbauanleitung geeigneten Werkzeugen durchführen.
3. Die Montagestelle soll sich möglichst nah der Nutzstelle befinden.
4. Die Möbel sollen waagrecht aufgestellt werden.
5. Beim Umstellen sollen die Möbel entladen werden.
Vorsicht: beim Verschieben können die Möbel beschädigt werden.
Beim Tragen nur vertikale Teile greifen. Waagerechte Elemente wie Blätter, Schubladen, können beschädigt werden.
6. Überlasten der Möbel kann zur Schädigungen führen.
7. Zeitweise außermittige Verbindungen kontrollieren.
8. Die Oberfläche der Möbel mit feuchtem Lappen oder Papierhandtuch reinigen.
Keine chemischen Reinigungsmittel gebrauchen.

Podczas montażu
postępować
zgodnie z instrukcją.

While assembling
follow
the instruction.

Montage laut
der Aufbauanleitung
durchführen.

8 SZF/2d/2s

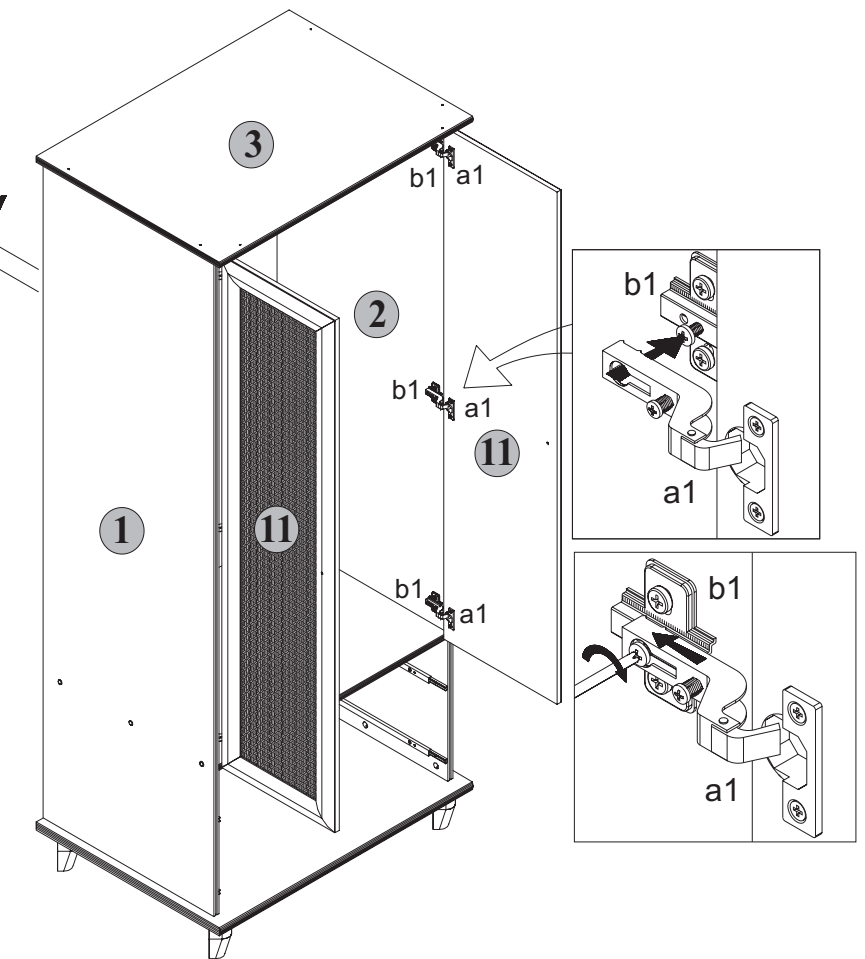
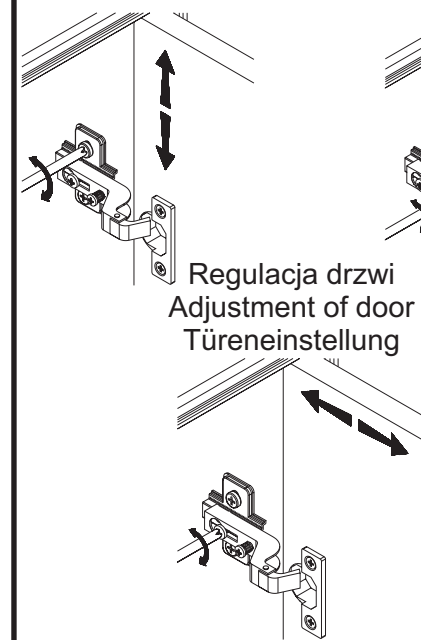

9 SZF/2d/2s

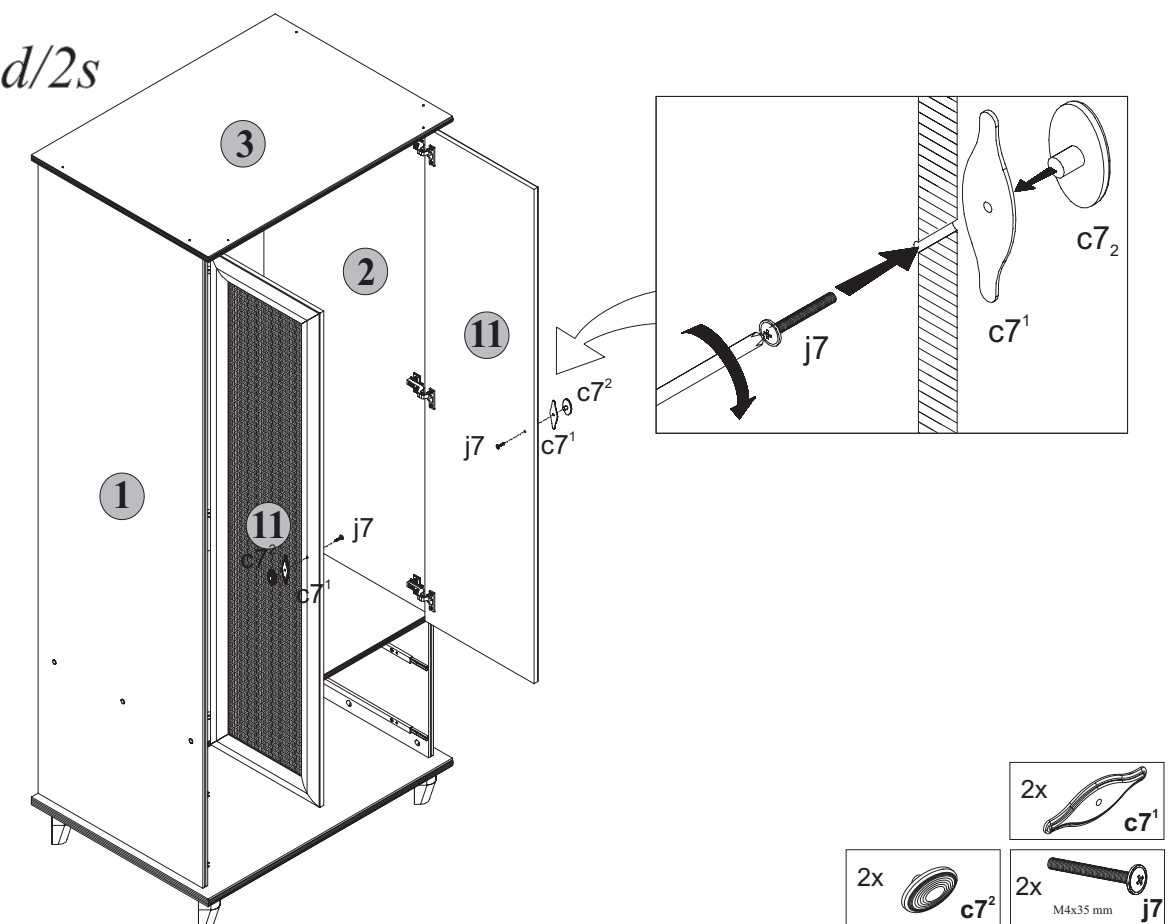

Podczas montażu
postępować
zgodnie z instrukcją.

While assembling
follow
the instruction.

Montage laut
der Aufbauanleitung
durchführen.

6 SZF/2d/2s



Uwaga: Przed przybiciem pilśni sprawdzić, czy przekątne są równe.
Warning: Before nailing a fiberboard, make sure that the diagonals are equal.
Hinweis: Vor der Anbringung der Holzfaserplatte überprüfen Sie, ob die Diagonale stimmen.

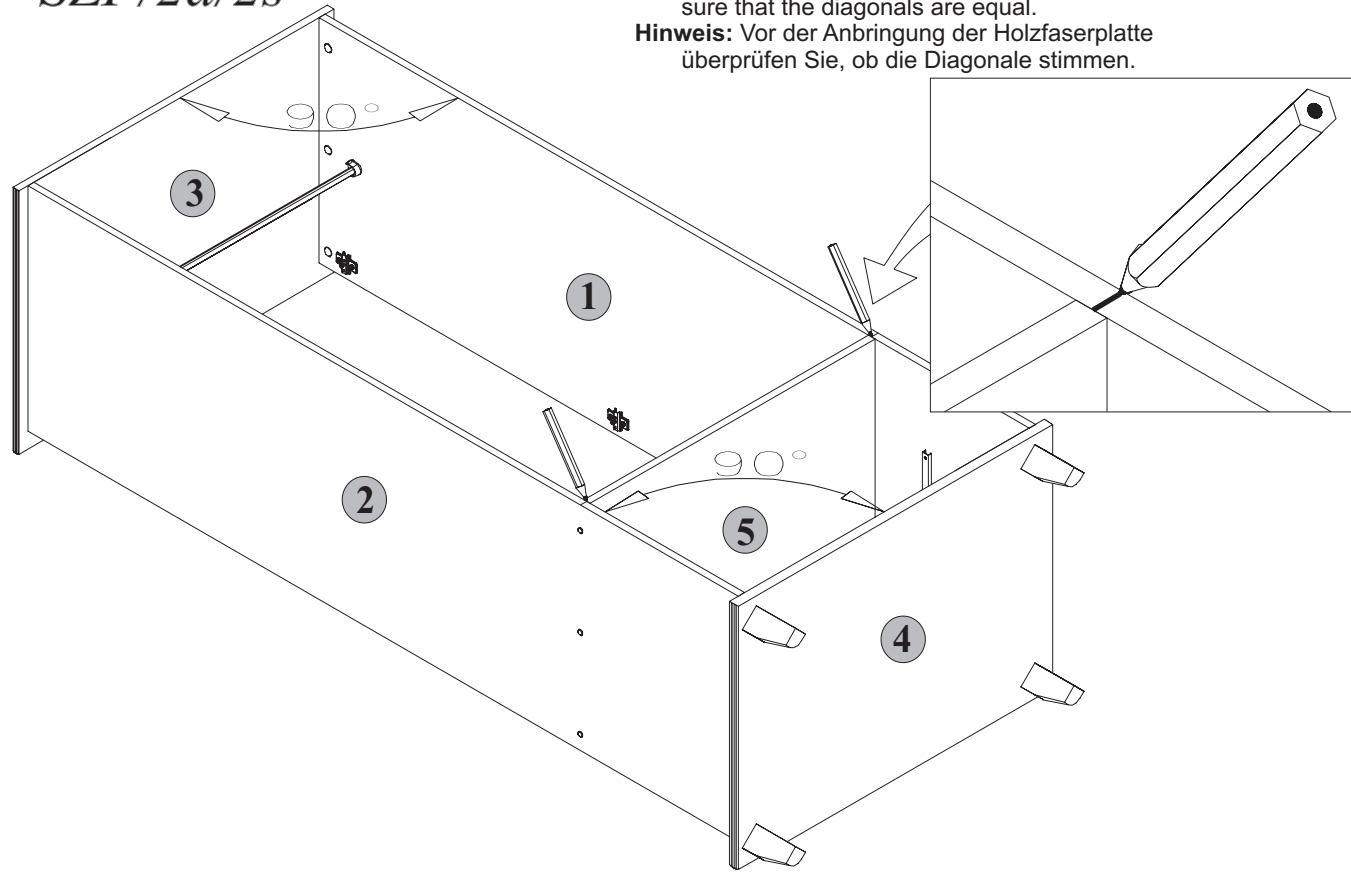

7 SZF/2d/2s

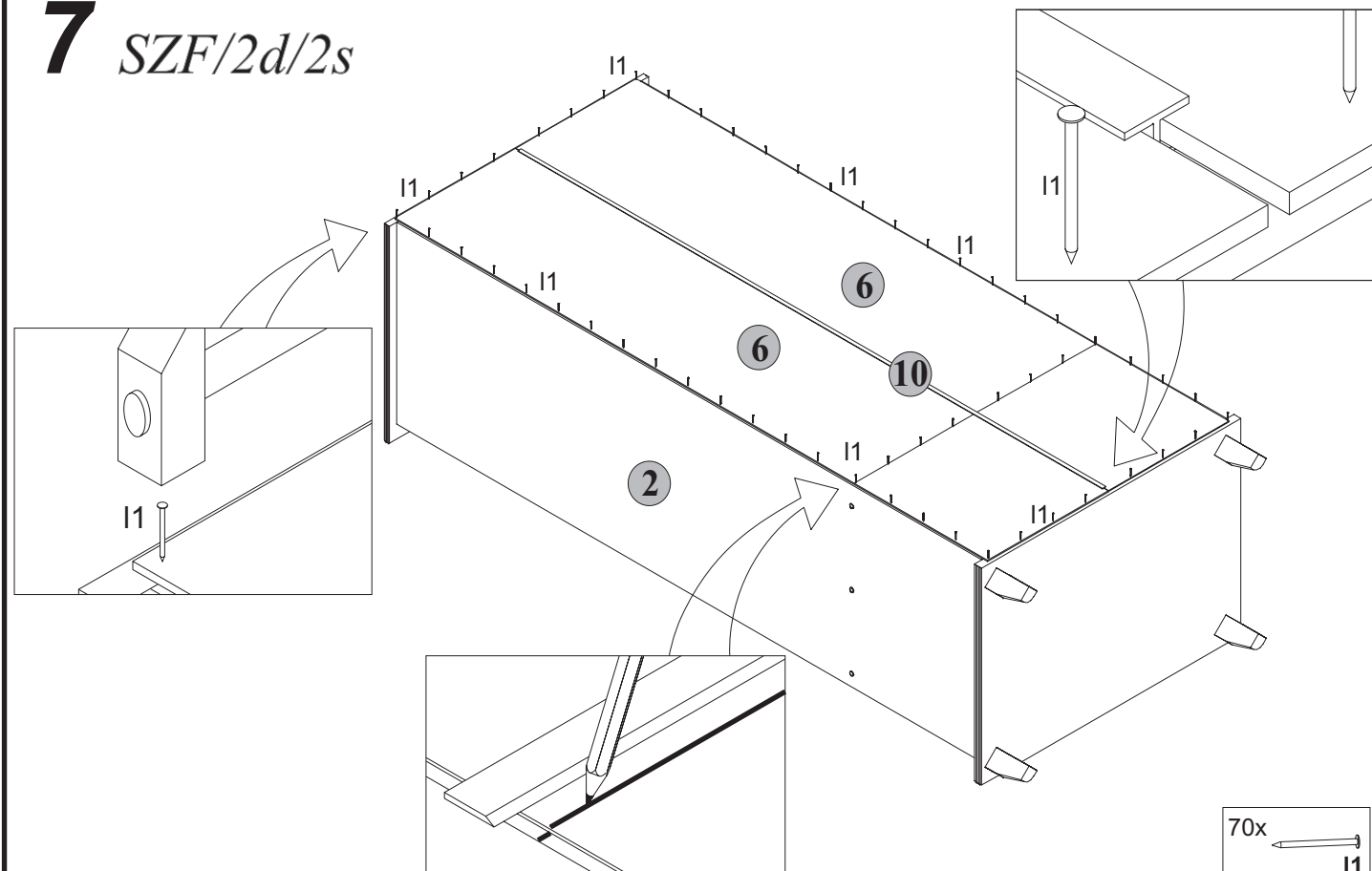

INSTRUKCJA MONTAŻU FITTING-UP INSTRUCTION AUFBAUANLEITUNG

1 SZF/2d/2s



Uwaga: W przypadku stwierdzenia, że któryś z kołczków wystaje z otworu na długość większą niż 10 mm, należy go dobić, wymienić lub skrócić, gdyż może on spowodować przy składaniu uszkodzenie boku.
Warning: When you notice that one of the pins sticks out of a hole more than 10 mm, you should hammer it, change or shorten because it may cause damage to a side while assembling.
Hinweis: Falls Sie feststellen, dass einer der Dübelchen mehr als 10 mm hervorsteht, soll er tiefer eingeschlagen, ausgetauscht oder verkürzt werden. Die Anweisung soll befolgt werden, anderenfalls kann es zur Schädigung der Möbelseiten kommen.

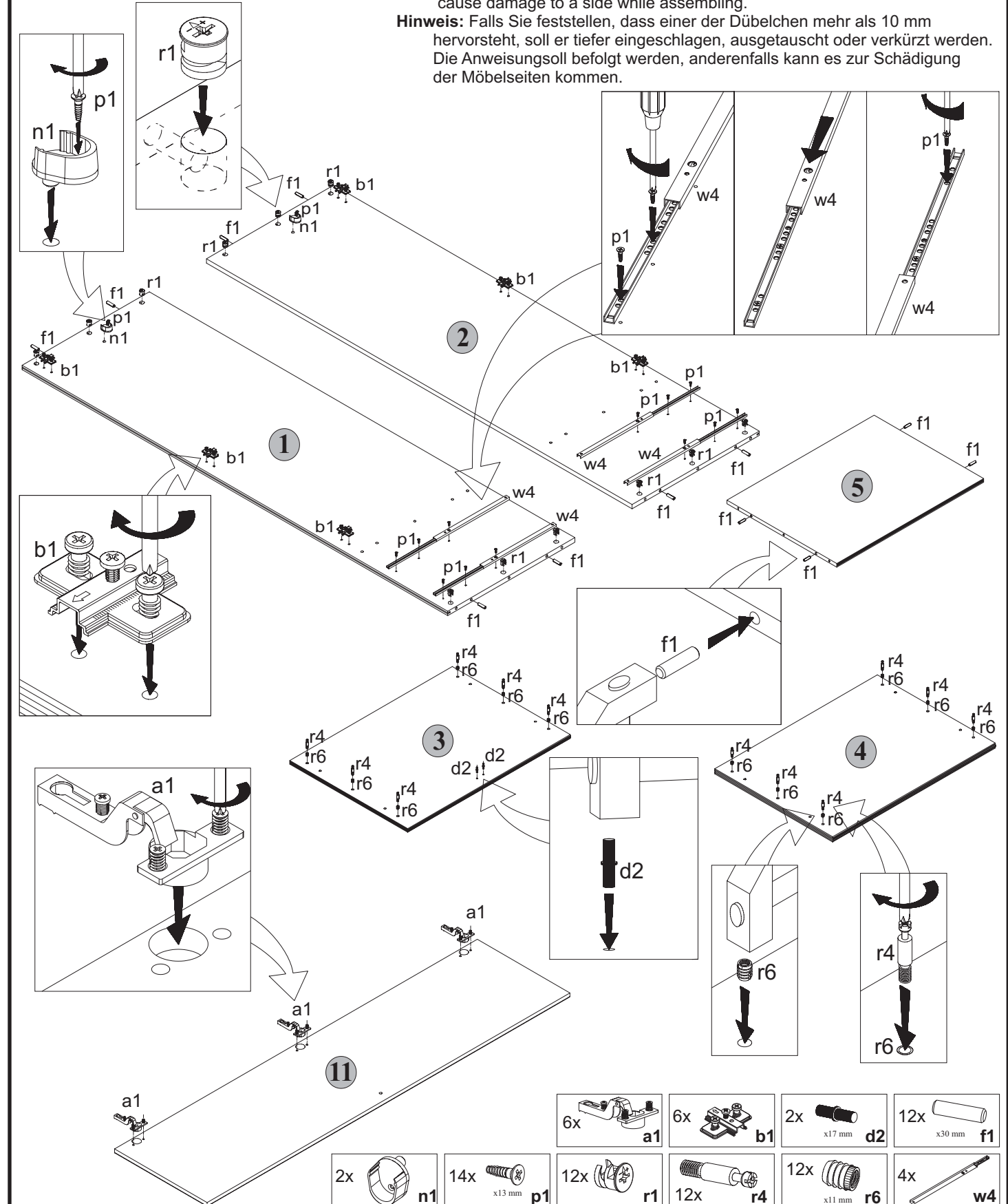

Podczas montażu
postępować
zgodnie z instrukcją.

While assembling
follow
the instruction.

Montage laut
der Aufbauanleitung
durchführen.

2 SZF/2d/2s

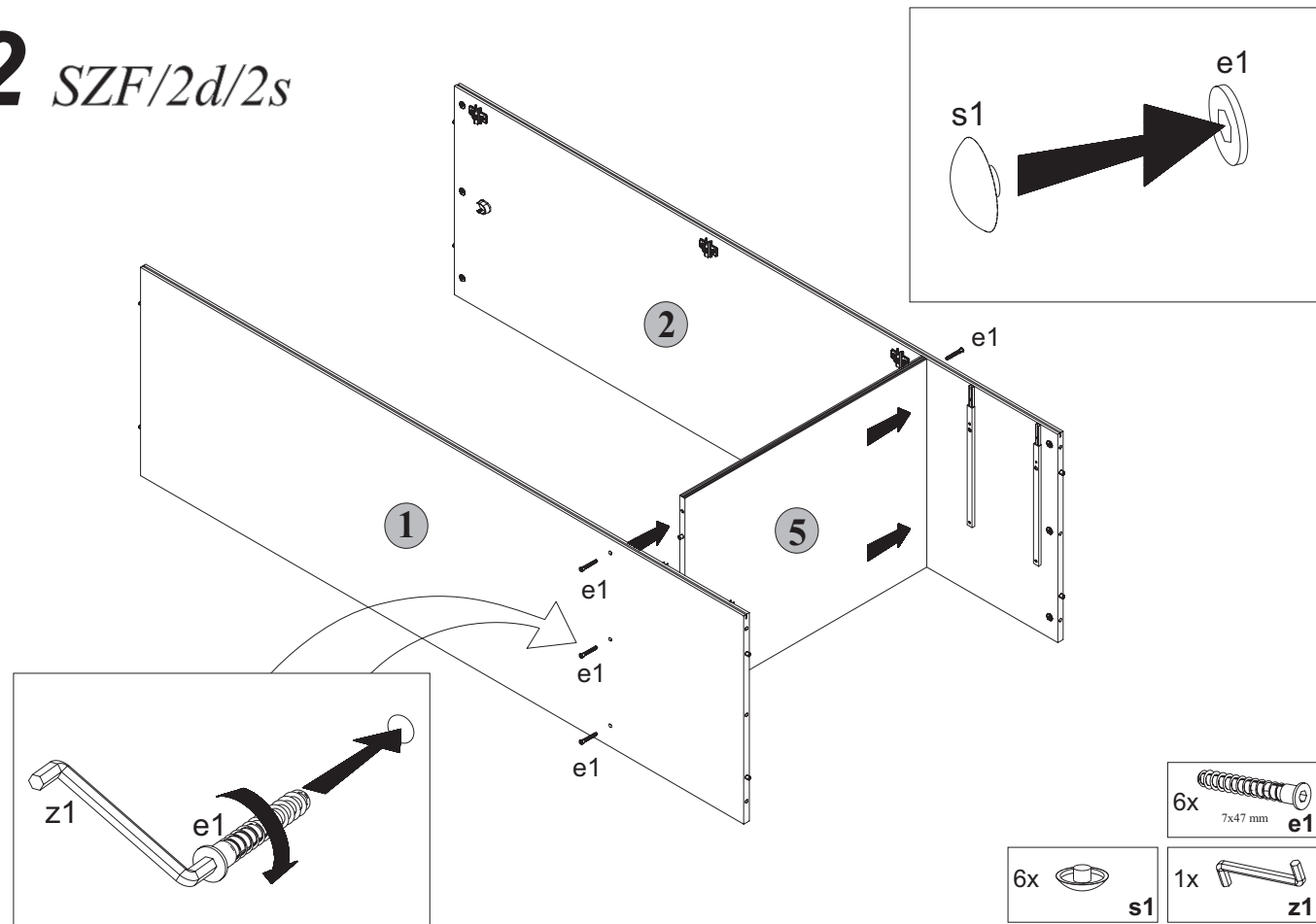

4 SZF/2d/2s

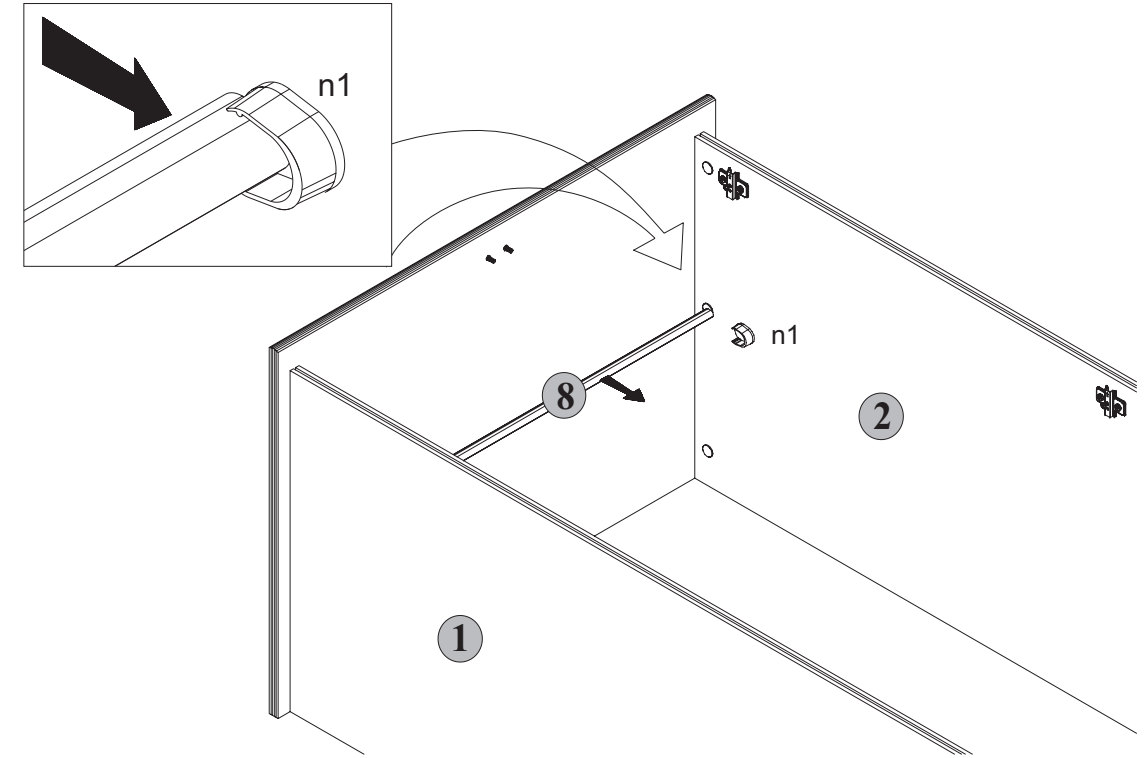

3 SZF/2d/2s

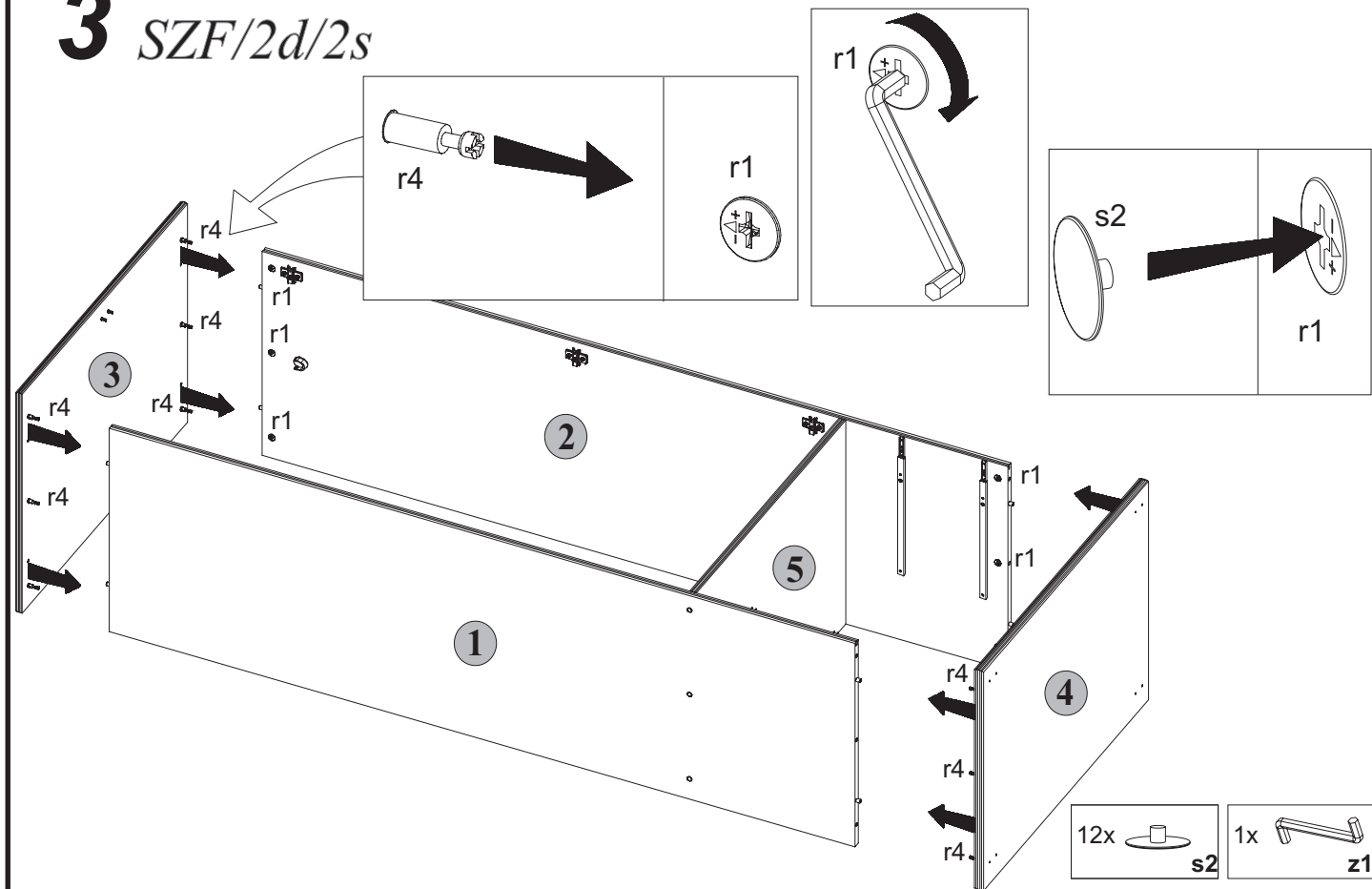

5 SZF/2d/2s

