

| A | B | C | D | A | B | C | D | | |
|----|---------|------|-----|-----|----|----------|------|-----|-----|
| 1 | S73-005 | 1496 | 188 | 5/5 | 13 | S73-408 | 1464 | 50 | 2/5 |
| 2 | S73-007 | 1524 | 496 | 5/5 | 14 | S73-414 | 1464 | 80 | 3/5 |
| 3 | S73-008 | 1524 | 496 | 5/5 | 15 | S73-905 | 936 | 486 | 3/5 |
| 4 | S73-115 | 2030 | 560 | 1/5 | 16 | S73-906 | 434 | 486 | 3/5 |
| 5 | S73-116 | 2030 | 560 | 1/5 | 17 | S73-910 | 1975 | 999 | 1/5 |
| 6 | S73-117 | 1492 | 559 | 3/5 | 18 | S73-911 | 1975 | 496 | 1/5 |
| 7 | S73-128 | 434 | 541 | 3/5 | 19 | ZS1-1501 | 500 | 120 | 3/5 |
| 8 | S73-309 | 1464 | 560 | 2/5 | 20 | ZS1-1545 | 925 | 120 | 3/5 |
| 9 | S73-310 | 1464 | 560 | 2/5 | 21 | ZS1-1546 | 925 | 120 | 3/5 |
| 10 | S73-311 | 1464 | 560 | 2/5 | 22 | ZS1-1547 | 423 | 120 | 3/5 |
| 11 | S73-313 | 472 | 559 | 3/5 | 23 | ZS1-1548 | 423 | 120 | 3/5 |
| 12 | S73-407 | 1464 | 50 | 2/5 | 24 | dr-969 | 969 | 30 | 3/5 |

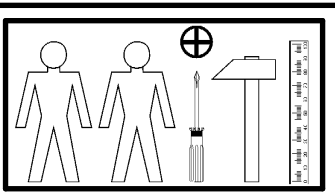

| | | | | | | | | |
|----------------------|----------|---------------|----------------------|------------------------|-----------------------|------------------------|----------------------|--------------------------|
| 6x a44 | 3x a68 | 9x b33 | 12x d1 φ5x17 mm | 18x e2 φ6,3x13 mm | 18x e3 φ6x13 mm | 32x e32 φ5x50 mm | 40x f1 φ8x30 mm | 10x j1 M4x20 mm |
| 6x k1 | 120x l1 | 2x n1 | 2x p1 φ3,5x13 mm | 16x p15 φ2,5x13 mm | 4x p25 φ3,5x16 mm | 18x p51 φ3,5x15 mm | 6x p54 φ3x12 mm | 32x r1 φ1,5x12mm #16 |
| 10x r31 φ21x10mm | 32x r42 | 6x s2 ø16 | 2x t32 475 mm | 4x w26\CL 500 mm | 4x w26\CR 500 mm | 4x w26\DL 500 mm | 4x w26\DR 500 mm | |

1

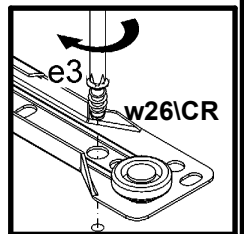
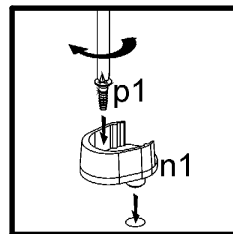
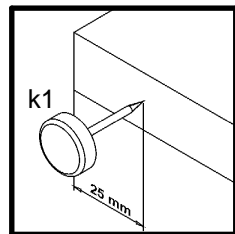
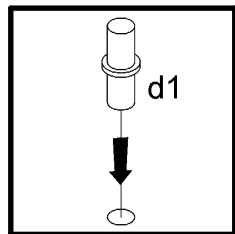
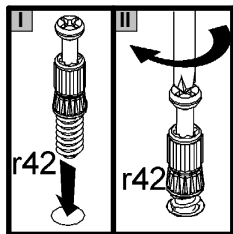
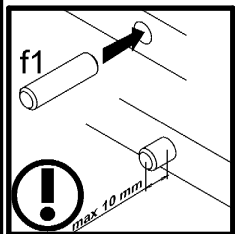
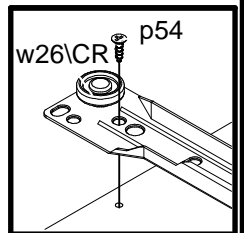
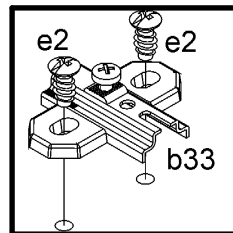
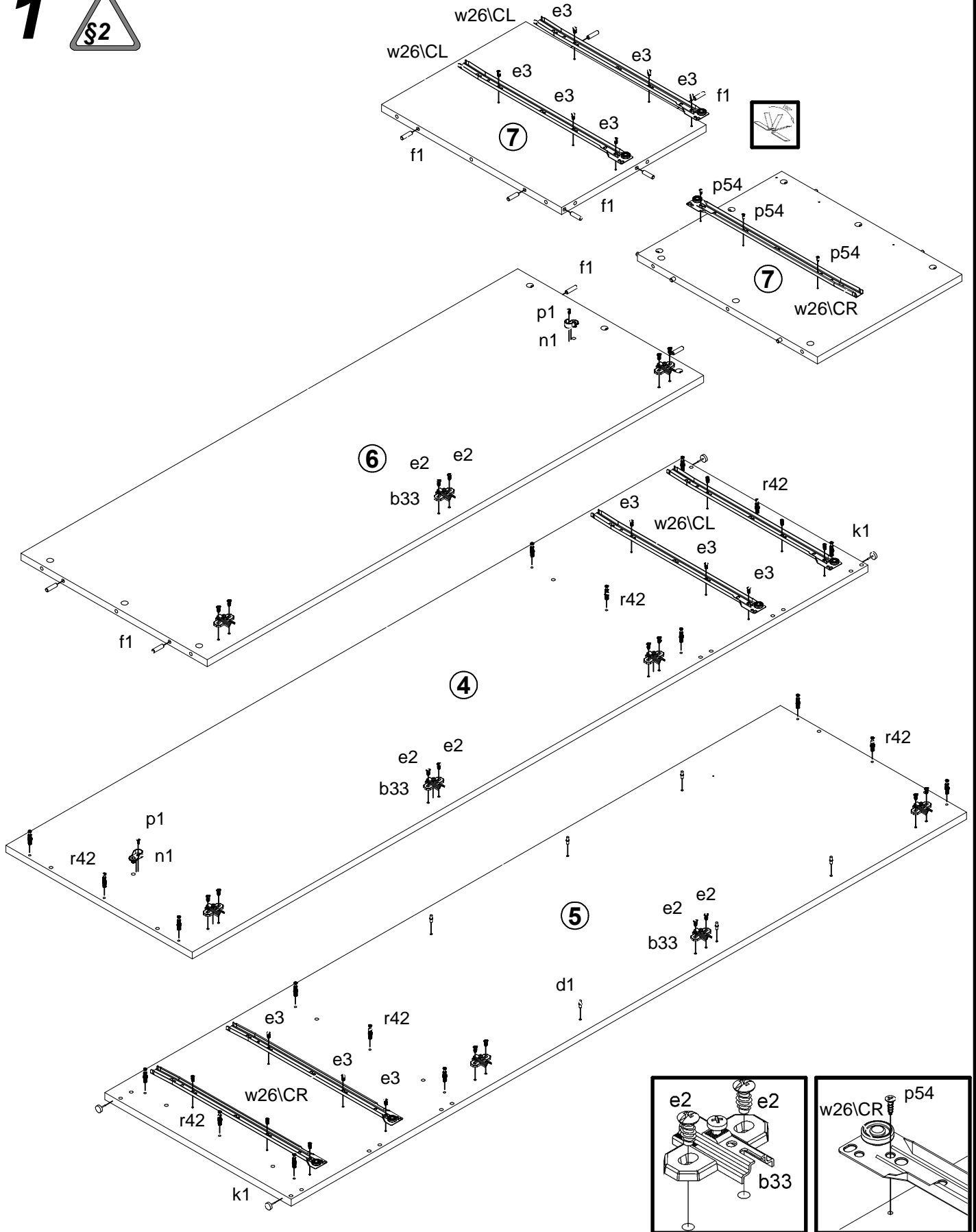

2

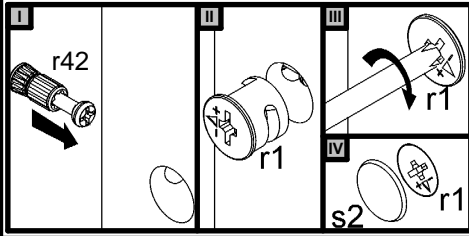
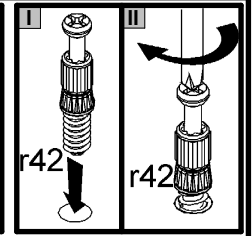
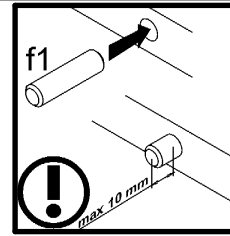
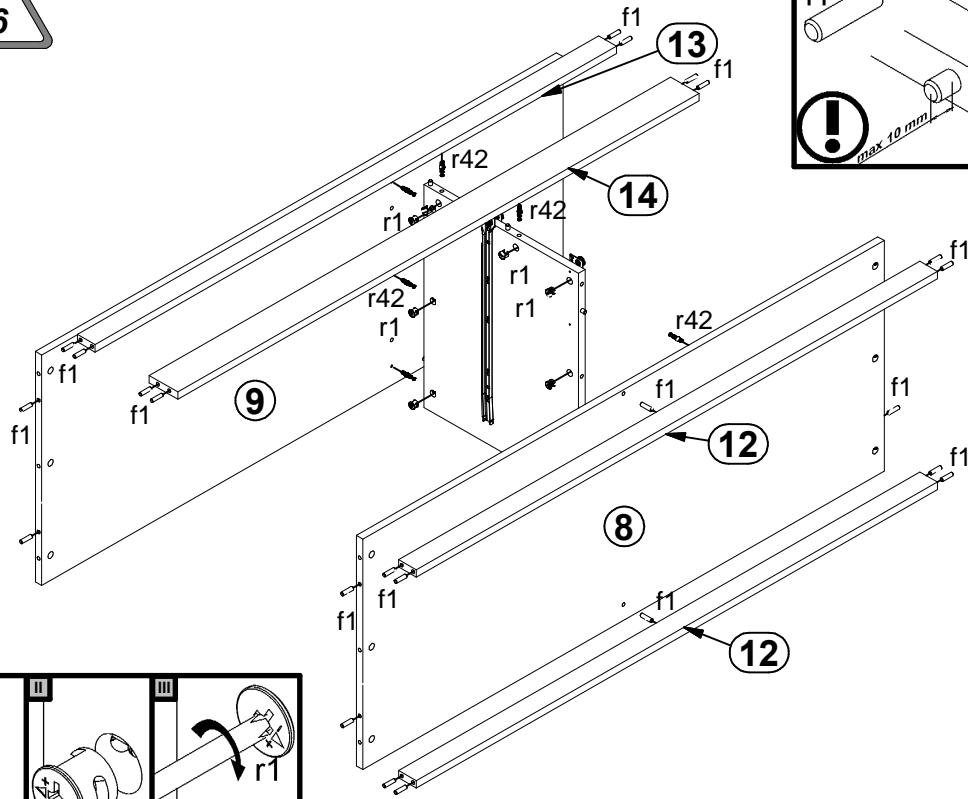

3

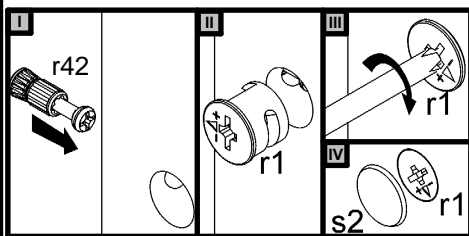
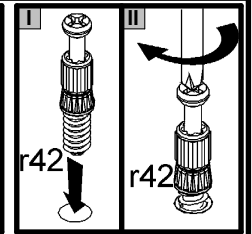
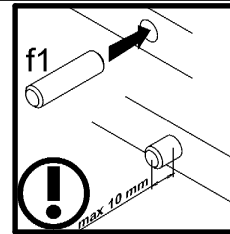
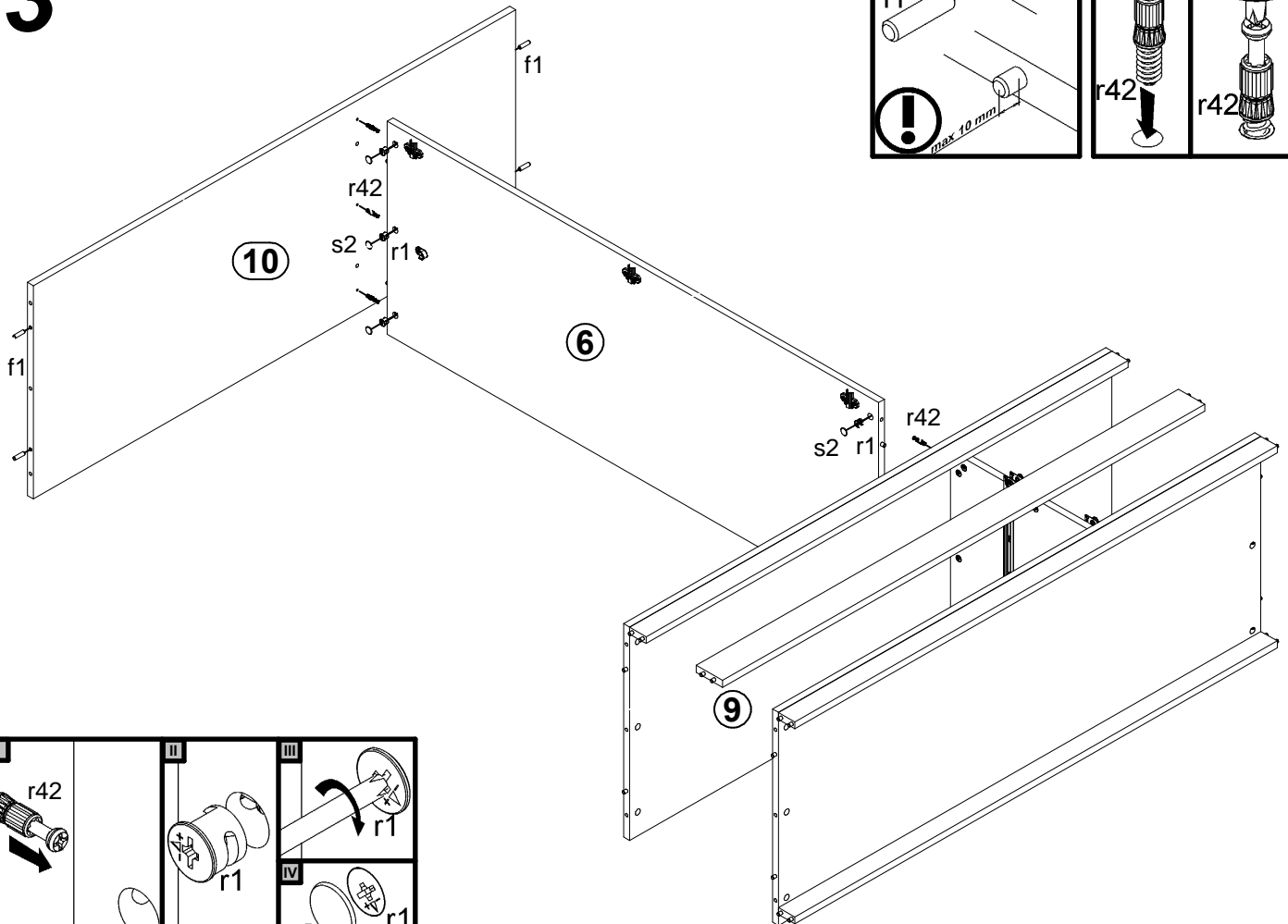

4

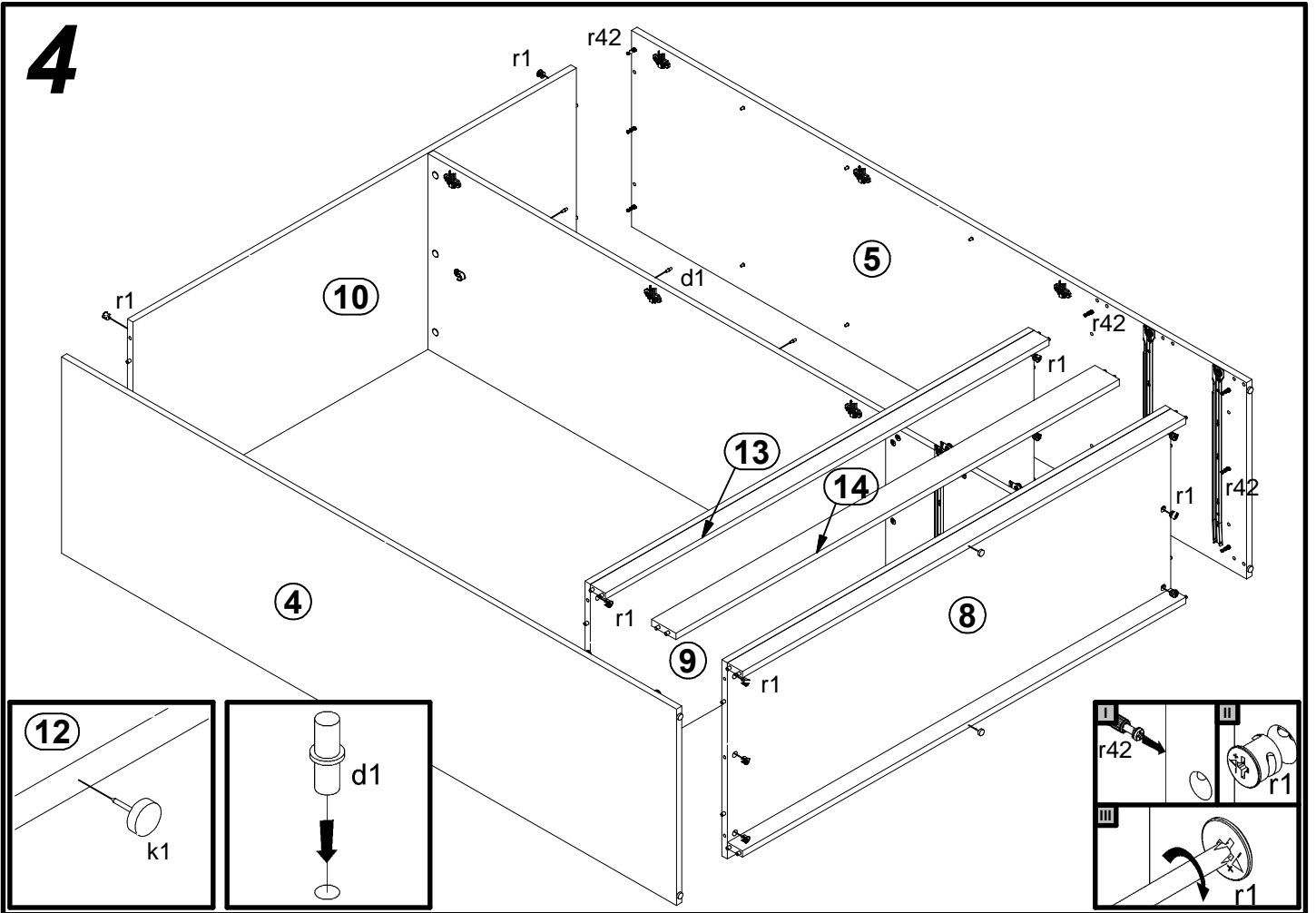

5

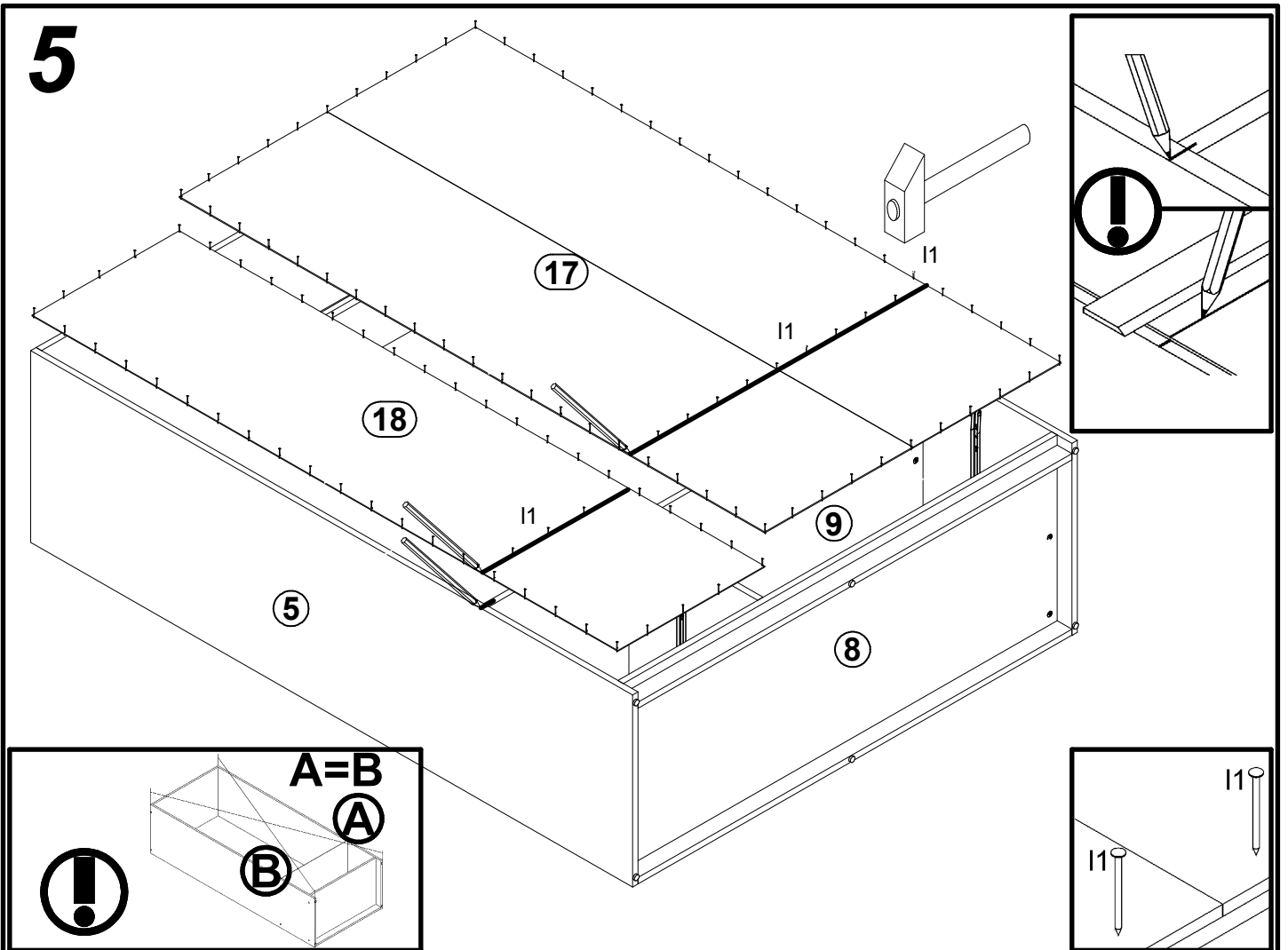

6

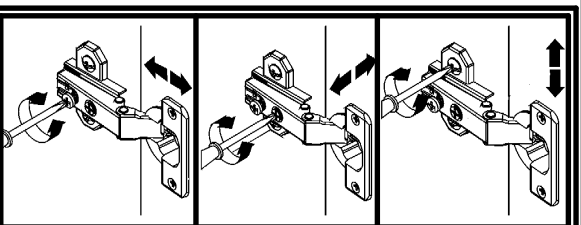
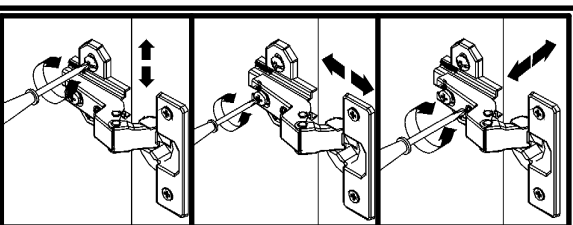
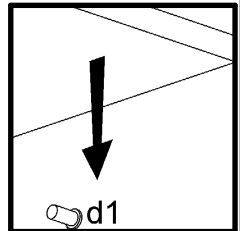
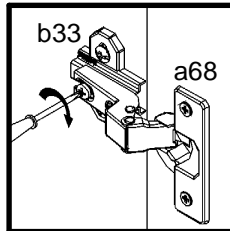
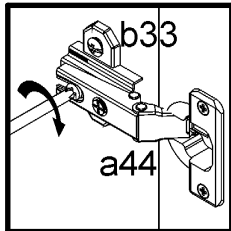
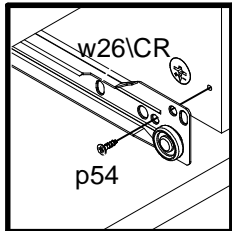
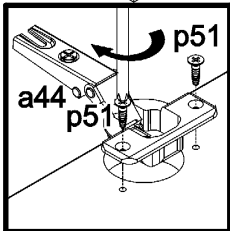
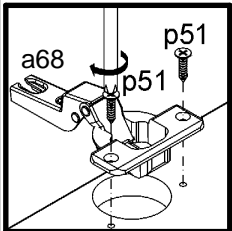
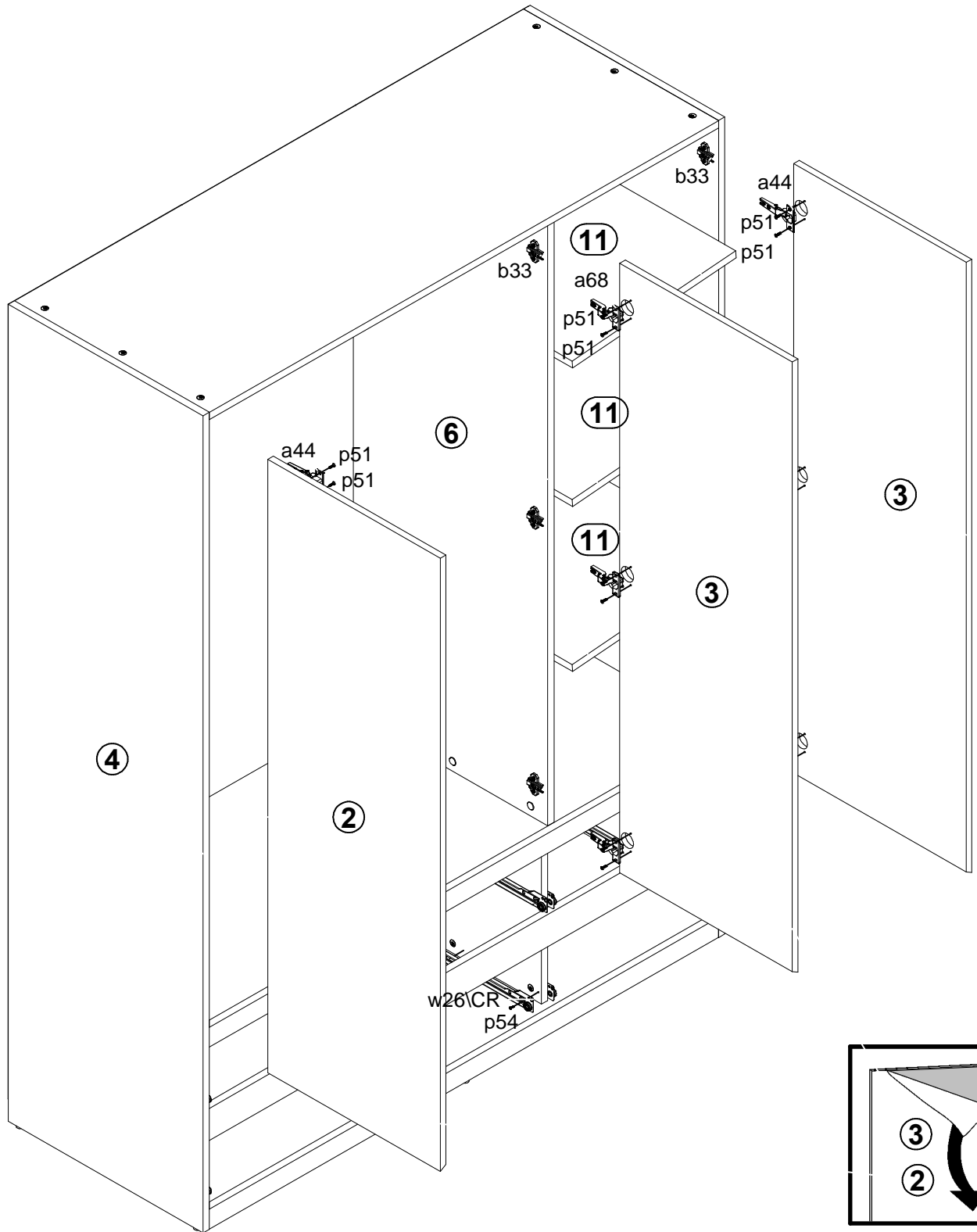

7

