

# THE ASSEMBLY MANUAL,

**Attention:** Before you start the assembly, please get acquainted with the entire assembly manual and stick to the order of assembly presented in this manual.

## TOLEDO RANGE

## TOL4W

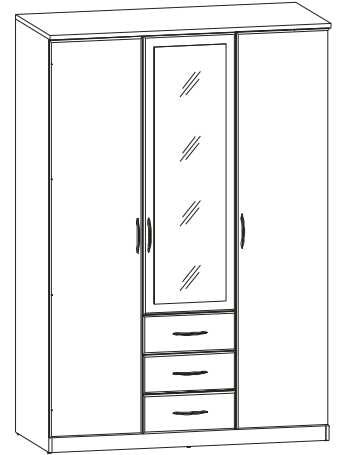
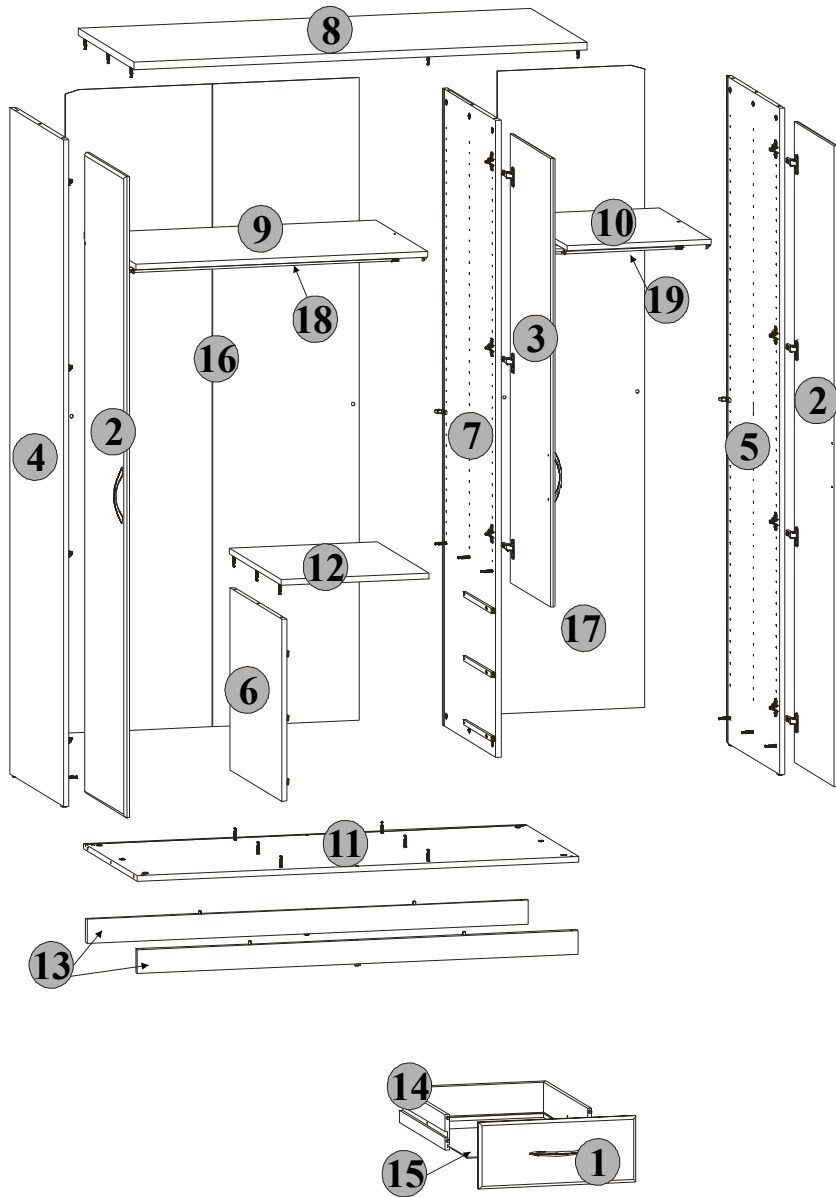



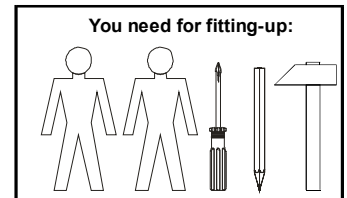



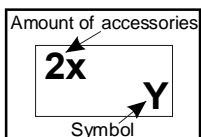



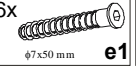
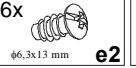

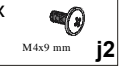

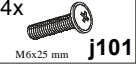
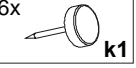
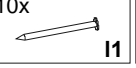
Element symbol	Measurements	Code	Paket
1	446x184	S54-010	4/4
2	1873x446	S54-021	4/4
3	1311x446	S54-022	3/4
4	1948x595	S54-115	1/4
5	1948x595	S54-116	1/4
6	531x575	S54-118	2/4
7	1862x595	S54-125	1/4
8	1351x625	S54-211	2/4
9	870x574	S54-314	2/4
10	431x574	S54-316	2/4
11	1317x595	S54-317	2/4
12	440x575	S54-319	2/4
13	1317x70	S54-411	4/4
14	1376x100	S54-515	2/4
15	402x481	S54-915	2/4
16	1879x878	S54-916	1/4
17	1879x439	S54-917	1/4
18	857x24	dr-857	2/4
19	418x24	dr-418	2/4

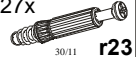

The symbols and the amount of accessories needed for the assembly have been presented below. The accessories can be found in the "Accessories" package.

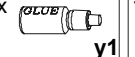
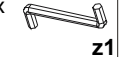
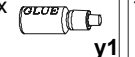
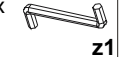

6x  c78	12x  d18	4x  d20	6x  e1 φ7x50 mm	26x  e2 φ6.3x13 mm	11x  a44	11x  b19 D5
12x  j30 M4x22 mm	4x  j101 M6x25 mm	6x  k1	10x  l1	4x  n107	16x  f1 φ8x30 mm	6x  j2 M4x9 mm
27x  r1 φ1.5x12mm #16	27x  r23 30/11	4x  s1	16x  s2 φ16	6x  w4 310 mm	18x  p1 φ3.5x13 mm	30x  p51 φ3.5x15 mm
					1x  y1 GLUB	1x  z1



The first stage of the assembly is equipping the elements with the appropriate accessories according to the drawings below. The Ⓢ symbols denote places to which special attention should be paid during the assembly.

# 1 TOL4W

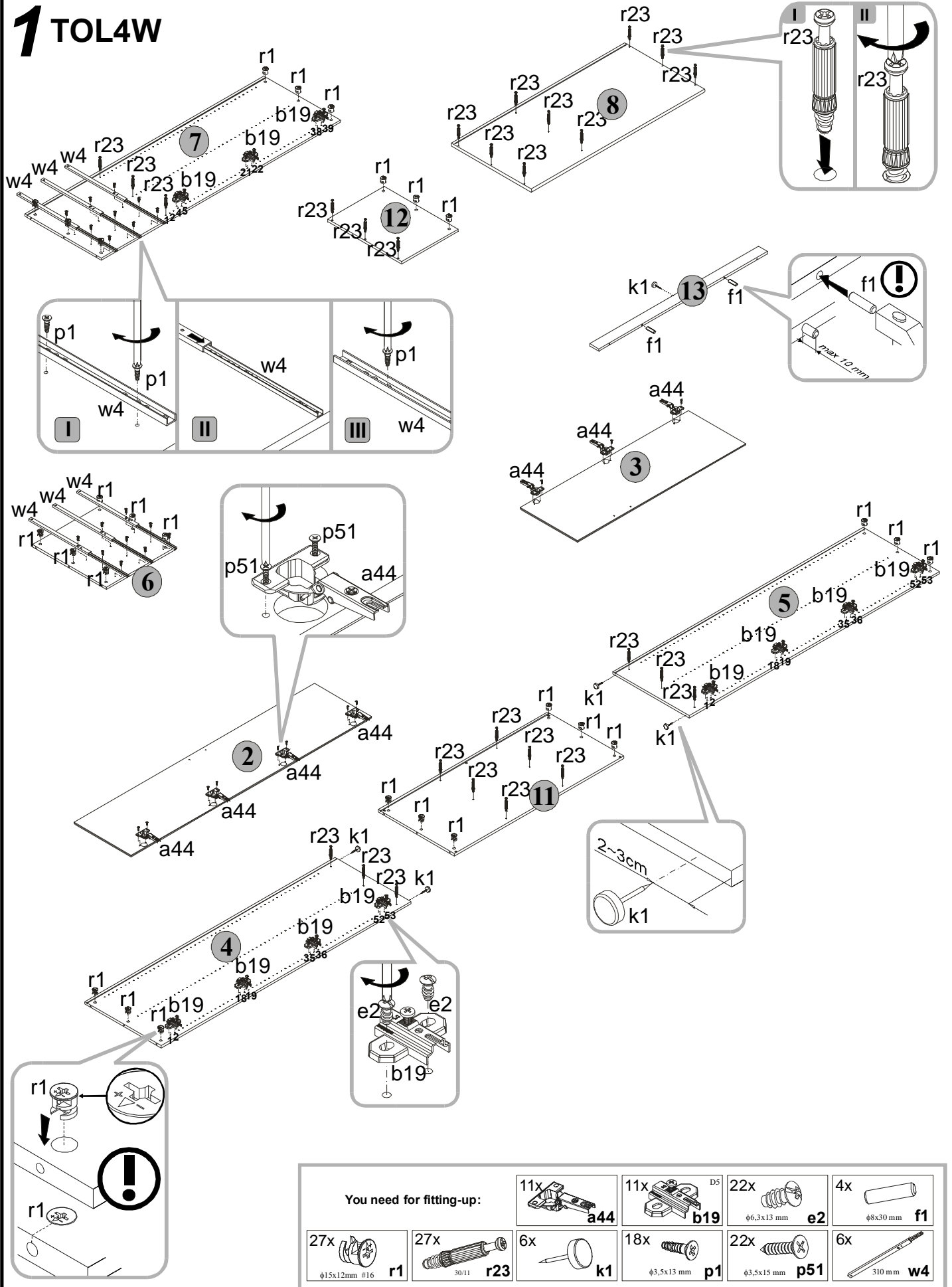

You need for fitting-up:

11x  a44	11x  b19	22x  e2 φ6,3x13 mm	4x  f1 φ8x30 mm
27x  r1 φ15x12mm #16	27x  r23 30/11	6x  k1	18x  p1 φ3,5x13 mm
		22x  p51 φ3,5x15 mm	6x  w4 310 mm



Assemble the unit as shown in the pictures using indicated connectors and/or joints.

## 2 TOL4W

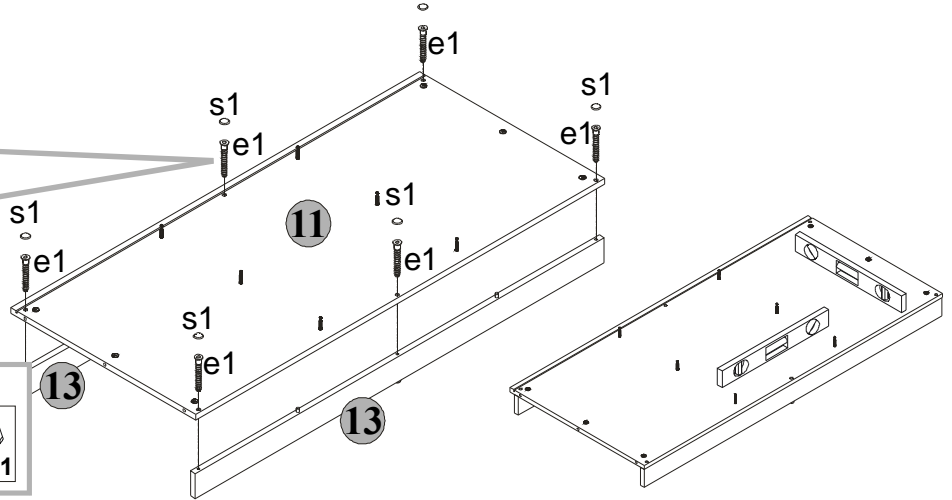
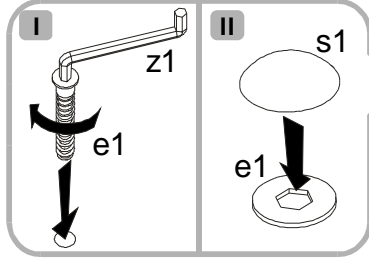

You need for fitting-up:

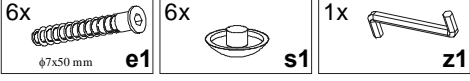

## 3 TOL4W

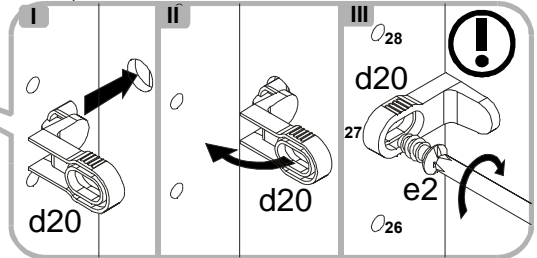
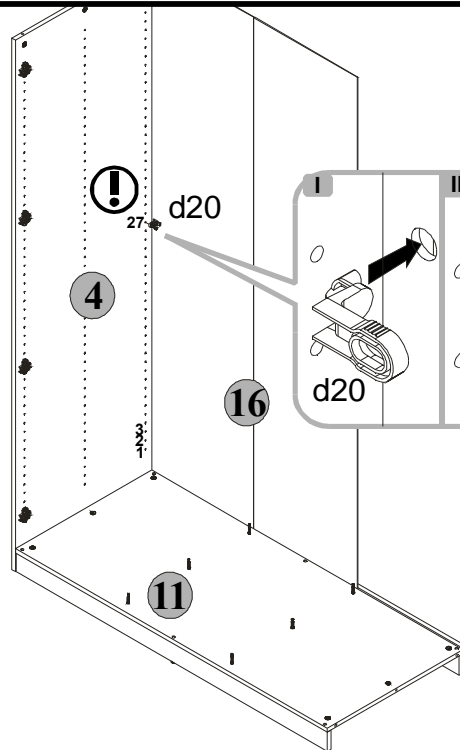
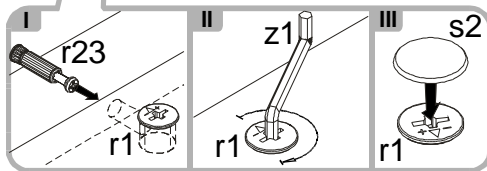
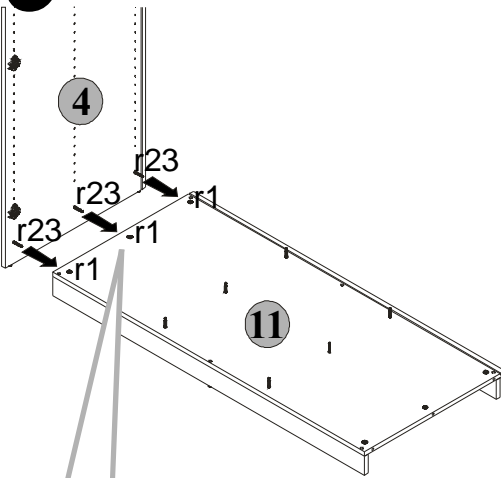

You need for fitting-up:

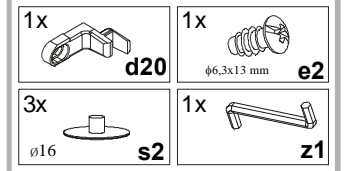

## 4 TOL4W

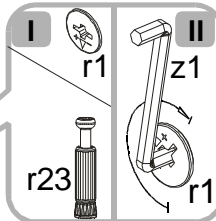
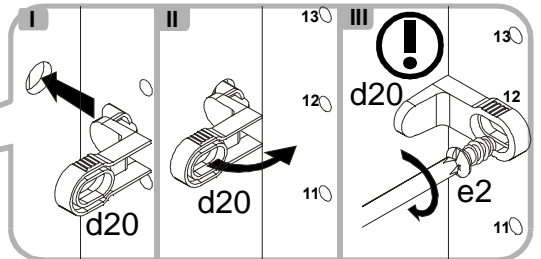
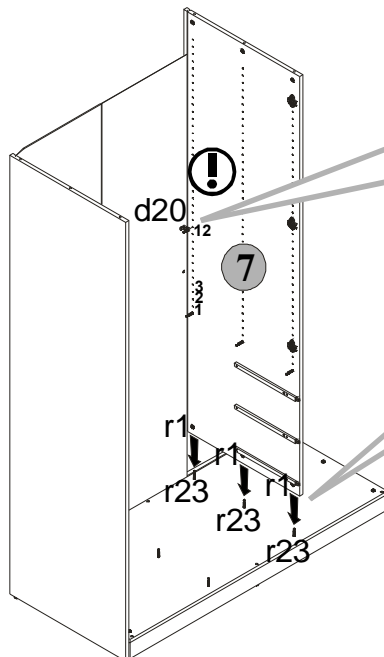

You need for fitting-up:

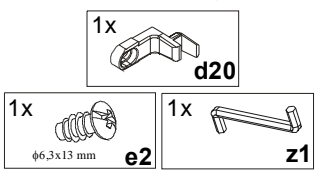

# 5 TOL4W

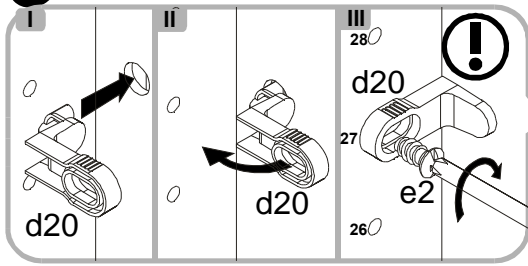

- You need for fitting-up:
- |                 |                        |
|-----------------|------------------------|
| 1x<br>d20       | 1x<br>φ6,3x13 mm<br>e2 |
| 3x<br>ø16<br>s2 | 1x<br>z1               |

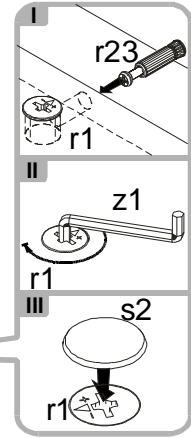
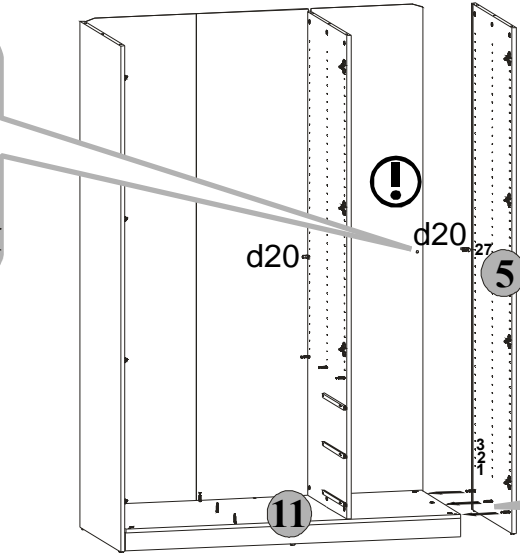

# 6 TOL4W

- You need for fitting-up:
- |                 |          |
|-----------------|----------|
| 9x<br>ø16<br>s2 | 1x<br>z1 |
|-----------------|----------|

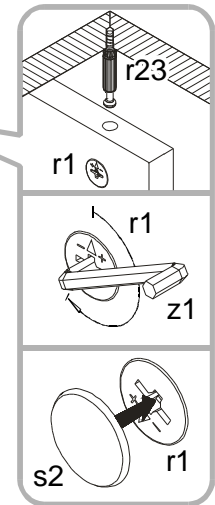
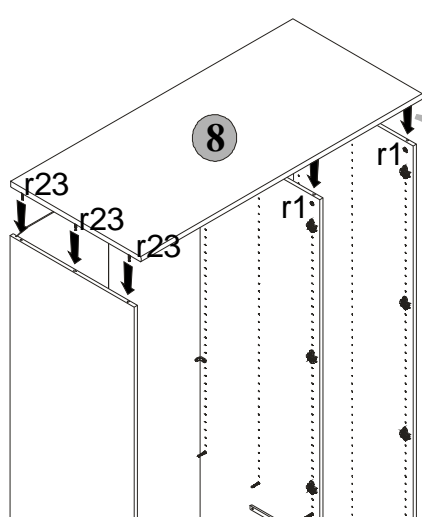

# 7 TOL4W

- You need for fitting-up:
- |          |
|----------|
| 1x<br>z1 |
|----------|

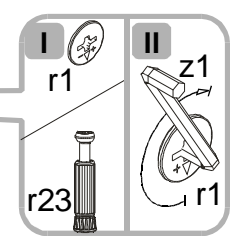
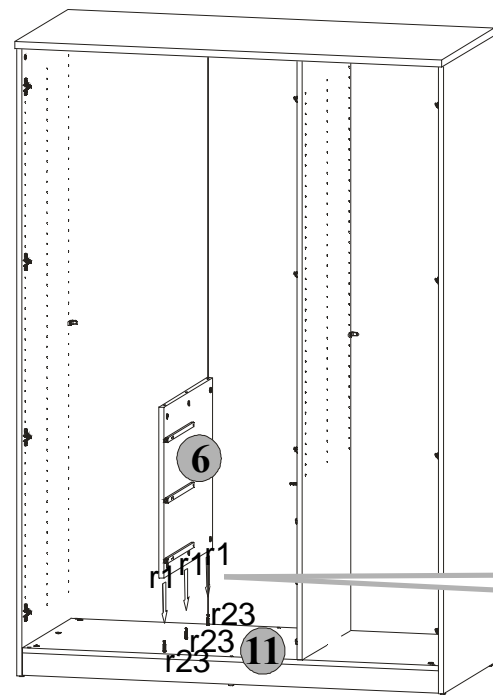

# 8 TOL4W

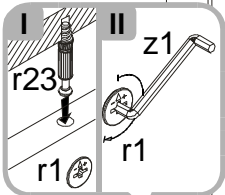

- You need for fitting-up:**
- 10x **r1**
  - 1x **s2**  
ø16
  - 1x **z1**

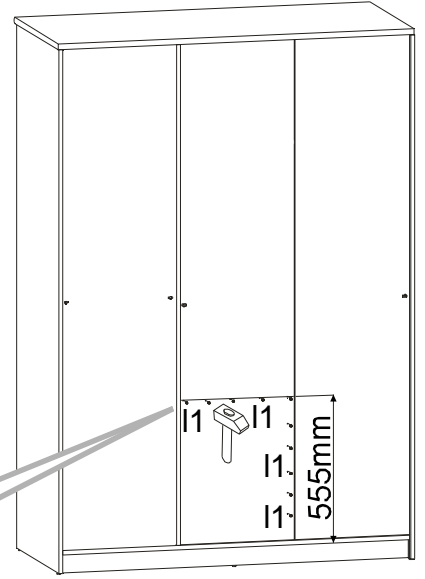
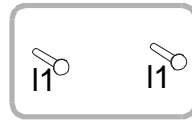
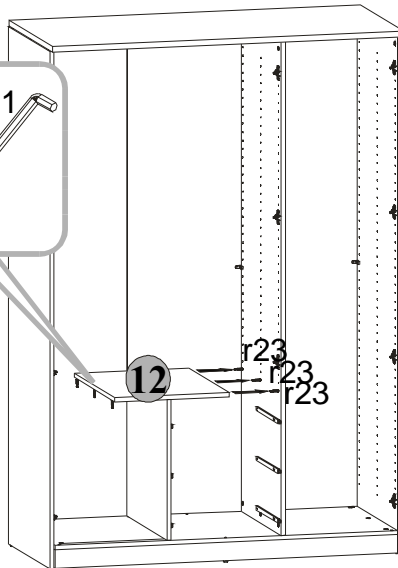

# 9 TOL4W

- You need for fitting-up:**
- 12x **d18**
  - 4x **j101**  
M6x25 mm
  - 4x **n107**
  - 8x **p51**  
ø3,5x15 mm

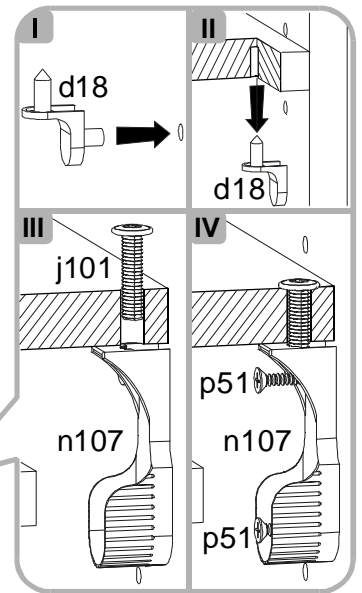
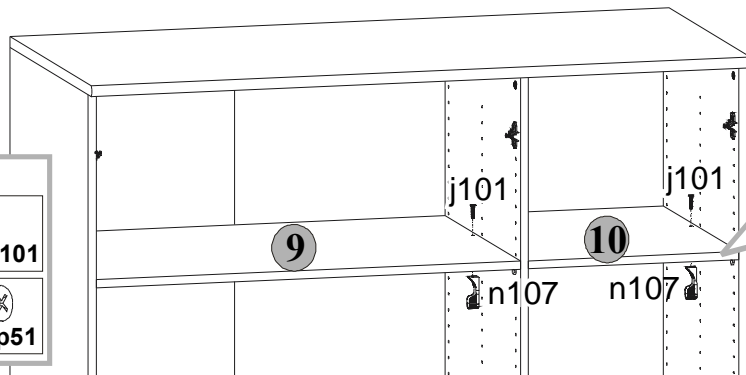

# 10 TOL4W

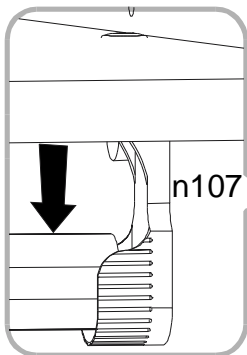

- You need for fitting-up:**
- 3x **c78**
  - 6x **j30**  
M4x22 mm

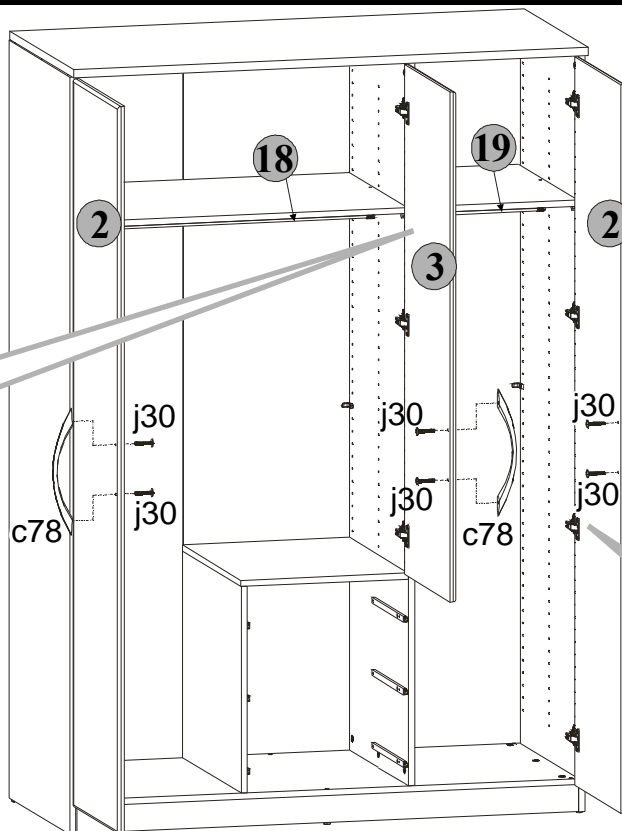

**Adjustment of door**

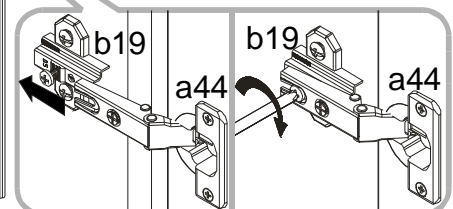
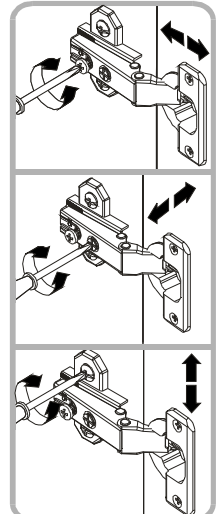

# 11 TOL4W



Attention: The assembly of the drawer should be done very carefully in order to avoid damaging the delicate joints of the drawer band.



Place **y1** glue in the holes in the component shown, mount the component and leave while the glue dries.

**I**

**You need for fitting-up:**

- 12x  $\phi 8 \times 30$  mm **f1**
- 1x **GLUE** **y1**

**II**

**You need for fitting-up:**

- 1x **GLUE** **y1**

**III**

**IV**

**You need for fitting-up:**

- 3x **c78**
- 6x M4x22 mm **j30**
- 1x **GLUE** **y1**

# 12 TOL4W

**You need for fitting-up:**

- 6x M4x9 mm **j2**