

THE ASSEMBLY MANUAL

Attention: Before you start the assembly, please get acquainted with the entire assembly manual and stick to the order of assembly presented in this manual.

TOLB46

Symbol elementu Značka dílu Element symbol Jel elemek Symbol elementu	Wymiary Rozměry Measurements Nagyság Rozmery	Kód Kód Code Kód Kód	Paczka Krabica Paket Csomagban Balik
1	1462x370	LC1-132	1/3
2	1957x180	LC1-130	2/3
3	1957x180	LC1-134	2/3
4	1452x180	LC1-131	2/3
5	1795x25	LC1-417	2/3
6	1910x70	LC1-416	2/3
7	1463x501	LC1-418	1/3
8	1751x1386	LC1-419	1/1
9	665x37	n64	2/3
10	262x70	LC1-420	2/3

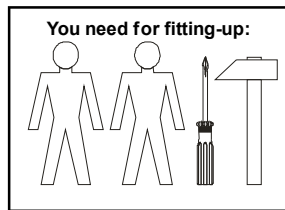
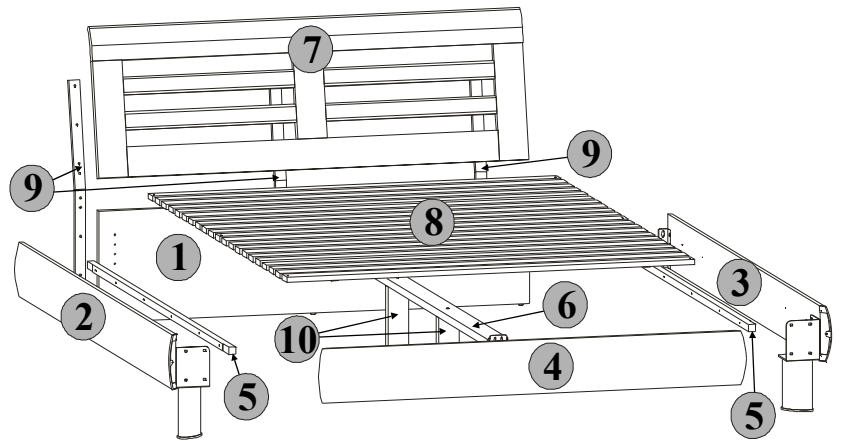

The symbols and the amount of accessories needed for the assembly have been presented below. The accessories can be found in the "Accessories" package.

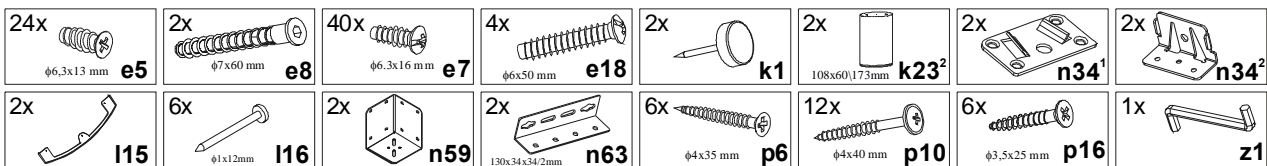
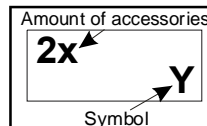

General instructions for furniture assembly

Attention

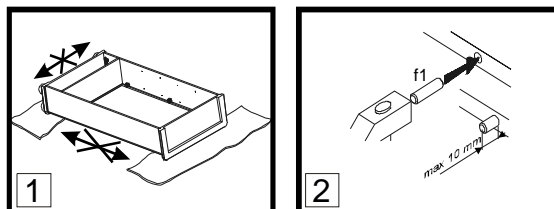

Attention:

1. During the assembly, the elements should be put on a soft and clean surface, e.g. a towel or a blanket. Do not assemble the piece on a carpet or floor covering, etc.
2. Drive *f1* pegs into the holes (8 mm in diameter) located along the edges of each element (leave the holes for the eccentric connector pivot free). **Attention:** In case a peg in one of the holes protrudes more than 10 mm, it should be hammered down, exchanged or shortened because it may cause damage to the side of the piece of furniture during its assembly.

INFORMATION!

Dear client, in case of complaining, please use the code number given in the assembly instruction. Any comments and complaints should be reported at the furniture purchase outlet. **Note!** Do not use any parts showing any faults or marks of damage.



The first stage of the assembly is equipping the elements with the appropriate accessories according to the drawings below. The ⊕ symbols denote places to which special attention should be paid during the assembly.

1 TOLB46

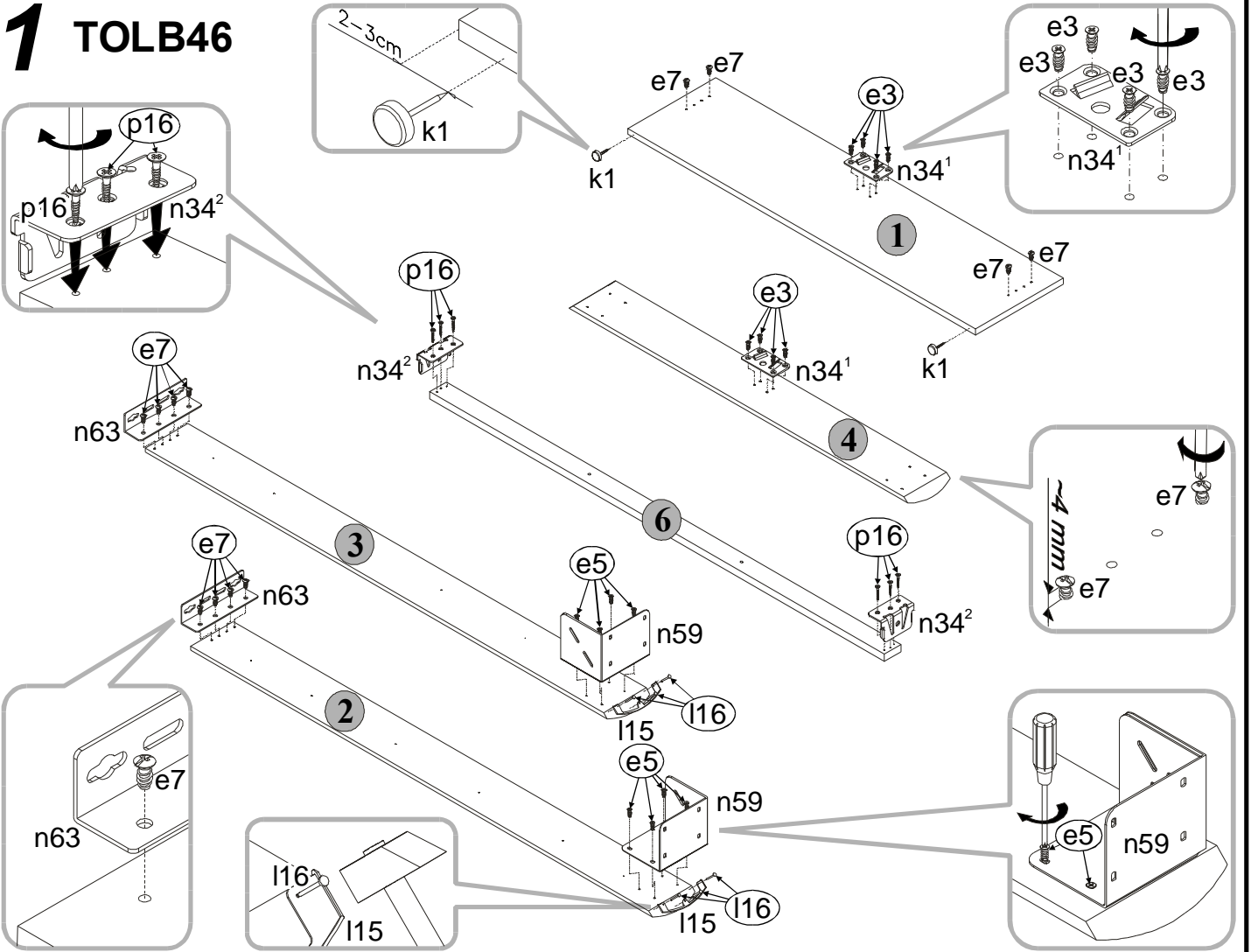

You need for fitting-up:

16x ⊕ φ6.3x13 mm e5	2x ⊕ φ7x60 mm e8	40x ⊕ φ6.3x16 mm e7	4x ⊕ φ6x50 mm e18	2x ⊕ k1	2x n34 ¹
2x n34 ²	2x l15	6x ⊕ φ1x12mm l16	2x n59	2x n63	6x ⊕ φ4x35 mm p6
					6x ⊕ φ3.5x25 mm p16



Assemble the unit as shown in the pictures using indicated connectors and/or joints.

2 TOLB46

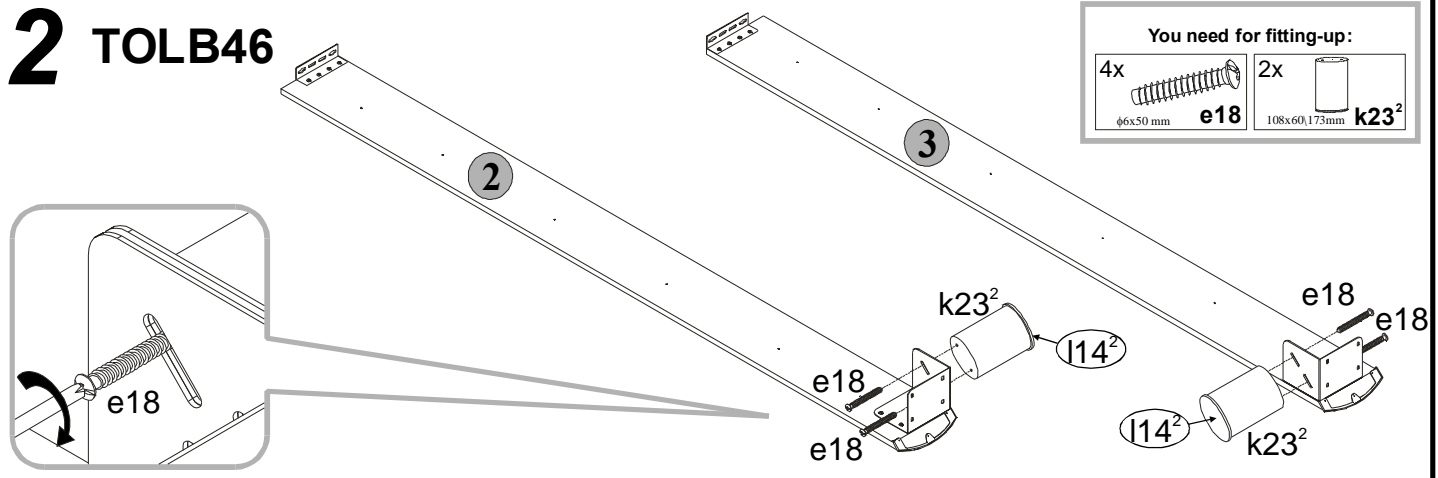

You need for fitting-up:

4x ⊕ φ6x50 mm e18	2x k23 ²
----------------------------	------------------------

3 TOLB46

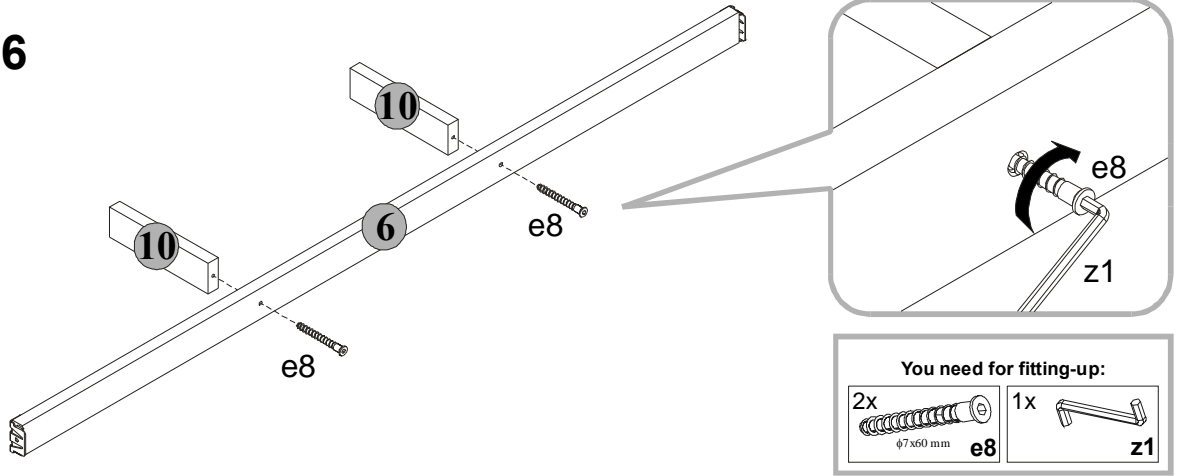

4 TOLB46

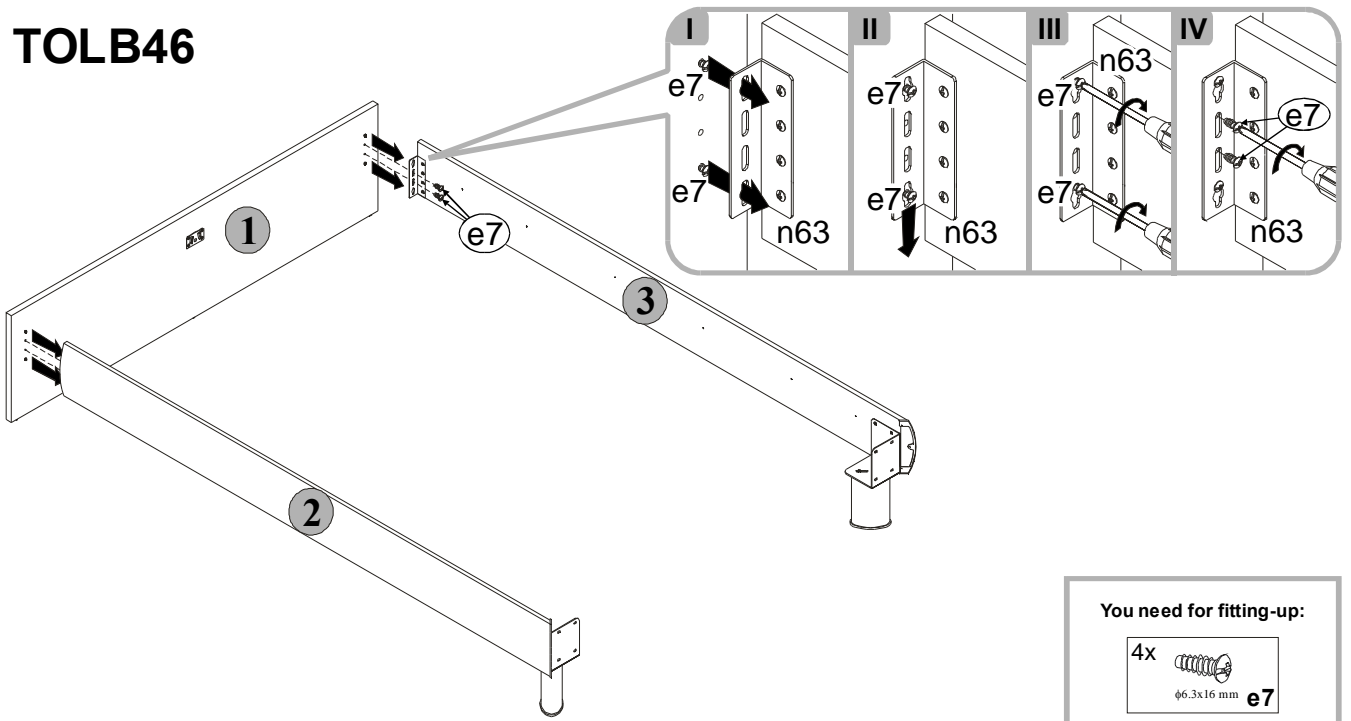

5 TOLB46

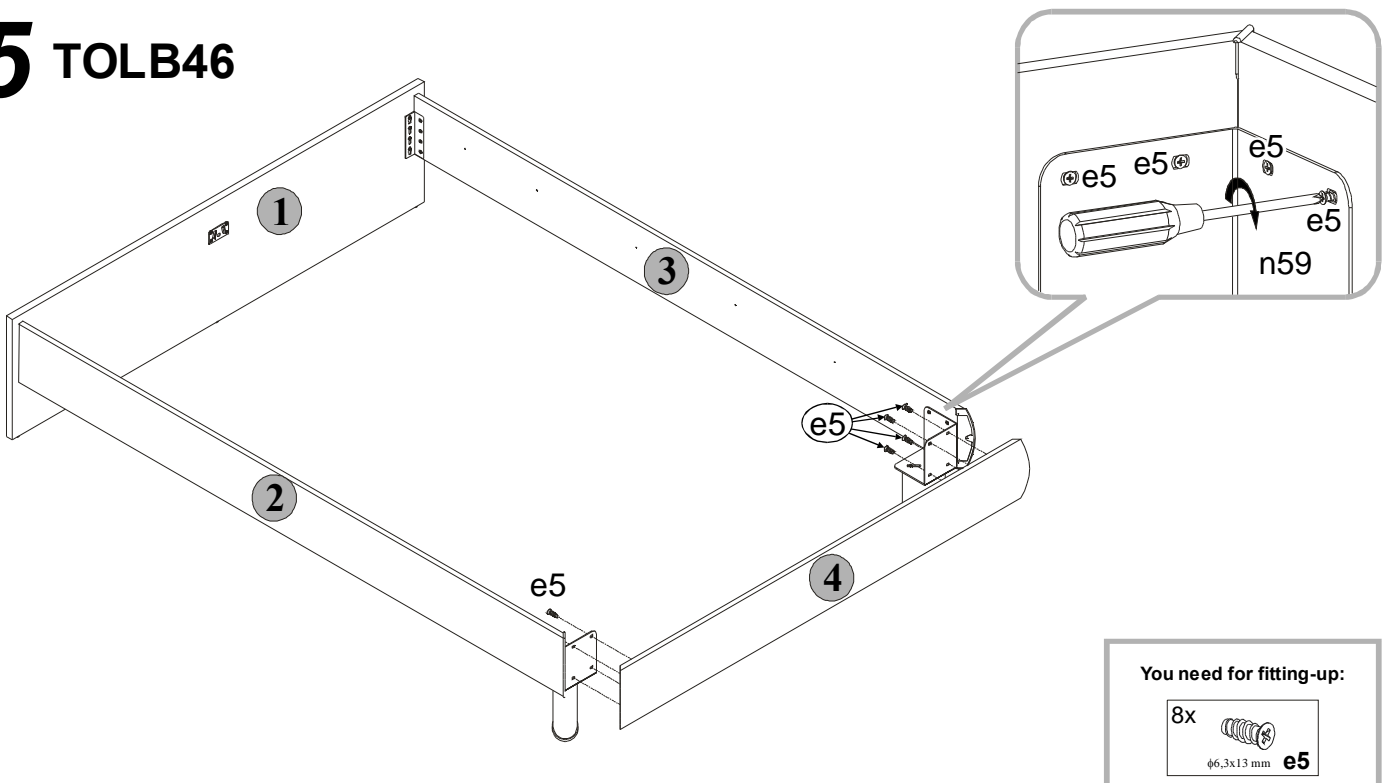

6 TOLB46

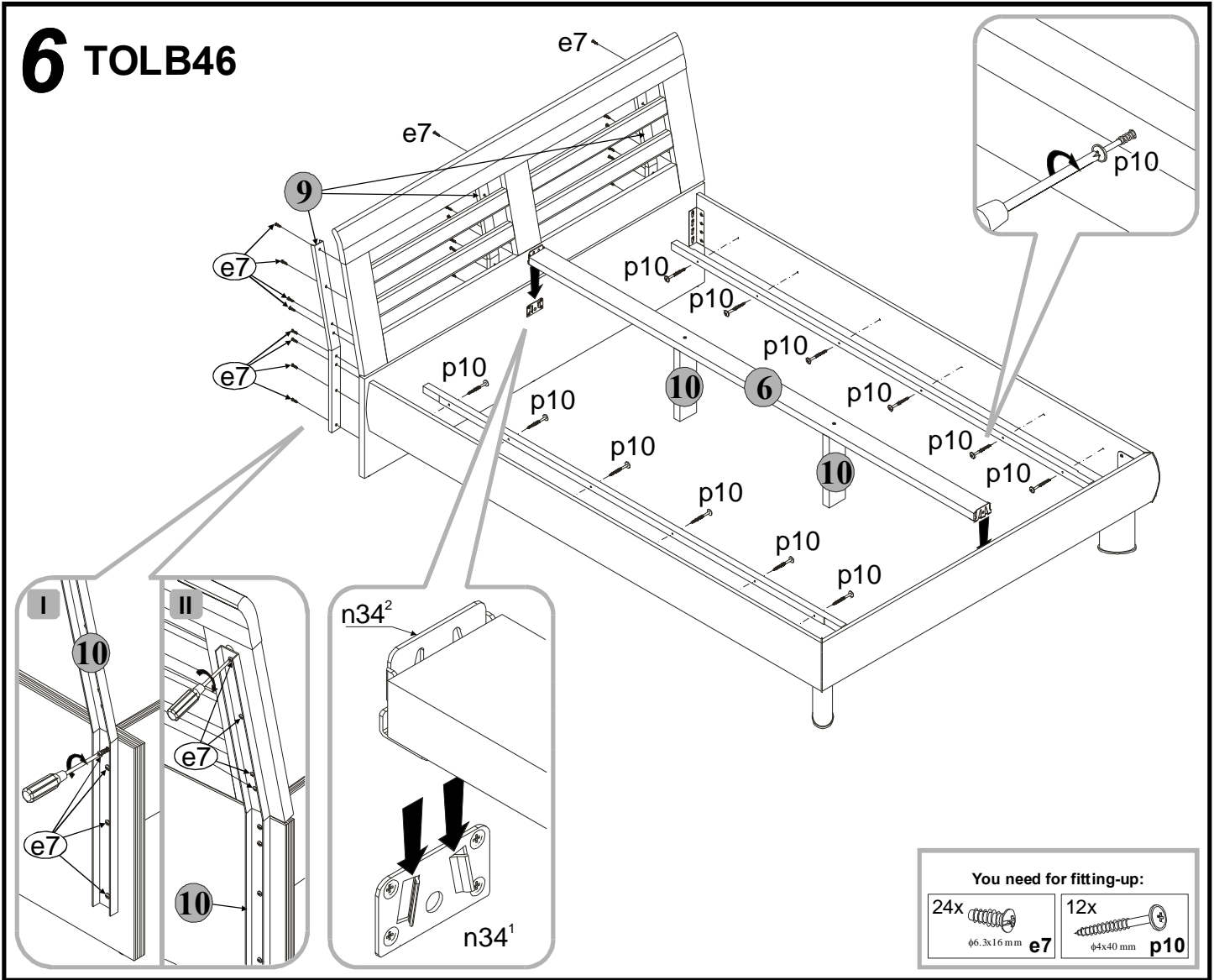

7 TOLB46

