

THE ASSEMBLY MANUAL

Attention: Before you start the assembly, please get acquainted with the entire assembly manual and stick to the order of assembly presented in this manual.

TOLEDO RANGE

Chest 10s

Element symbol	Measurements	Code	Paket
1	716x152	S44-005	2/2
2	716x152	S44-006	2/2
3	846x417	S44-103	1/2
4	846x417	S44-104	1/2
5	846x397	S44-110	1/2
6	1440x447	S44-204	2/2
7	1406x70	S44-405	2/2
8	1406x70	S44-413	2/2
9	320x100	S44-517	1/2
10	320x100	S44-518	1/2
11	664x100	S44-520	1/2
12	852x707	S44-910	1/2
13	852x707	S44-921	1/2
14	674x320	S44-911	2/2

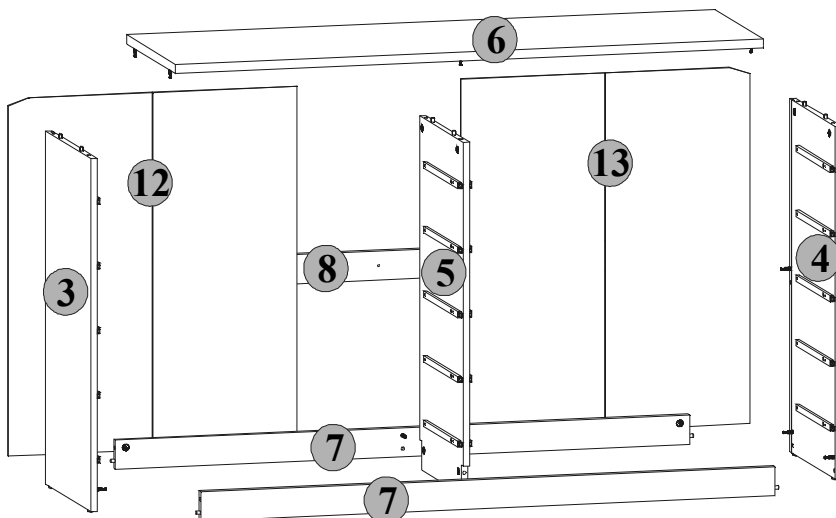

You need for fitting-up:

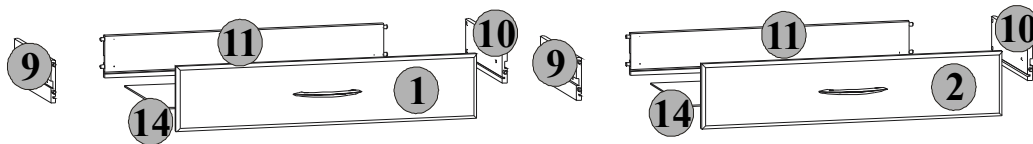
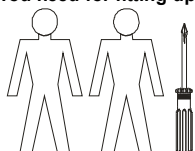

The symbols and the amount of accessories needed for the assembly have been presented below. The accessories can be found in the "Accessories" package.

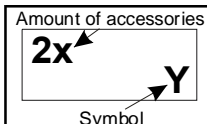

10x c78	94x f1 ø8x30 mm	20x j2 M4x9 mm	20x j30 M4x22 mm	6x k1	12x l2
6x n108 20x13x3,5/1 mm	60x p1 ø3,5x13 mm	10x p25 ø3,5x16 mm	10x p35 ø3,5x10 mm	12x p38 ø3,5x16 mm	6x p55 ø2,9x16 mm
14x r1 ø15x12mm #16	14x r16	3x s2 ø16	10x t4 320 mm	20x w4 310 mm	1x z1
					1x y1

<input type="checkbox"/> TÁŠMA ZABEZPEČAČA
<input type="checkbox"/> БЕЗОПАСИТЕЛЬНАЯ ЛЕНТА
<input type="checkbox"/> ZAJIŠTŮJICÍ PÁSKA
<input type="checkbox"/> DAS SICHERU
<input type="checkbox"/> BANDE DE SURETE
<input type="checkbox"/> THE ANTI-TOPPLE DEVICE
<input type="checkbox"/> ZASTIŇNÁ TRAKA
<input type="checkbox"/> BIZTOSÍTÓ SZALAG
<input type="checkbox"/> BANDA DE SIGURANTA
<input type="checkbox"/> ПРЕДОХРАНИТЕЛЬНАЯ ЛЕНТА
<input type="checkbox"/> OCHRANNÁ PÁSKA

General instructions for furniture assembly

Attention

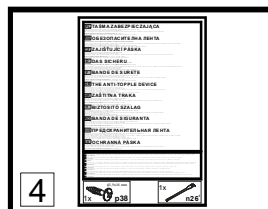
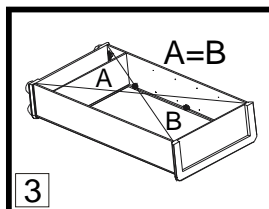
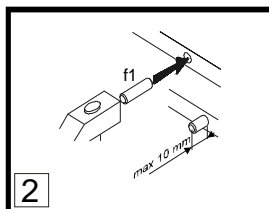
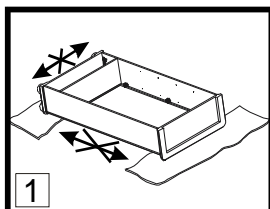

Attention:

- During the assembly, the elements should be put on a soft and clean surface, e.g. a towel or a blanket. Do not assemble the piece on a carpet or floor covering, etc.
- Drive *f1* pegs into the holes (8 mm in diameter) located along the edges of each element (leave the holes for the eccentric connector pivot free). **Attention:** In case a peg in one of the holes protrudes more than 10 mm, it should be hammered down, exchanged or shortened because it may cause damage to the side of the piece of furniture during its assembly.
- Before nailing a fiberboard, make sure that the diagonals are equal.
- The anti-topple device. When assembling the furniture follow the instructions in the manual. Improper fixing of the piece of furniture may cause it to topple when it is used.

INFORMATION!

Dear client, in case of complaining, please use the code number given in the assembly instruction. Any comments and complaints should be reported at the furniture purchase outlet. **Note!** Do not use any parts showing any faults or marks of damage.



The first stage of the assembly is equipping the elements with the appropriate accessories according to the drawings below. The ⊕ symbols denote places to which special attention should be paid during the assembly.

1 Chest 10s

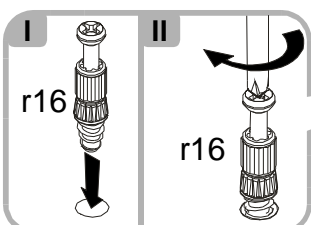
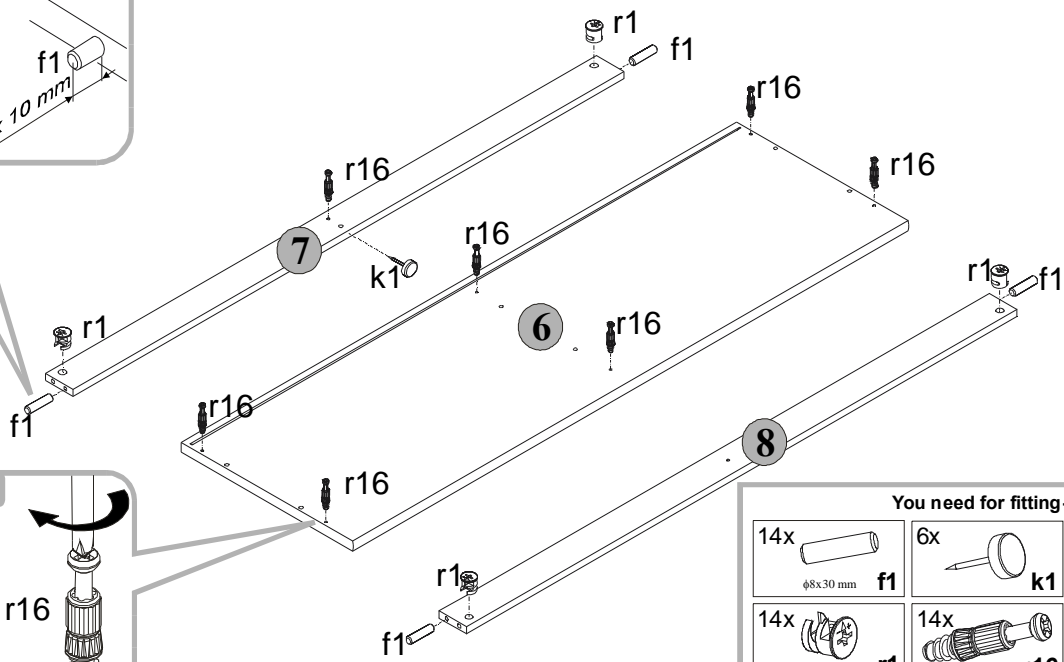
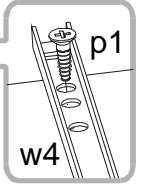
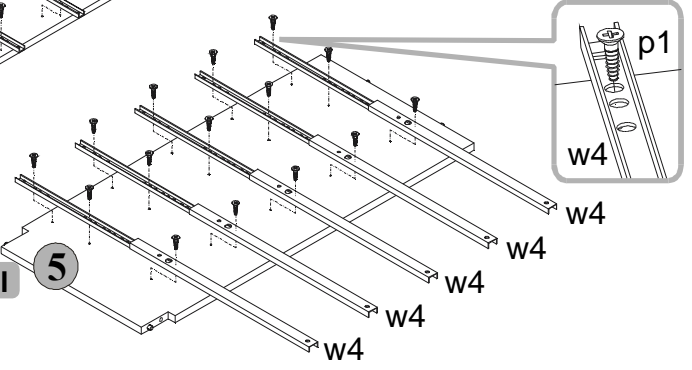
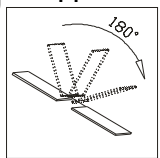
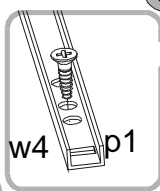
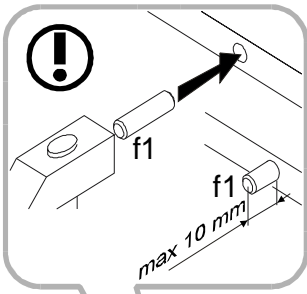
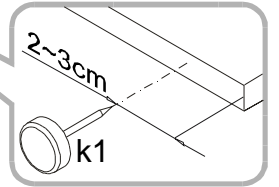
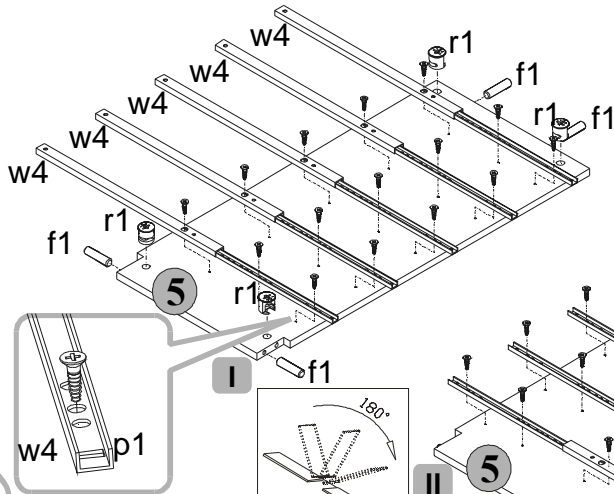
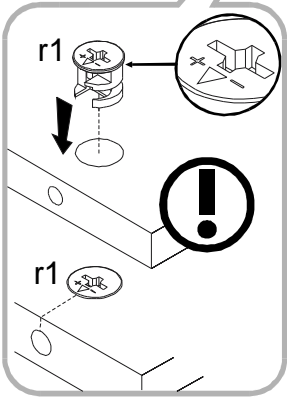
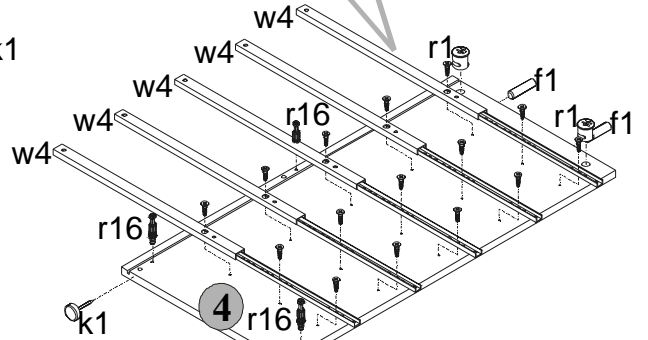
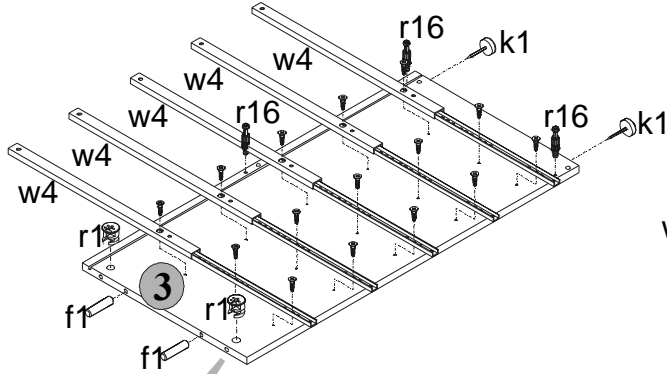
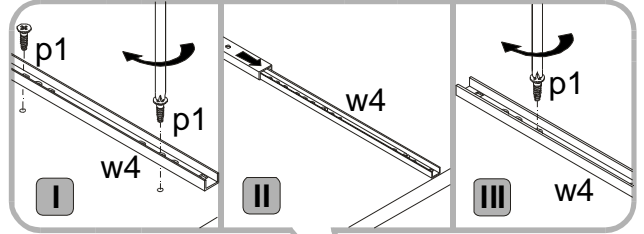

You need for fitting-up:

14x φ8x30 mm f1	6x k1	60x φ3,5x13 mm p1
14x φ15x12mm #16 r1	14x r16	20x 310 mm w4

6 Chest 10s

I

You need for fitting-up:

- 80x $\phi 8 \times 30$ mm f1
- 1x GLUE y1

II

You need for fitting-up:

- 1x GLUE y1

III

You need for fitting-up:

- 10x c78
- 20x M4x22 mm j30
- 1x GLUE y1

IV

You need for fitting-up:

- 10x $\phi 3.5 \times 16$ mm p25
- 10x $\phi 3.5 \times 10$ mm p35
- 10x 320 mm t4

7 Chest 10s

You need for fitting-up:

- 20x M4x9 mm j2