

THE ASSEMBLY MANUAL,

Attention: Before you start the assembly, please get acquainted with the entire assembly manual and stick to the order of assembly presented in this manual.

TOLEDO RANGE Wardrobe 2d3s

Element symbol	Measurements	Code	Paket
1	1873x446	S44-021	4/4
2	1311x446	S44-022	3/4
3	446x184	S44-023	4/4
4	1948x595	S44-115	1/4
5	531x575	S44-118	2/4
6	1948x595	S44-123	1/4
7	900x625	S44-210	2/4
8	866x575	S44-310	2/4
9	866x574	S44-311	2/4
10	435x575	S44-312	2/4
11	866x70	S44-410	2/4
12	1371x100	S44-524	1/4
13	397x481	S44-912	1/4
14	1891x883	S44-923	1/4
15	853x24	dr-853	2/4

You need for fitting-up:

§1 The symbols and the amount of accessories needed for the assembly have been presented below. The accessories can be found in the "Accessories" package.

5x c78	6x d18	14x e2	30x f1	6x j2	10x j30	2x j101
4x k1	18x l2	2x n107	4x n108	18x p1	9x p38	4x p55
18x p51	25x r1	25x r16	7x s2	6x w4	1x y1	1x z1

Amount of accessories: **2x** Symbol: **Y**

7x a44	7x b19	D5
<input type="checkbox"/> TASMA ZABEZPEČIČKA <input type="checkbox"/> ОБЕСОПАСИТЕЛНА ЛЕНТА <input type="checkbox"/> ЗАШТИТНА ПАСКА <input type="checkbox"/> DAS SICHERUNG <input type="checkbox"/> BANDE DE SÛRETÈ <input type="checkbox"/> THE ANTI-TOPPLE DEVICE <input type="checkbox"/> ZAŠTITNA TRAKA <input type="checkbox"/> BIZTOSÍTÓ SZALAG <input type="checkbox"/> BANDA DE SIGURANȚA <input type="checkbox"/> ПРЕДОХРАНИТЕЛЬНАЯ ЛЕНТА <input type="checkbox"/> OCHRANĀ PĀSKA		
1x p38	1x n26	

General instructions for furniture assembly

Attention

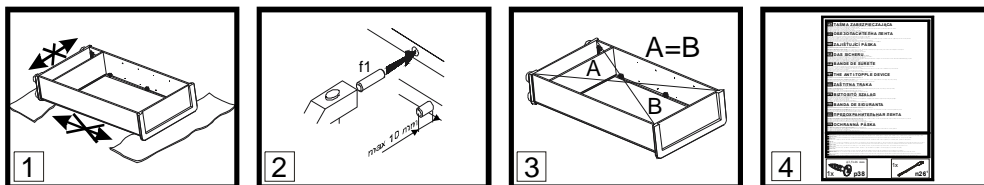

Attention:

- During the assembly, the elements should be put on a soft and clean surface, e.g. a towel or a blanket. Do not assemble the piece on a carpet or floor covering, etc.
- Drive *f1* pegs into the holes (8 mm in diameter) located along the edges of each element (leave the holes for the eccentric connector pivot free). **Attention:** In case a peg in one of the holes protrudes more than 10 mm, it should be hammered down, exchanged or shortened because it may cause damage to the side of the piece of furniture during its assembly.
- Before nailing a fiberboard, make sure that the diagonals are equal.
- The anti-topple device. When assembling the furniture follow the instructions in the manual. Improper fixing of the piece of furniture may cause it to topple when it is used.

INFORMATION!

Dear client, in case of complaining, please use the code number given in the assembly instruction. Any comments and complaints should be reported at the furniture purchase outlet. **Note!** Do not use any parts showing any faults or marks of damage.



The first stage of the assembly is equipping the elements with the appropriate accessories according to the drawings below. The Ⓞ symbols denote places to which special attention should be paid during the assembly.

1 Wardrobe 2d3s

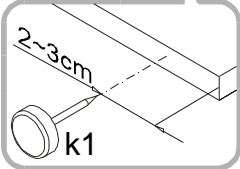
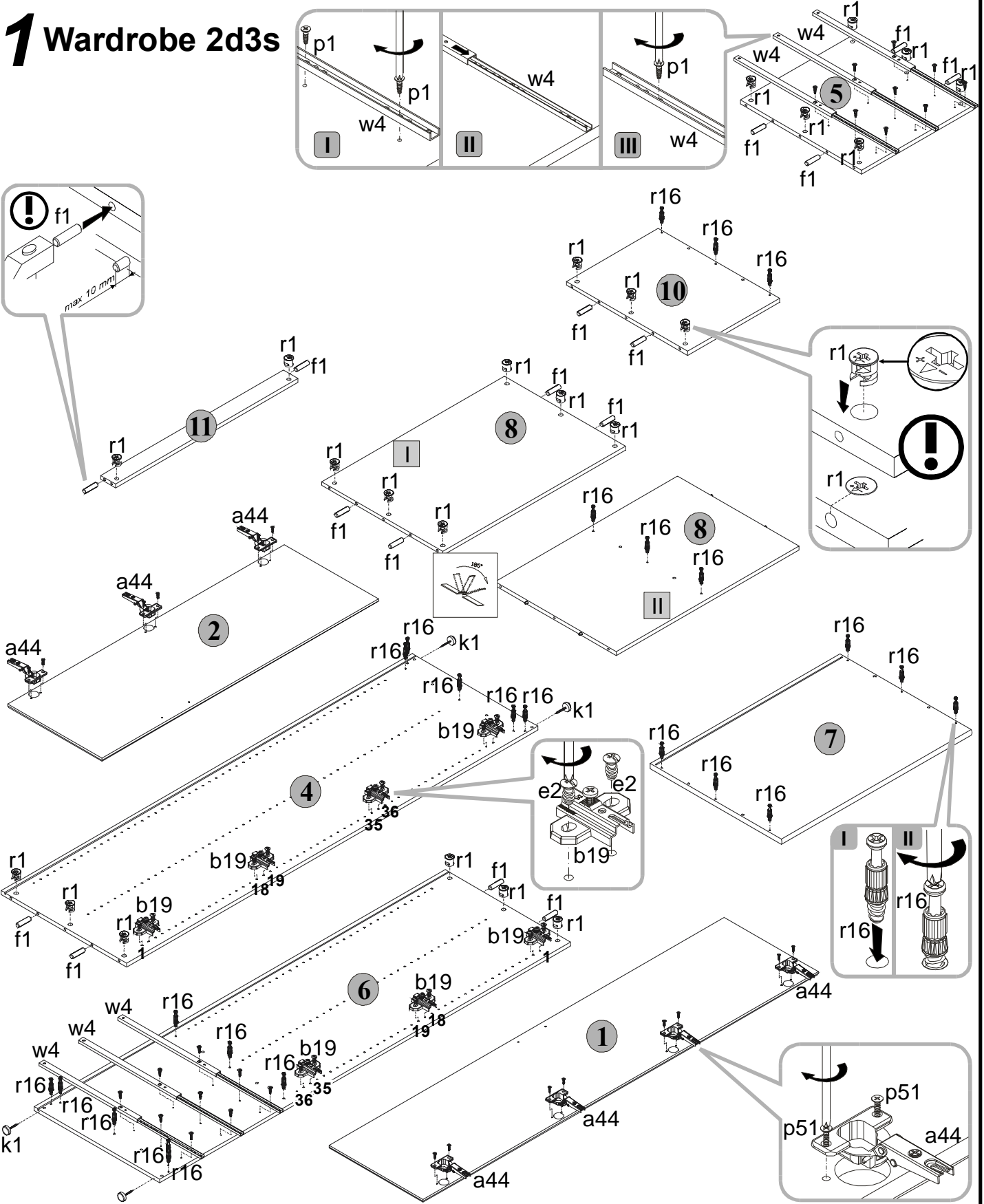

You need for fitting-up:

25x r1 φ15x12mm #16	25x r16	4x k1	7x a44	7x b19	14x e2 φ6,3x13 mm	18x f1 φ8x30 mm	18x r16	14x p1 φ3,5x13 mm	14x p51 φ3,5x15 mm	6x w4 310 mm
-------------------------	----------	--------	---------	---------	-----------------------	---------------------	----------	-----------------------	------------------------	------------------



Assemble the unit as shown in the pictures using indicated connectors and/or joints.

2 Wardrobe 2d3s

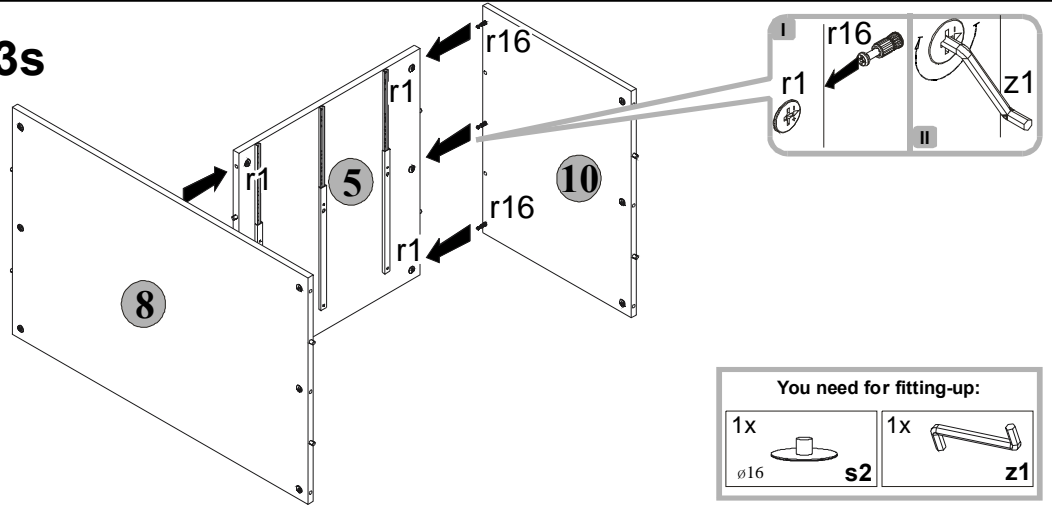

3 Wardrobe 2d3s

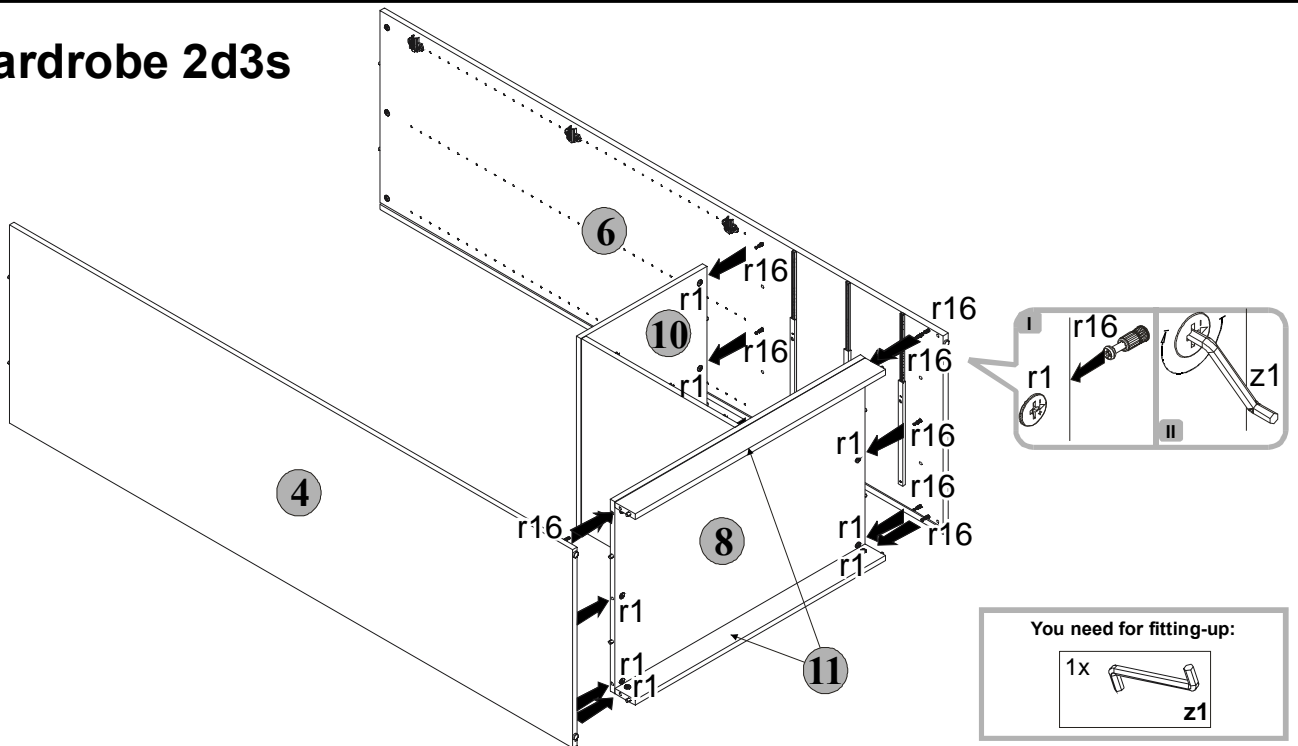

4 Wardrobe 2d3s

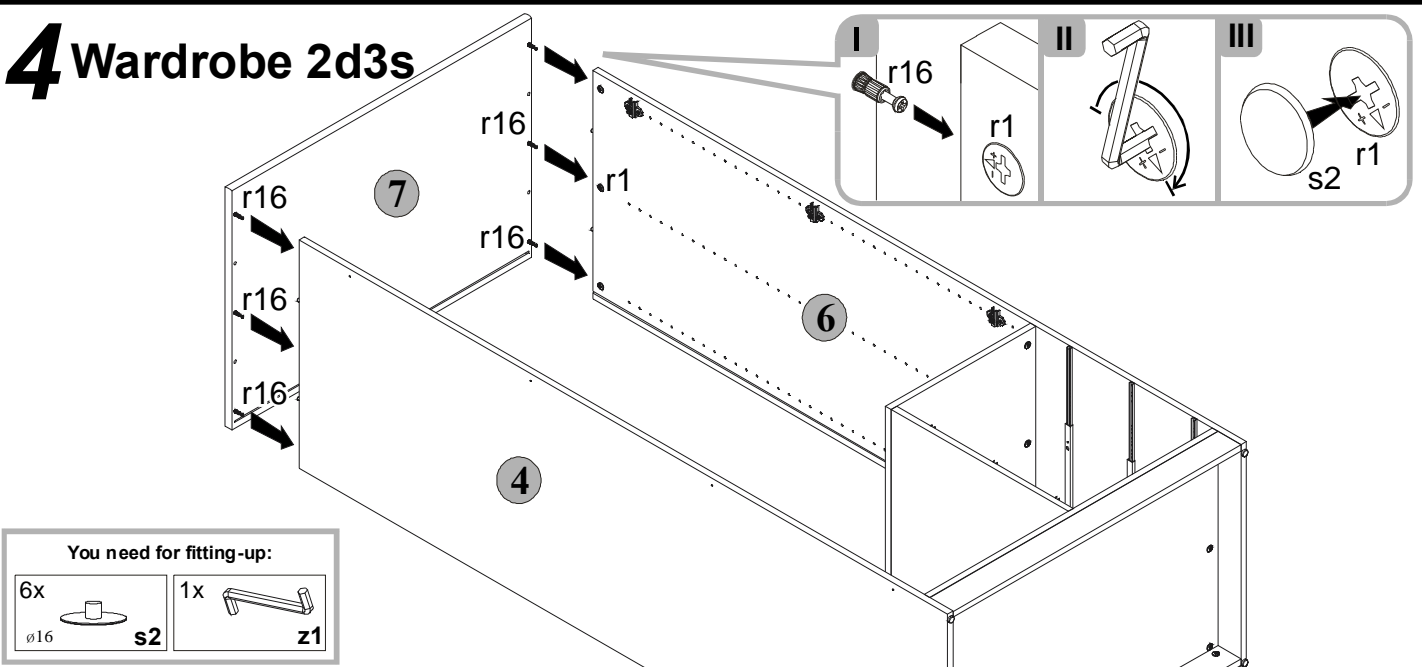

5 Wardrobe 2d3s

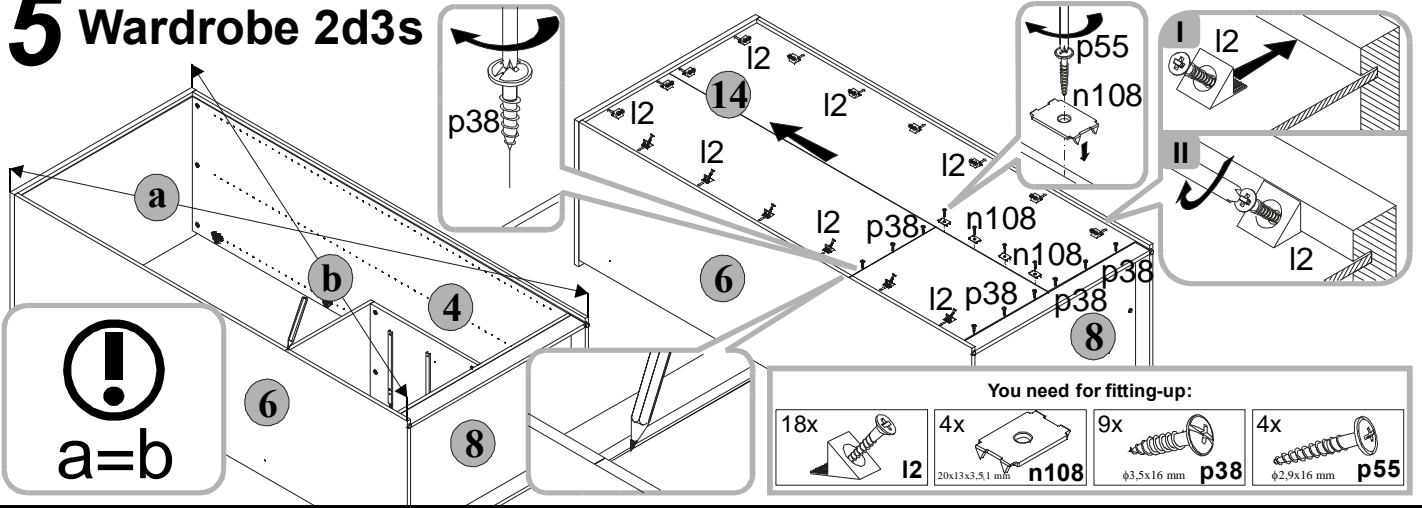

6 Wardrobe 2d3s

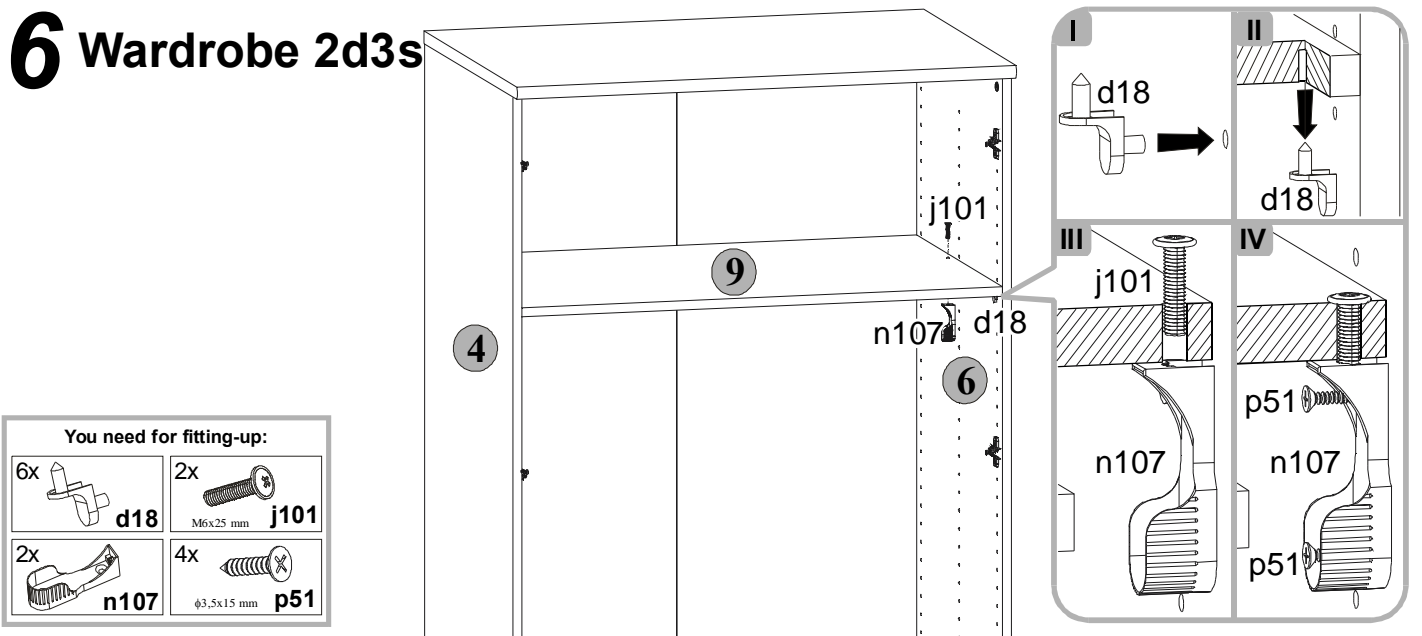

7 Wardrobe 2d3s

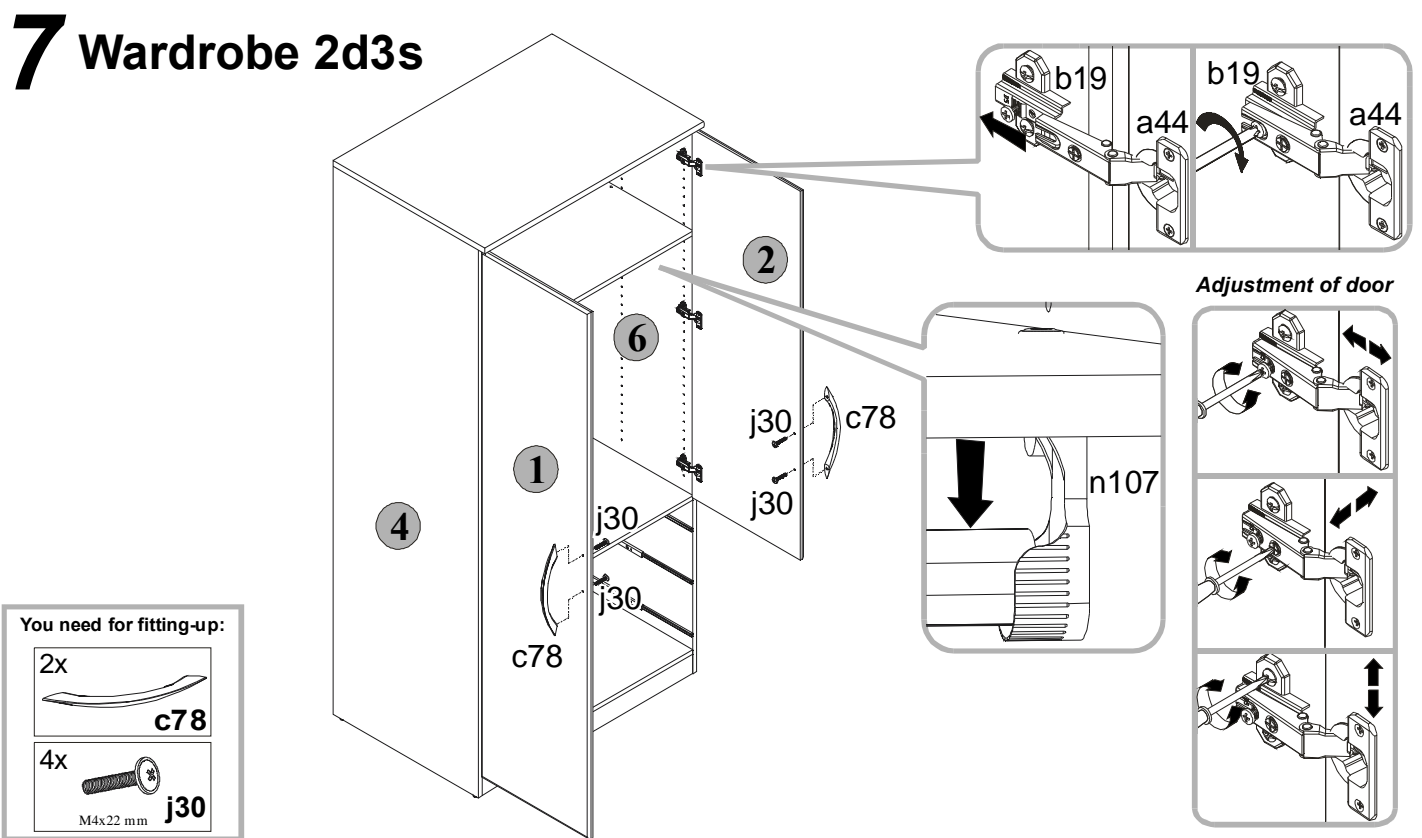

8 Wardrobe 2d3s



Attention: The assembly of the drawer should be done very carefully in order to avoid damaging the delicate joints of the drawer band.



Place **y1** glue in the holes in the component shown, mount the component and leave while the glue dries.

I

You need for fitting-up:

- 12x $\phi 8 \times 30$ mm **f1**
- 1x **y1**

II

You need for fitting-up:

- 1x **y1**

III

IV

You need for fitting-up:

- 3x **c78**
- 6x M4x22 mm **j30**
- 1x **y1**

9 Wardrobe 2d3s

You need for fitting-up:

- 6x M4x9 mm **j2**